



Fairview Developmental Center Specific Plan Outreach Summary

Workshop 2 Details

The City of Costa Mesa hosted the second round of community engagement for the Fairview Developmental Center Specific Plan. The city hosted three (3) separate workshops, in English and Spanish.

- **English** – Tuesday, January 23, 2024
 - 6 p.m. to 8 p.m.
 - Costa Mesa Senior Center, 695 W 19th St., Costa Mesa
 - **87** Attendees
 - **37** comments cards submitted.
- **Spanish** – Thursday, January 25, 2024
 - 6 p.m. to 8 p.m.
 - Costa Mesa Senior Center, 695 W 19th St., Costa Mesa
 - **9** Attendees
 - **2** comments cards submitted.
- **English and Spanish** – Monday, January 29, 2024
 - 6 p.m. to 8 p.m.
 - Hosted virtually using Zoom.
 - **33** Attendees

Workshop Advertisement

The city advertised the workshop through the following media and print forms:

- Workshop flyer mailed to all residential household in Costa Mesa (45,000 addresses).
- Email sent to everyone on the FDC interest list announcing the availability of the guiding principles and draft vision statement on the website and inviting them to Workshop #2.
- City Manager Weekly Snapshot featured the workshops twice.
- E-notification sent to various city email lists.
- Email sent to more than 70 community group contacts (churches, schools, daycare, afterschool, larger apartment complexes).
- Workshop flyer posted on Nextdoor (45,000 subscribers).
- Workshop flyer posted on the City's social media accounts.
- Workshop advertisements on CMTV between show carousel, city council pre and during meeting carousel, City Hall Concierge monitor carousel.
- Workshops announced at the January City Council meetings.
- Flyers shared at city department meetings/events.
- Flyers regarding the workshop distributed to various city facilities, county library, and supermarkets and businesses.



- Workshop flyer featured in City partner social media and/or member email (Chamber of Commerce).

Workshop Outline and Purpose

The goal of the second set of workshops was to gather community feedback on the draft Vision and Guiding Principles as well as feedback on preliminary circulation and open space concepts. In addition, the workshops provided a project summary and recap of input received at the first round of workshops. The in-person workshops provided time for an individual survey; however, to best facilitate feedback collection in a virtual setting, the third workshops utilized breakout groups. The format of the three workshops was otherwise consistent and included the following information and activities:

- Welcome and team introductions.
- A presentation to provide project background and context, a summary of Workshop 1 feedback, and project timeline.
- Time for live Q&A regarding the project.
- A presentation on the draft Vision and Guiding Principles
- Group discussion for community comments and feedback.
- A presentation on the draft Circulation and Open Space Concepts.
- Opportunity for attendees to prioritize the Concepts.
 - Provided through a survey in person.
 - Done in breakout rooms virtually followed by a report out from each group.
- Presentation from Brian Ferguson at CalOES regarding the Emergency Operations Center. He confirmed that CalEOS had removed the helipad from the plans for the EOC.

Complete recordings of the Spanish and English Presentations provided at the virtual workshop are available on the project webpage at **FDCHousingPlan.com**. Copies of the PowerPoint presentations are also posted on the webpage. All written ideas from the group exercises and a summary of comments are included in this document.

Workshop Photos

These photos are from the in-person workshops held on January 23 and January 25.

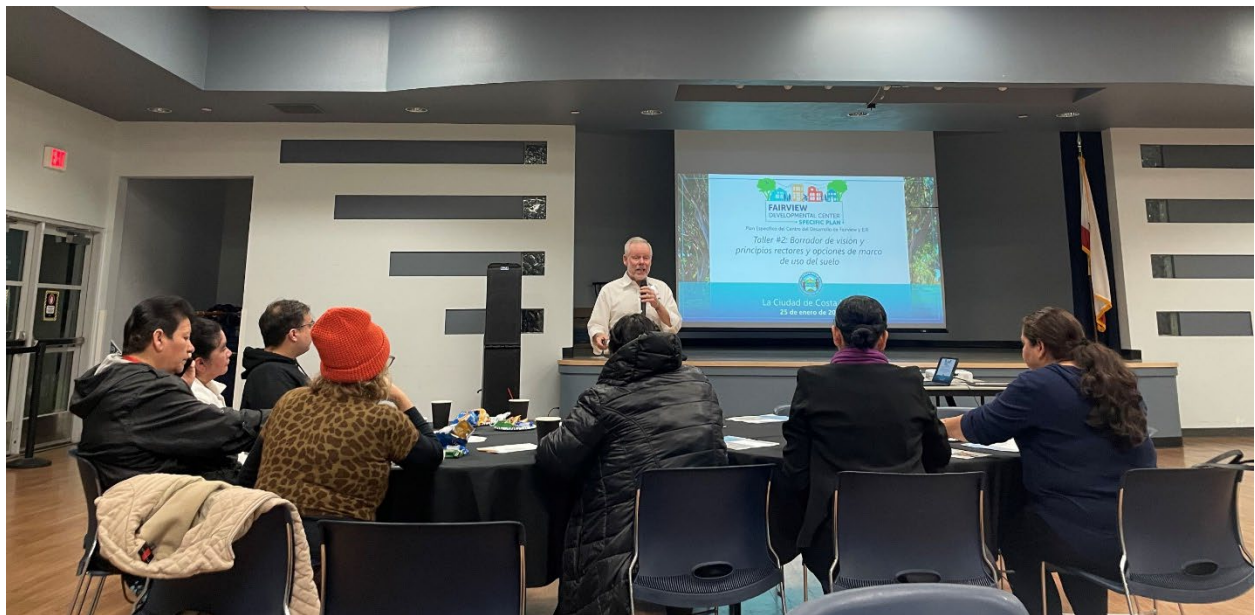



Vision and Guiding Principles Feedback

Following the presentation of the draft Vision and Guiding Principles, the community was asked to consider the following questions:

- What stood out to you?
- Does something need clarifying?
- Would you add or take away anything?

A summary of comments and discussion from all participants is outlined below. Additionally, scans of live notes taken at the in-person workshops are included.

Summary of Feedback on the Draft Visions

- Key words should be defined or clarified, including:
 - One-of-a-kind
 - Diverse
 - Unique
 - Sustainability
 - Variety of housing
 - Quality design
- Open space and recreation should be emphasized.
- A statement or language that prioritizes housing for existing Costa Mesa residents should be included.
- Community centers and services for future residents should be included.
- A focus on housing at all incomes, and defining the various income levels, should be a priority for the vision.
- Consideration of a new location for the Emergency Operation Center (EOC) was mentioned, as well as concerns about access and traffic related to the EOC.
- It's important to identify how quality design and materials will be incorporated into the plan, particularly regarding sustainable buildings and sustainable practices.
- The value and importance of a resident's ability to age in place was noted.

Vision Comments – Tuesday, January 23rd

- Define residents who are moving in/ need homes for children who want to stay in the area as they grow vision 1/23
- residents – prioritize current residents
- Define one on a kind living environment
- Transportation / BUS
- vision should focus on other priorities (all) from Workshop #1 (see pp chart)
- Special needs – units
- Ownership & Rental?
- Safety – For all of the City
- clean up Costa Mesa
- sustainable
- environmental concerns
- reduce reliance on autos – ? How
- parking (Guiding Principles)
- How to define people of All backgrounds
- Future tense is confusing
- Difficult to read ~~read~~
- Define Quality Design
- parking & staging for spots Framework 1/23
- Housing Affordability / questions parking on
↳ in come levels

- Can there / should there be additional access points? Frame table 1/23 criteria
- what will happen to home values?
- How will this impact taxes?
- extension of Shelly Lane
- Balance parks
 - Baseball & soccer fields
- Who will Maintain Open space
 - what is the area serving? Guiding Principles 1/23
who? current residents / all of Orange County
 - what does sustainability mean
 - sustainability – cars
 - Plan & vision cannot conflict
 - Value of property / Housing along the golf course
 - Vision like corp. Mission statement Vision 1/23
Property for future purpose – clarity
what is the best use
- What is a neighbor hood? Guiding Principles 1/23
- Make less sales pitch
- Come back with more project facts & next steps
- what do affordable units look like & how are they integrated?
- from community on what is already here & loved in Costa Mesa

Vision Comments – Thursday, January 25th

- buen plan Vision para que familias tengan una vivienda digna
 - mas vivienda asequible para ingreso bajas
 - ↳ Incrementar la % para que viviendas de bajos ingreso sea la mayoria
 - priorizar accessibilidad
 - hacer las amenidades publicas
 - Oportunidades para persona indocumentadas
 - apoyan el desarrollo sostenible
 - Sendero cercano
 - ↳ priorizar la camnabilidad
 - amplia gama de niveles de ingreso
 - alvercas comunitarias / Centro comunitario
 - ↳ arens para bailar
 - oportunidades para comprar
 - ↳ mejorar la calidad de vida
 - ↳ precios de comprar sean asequibles
 - community land trusts
 - ↳ manejado para de parte de una organizacion sin lucro ota ciudad
 - ↳ cambiar los requisitos para aplicar para la vivienda
 - incluyen las vision generaciones presentes
 - ↳ prevenir el desplazamiento
 - ↳ preservar la comunidad existente
 - ↳ oportunidades para comprar
 - mezclar las unidades de varias ingreso (ejemplo, bajo, moderado y otras)
 - priorizar los trabajos de construccion sean de Costa residentes Mesa
- 90% Brady fo go (vision completion)

principios rectores

- jardin comunitario
 - ↳ clases / programas
 - ↳ nopales
- Centro comunitario
 - ↳ ideas para mejorar la comunidad
- estaciones de autobus cercanas y convenientes
- Organizaciones que cuidan el medio ambiente
- plaza central entre los edificios
 - ↳ quiosko / kiosk
- albercas comunitario
- gimnasio comunitario
 - ↳ estaciones de ejercicio

circulacion

- Camino circular
 - ↳ no les gusta
 - ↳ se sienten como encierran la comunidad
- Bulevar
 - ↳ no es seguro para los peatones / niño
- Sistema de red
 - ↳ favorecida de la mayoria

Espacios Abiertos

- combinacion
 - ↳ mas cercana
 - ↳ personas de tercer de edad pueden caminar mas facil si estan cercanos

- Out reach methods (Suggested)
- ↳ Flyers
 - ↳ door knocking
 - ↳ collaborate w/ schools
 - ↳ churches
 - ↳ english learning classes
 - ↳ Costa mesa high



Circulation and Open Space Feedback

The second workshop activity presented initial circulation and open space concepts. Following the description and presentation of the concepts, attendees were asked to provide feedback through either a survey (in-person workshops) or in a discussion group (virtual workshop)

Summaries of the input received are below.

Individual Activity

During the English and Spanish in-person workshops, a preference questionnaire was provided to participants in either a paper format or through Mentimeter (an online polling tool). The activity gathered preference on open space amenities, alternative mobility options, and preference of circulation and open space concepts. Overall, participants had a wide range of interests regarding open space amenities with a focus on trails, a recreation center and playgrounds – a few participants also noted pickleball courts, in addition to the options listed. Regarding alternative mobility options, walking and biking were noted as most common and popular, followed by golf carts/NEV.

Below are the results for all responses.

Question 1: For active open space areas, what types of facilities do you prefer?

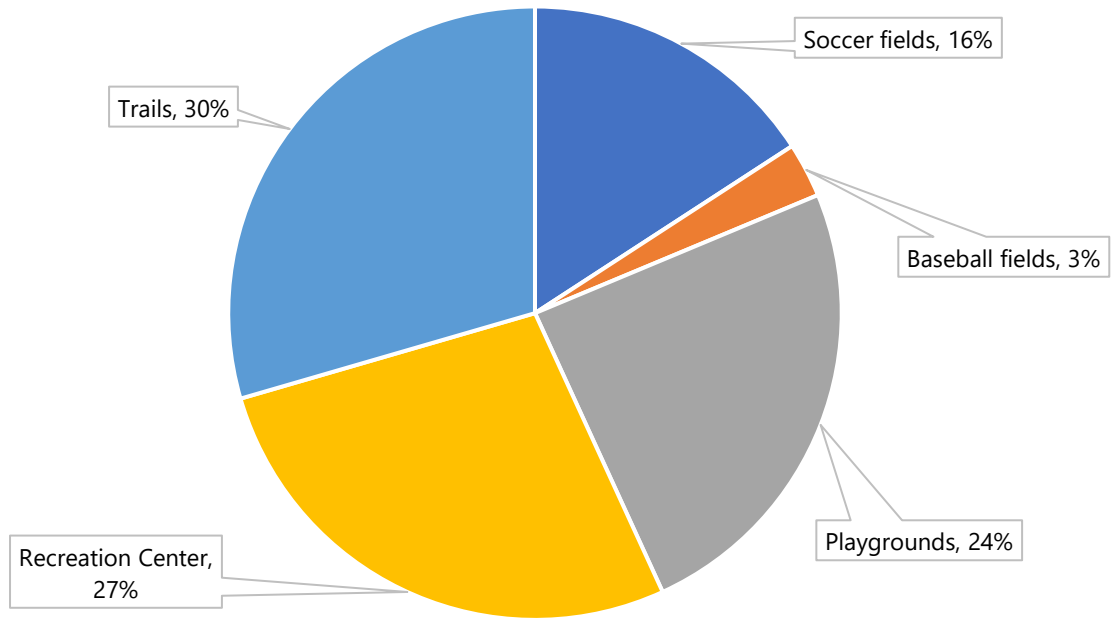

Question 2: What alternative modes of transportation do you prefer?

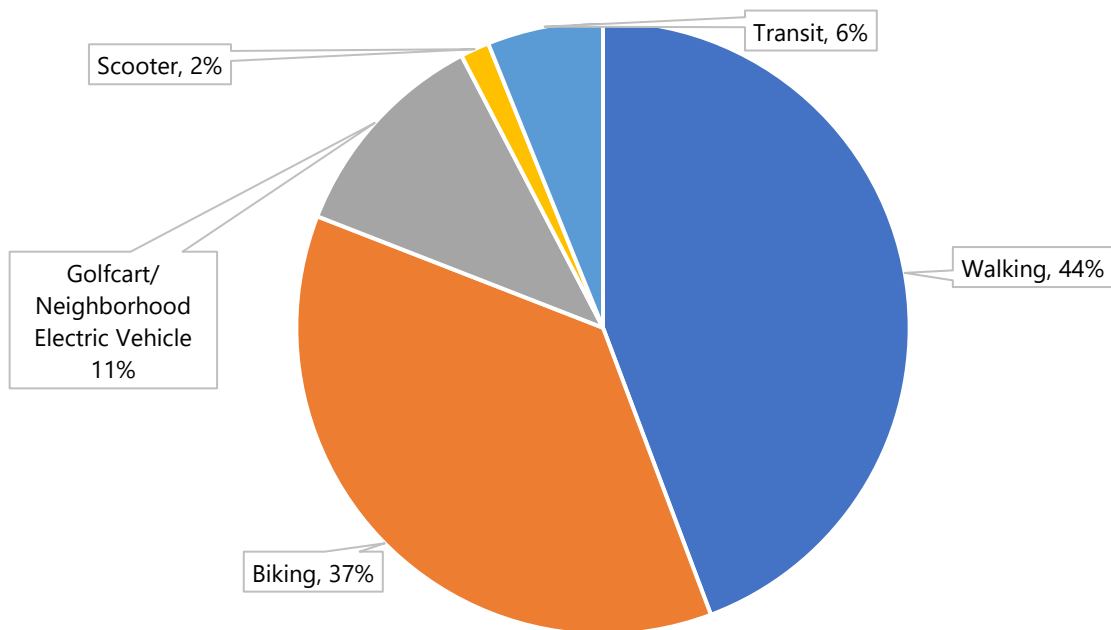

Question 3: Of the three images, which circulation concept do you prefer?

Concept 1 - Loop

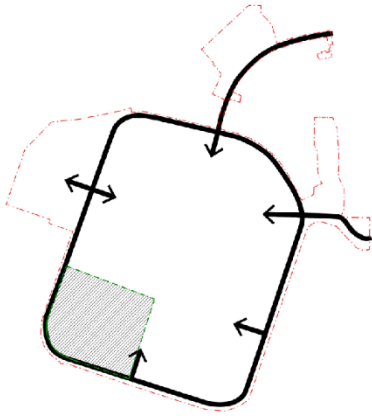

Concept 2 - Boulevard

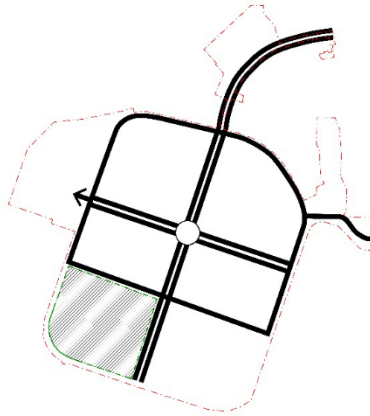

Concept 3 - Grid

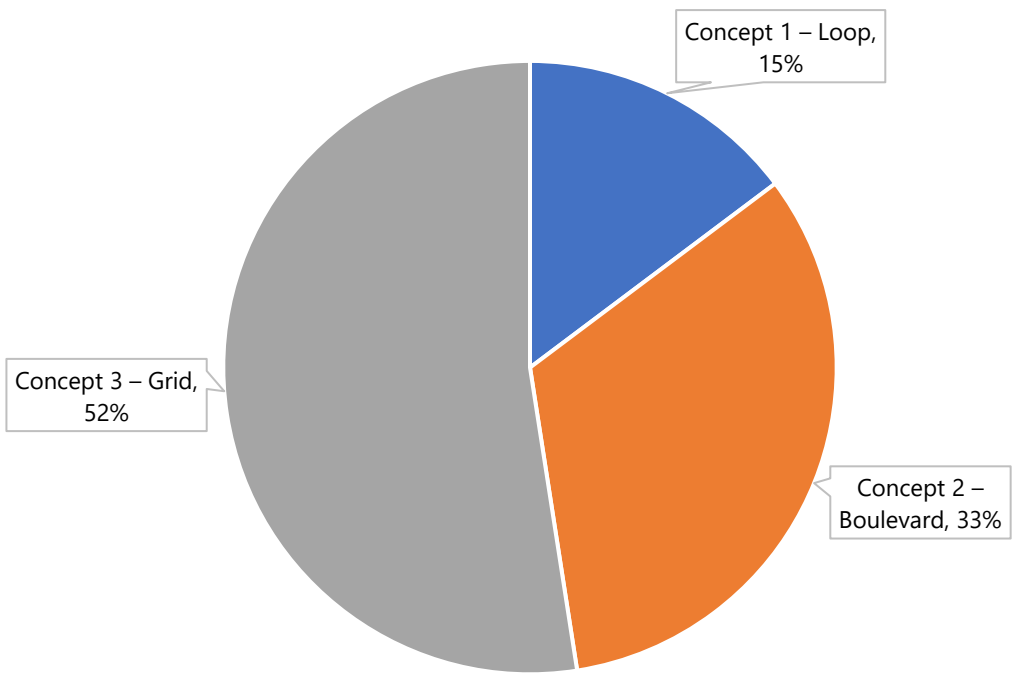
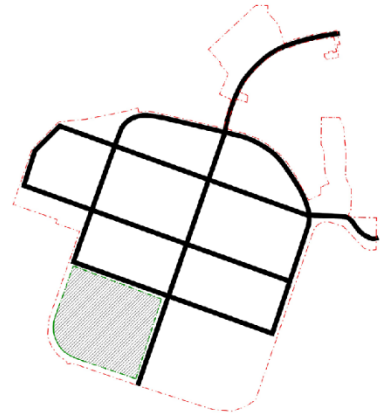

Question 4: Of the three images, which park/open space configuration do you prefer?

Concept 1 - Consolidated

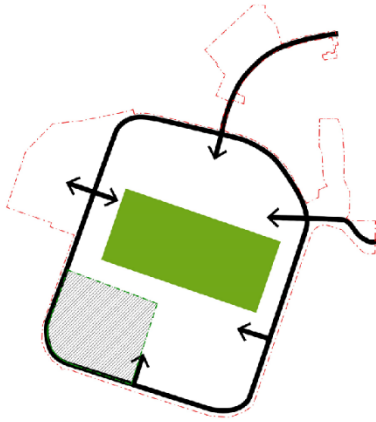

Concept 2 - Distributed

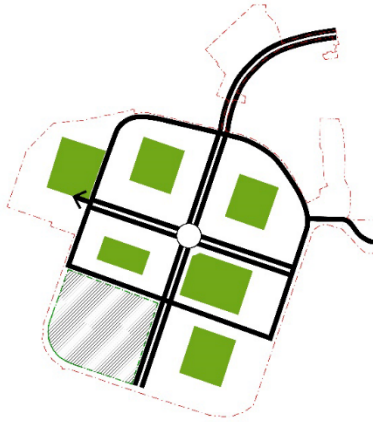

Concept 3 - Combination

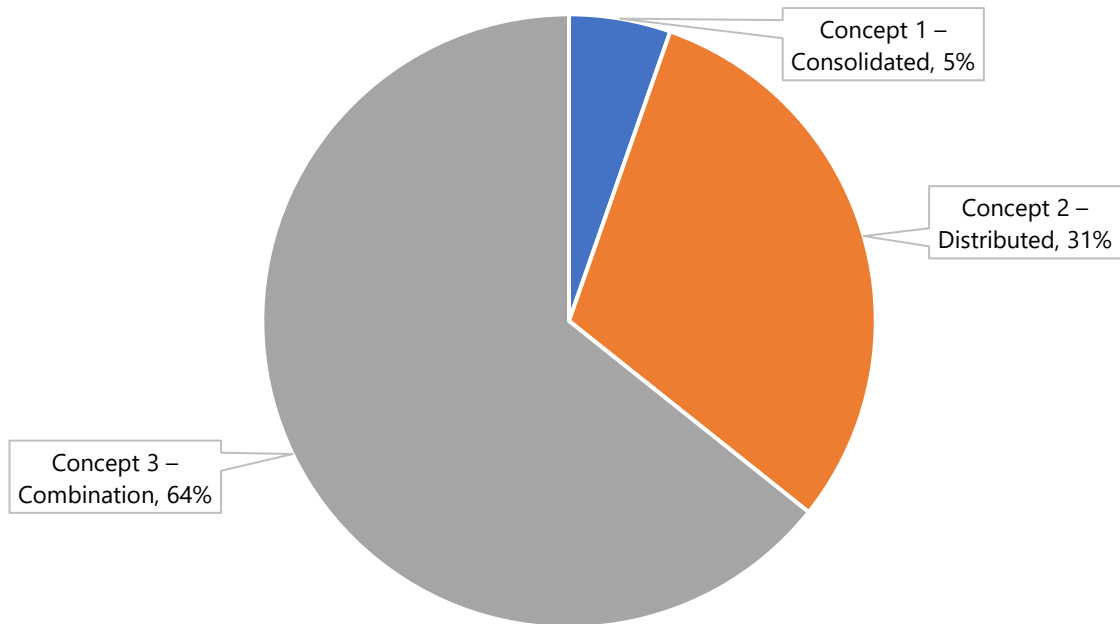
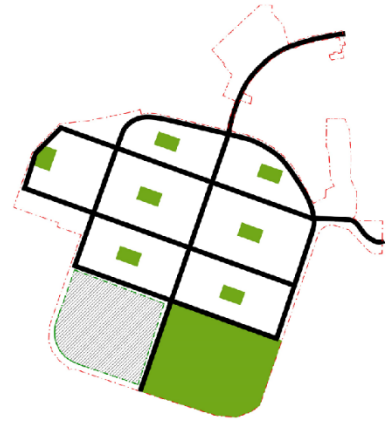



Breakout Groups

During the virtual workshop, participants were assigned to breakout groups of 3-5 people to discuss the land use concepts. To gather feedback on the concepts the groups were asked the following questions:

- What do you like?
- What would you add/change?
- What combination of Open Space and Circulation Framework options would you put together?

Once the breakout rooms closed, each group leader gave a summary report of the discussion and feedback received. Overall, many participants noted that maintaining low traffic speeds and reducing vehicle use was a priority for circulation. Participants also noted that walkability, safety for cyclists and proximity to open space were of high importance in the concept designs. Most participants felt that Option 3 Grid and Combination were the best options, creating more walkable streets, and access to recreation and a neighborhood feel or experience.

Additionally, images of the whiteboard from each group are included below.

Breakout Group Discussion Scans

Concept 1 – Loop/Consolidated

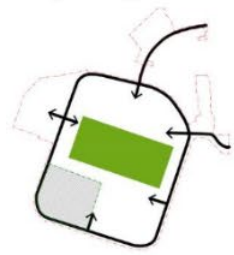

Priyanka Agarwal

EOC Location:
Located closer to harbor
blvd / entrance
Ideas are contingent on
EOC location and size.
How will it work, what are
the housing options?

Concept 2 – Boulevard/Distributed



Priyanka Agarwal

Combination of
distributed and third
option, more green
where they are living.
Make green space
usable and builds
community.

Concept 3 – Grid/Combination



Priyanka Agarwal

Mixed use, retail,
grocery

What do you like?
What would you add/change?
What combination of Open Space and Circulation
Framework options would you put together?

Priyanka Agarwal

Don't like the central
park idea

Priyanka Agarwal

Central green may
not work, may limit
housing construction
opportunity. Rather
have green closer to
where they live.

Priyanka Agarwal

Don't like the big
boulevard, hurts the
walking/biking
opportunities. Could
work or not.

Priyanka Agarwal

Additional access
points for biking and
walking aside from
car

Surrounded by golf
course, easy to put
biking and walking
path. Access to
Plecentia is a concern
with golf course.

Priyanka Agarwal

Get cars off the road.
Future EV network,
transportation, build
infrastructure into
parking lots.

Priyanka Agarwal

Electric shuttle
buses that connect
to Harbor

Thomas Ventura
consider reusing existing soccer fields

Thomas Ventura
want to see walk streets included

Concept 1 – Loop/Consolidated

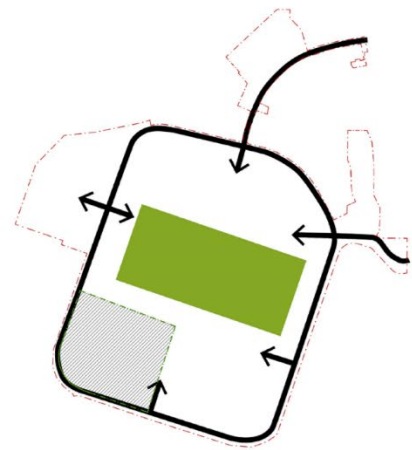

Concept 2 – Boulevard/Distributed

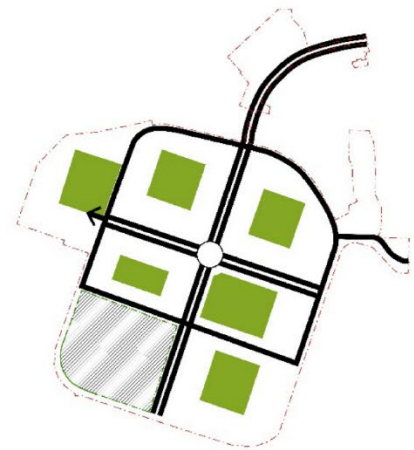

Concept 3 – Grid/Combination

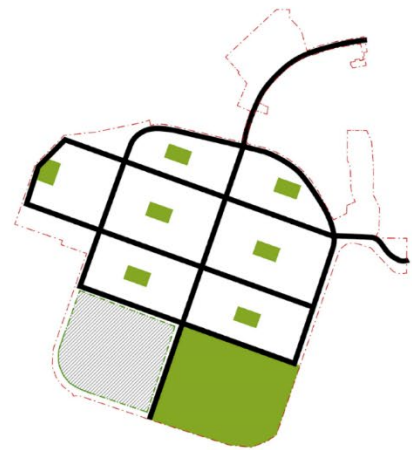

Thomas Ventura
consolidated greenspace is preferred - both loop and grid ideas could work

Thomas Ventura
large double lane roadways may not be conducive to neighborhood setting

Thomas Ventura
dedicated bike lanes needed to reduce stress on cyclists

Thomas Ventura
central roundabout is concerning

Thomas Ventura
larger green space devoted to sports with pocket parks

Thomas Ventura
possible track around greenspace

What do you like?
What would you add/change?
What combination of Open Space and Circulation Framework options would you put together?

Concept 1 – Loop/Consolidated

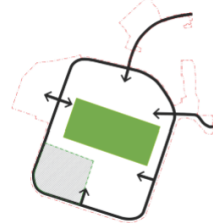

Karen Gulley, Moly Mendoza
Loop system could be hard to get around, but can more dense (Irvine)

Karen Gulley, Moly Mendoza
Based on usability of space, either concept 1 or 2,

Concept 2 – Boulevard/Distributed



Karen Gulley
Joann trail could feed into area. Walk without being hit.

Concept 3 – Grid/Combination



Karen Gulley
Tustin Legacy ex: did more of a grid. Seems to work, but alot of road that could be used for other uses.

What do you like? What would you add/change?

What combination of Open Space and Circulation Framework options would you put together?

Concept 1 – Loop/Consolidated

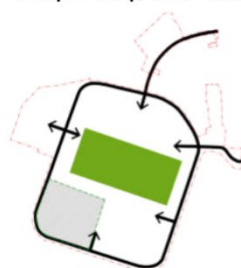

Concept 2 – Boulevard/Distributed



Concept 3 – Grid/Combination



Suzanne Schwab
Doesn't like big open space- no amphitheater-likes Boulevard.
Big events cause noise and traffic.

Suzanne Schwab
Maybe the consolidated green space could be more central.

Suzanne Schwab
Loop structure isn't accessible enough for other modes of travel- other than cars.

Suzanne Schwab
Blvd. Might encourage high speed driving but likes green space.
Don't want Harbor Blvd here. Design to maximize safety.

Suzanne Schwab
I like combination. Consolidated doesn't make green space equitably accessible enough. Everyone deserves to have a nearby green space and the benefits they provide such as for mental health and lowering community temperatures

Suzanne Schwab
A well designed consolidated green space brings the community together...well placed walkways, bike trails, ...most complexes are so broken up resulting in patches of green space that end up being green cement

Suzanne Schwab
If distributed green space, still grid (no blvd)

Suzanne Schwab
Grid more walkable and seems safer for all users.



Summary of Comments

The table below includes a summary of all comment cards submitted to the project team during the second rounds of workshops.

Category A – Adjustments to the draft Vision	Category B – Complete revision of the draft Vision	Group C – Other project related comments
<p>Count: 17 comments</p> <p><i>Summary of Comments:</i> Overall comments focus on specificity, encouraging the vision and/or guiding principles to nail down definitions and provide examples. Most comments provided ideas or features desired.</p>	<p>Count: 6 comments</p> <p><i>Summary of Comments:</i> Overall comments focus on changing the vision entirely because the commenter did not like what was provided.</p>	<p>Count: 15 comments</p> <p><i>Summary of Comments:</i> Overall comments focus on the EOC, access and traffic and availability or sufficiency of infrastructure.</p>
<ul style="list-style-type: none"> • Include very low income in the housing principle. • Get more specific with types of open space and rec amenities. • Be more specific on sustainable features. • More discussion on walking paths, mobility features and parking, schools and public amenities/services • Define “buzzwords”. • Use bullets for the guiding principles so it’s clearer. • Review Culdesac, Arizona and consider defining “all types of housing”. • Focus on the open space. • Examples/case studies might be helpful to show the community. 	<ul style="list-style-type: none"> • Should be more specific, sounds too much like a pitch and not a vision. • Principles are too general. • Feels one dimensional. • Doesn’t feel serious – no automobiles are the only way to achieve a lot of what is said in the vision, and that isn’t possible. • I don’t trust this process and don’t think input was considered in the vision. • The vision statement is “garbage” – look at Freedom Homes mission statement and use that as a starting point. • Reduce reliance on automobiles is naive, we live in Freedom Homes and 	<ul style="list-style-type: none"> • Find a way to control the “hate” and “clean up costa mesa” comments. • Can we prioritize existing CM residents when units are available? • Ensure no entities can “flip” properties and inflate rents/sales. • The EOC should be on Harbor. • Consider what artifacts might be on the site. • There is not enough access in the event of an emergency. • How will this project be supported from an infrastructure standpoint? Is there enough water? • More mailers/social media posts and other advertisement to get the word out about these meetings.



<ul style="list-style-type: none"> • Use Costa Mesa Specific vernacular – get specific on goals in the guiding principles. • Focus of local retail, discuss shared spaces that facilitate community, there are lot of young families in Costa Mesa • Basketball courts • Please don't let this be a Rancho Mission Viejo or Irvine type of development. • Consider providing the information in a clearer way, there was so much to digest that it is hard to provide feedback. • Discuss safety/visibility. • Prioritize impacts to current residents. • Community gardens • Community supportive features (schools, health centers) should be included in the vision. • Find ways for the amenities to subsidize and fields/supportive features. • More youth fields. 	<p>that should be the model for this vision.</p>	<ul style="list-style-type: none"> • These meetings should be shared with the County and state – it feels like we are forced into something we (residents) don't want. • Traffic is already very bad and high density will make it worse. • There are water supply issues. • Will there be veteran housing? • The meeting was hard to access, held away from the main entrance of the building and there was no entrance closest to the meeting room. • I hope other residents understood the purpose of the meeting. • I wish I knew about the first meeting. • Support seniors • Consider a 4th option for open space – one large park with sports fields, and one large park for a rec center in another area. • You can't expect 5,000 cars to go in/out on Harbor during rush hour. • Add senior housing, is infrastructure sufficient, traffic on harbor is already bad. • FDC should be used for Industrial not more housing. • I prefer loop and distribute Open space is better.
--	--	---



Appendix A: Preference Questionnaire Scans

The following section includes scans of every survey collected at the Tuesday January 23rd and Thursday January 25th in-person workshops.

¡Cuéntanos más sobre ti! ¿Cuál es tu afiliación con Costa Mesa?

- Soy residente
- Soy de una ONG/Sin Fines de Lucro
- Soy propietario de un negocio
- Soy promotor
- Soy propietario
- Otros

Para las zonas de espacios abiertos activos, ¿qué tipos de instalaciones prefieres? (Elige 2)

- Campos de fútbol
- Campos de béisbol
- Parques infantiles
- Centro recreativo
- Senderos

¿Qué medios de transporte alternativos prefieres? (Elige 2)

- Caminar
- Bicicleta
- Carro de golf (o Vehículo Eléctrico Vecinal)
- Scooter
- Tránsito

De las tres imágenes, ¿qué concepto de circulación prefieres? (Elige 1)

Concepto 1 - Bucle

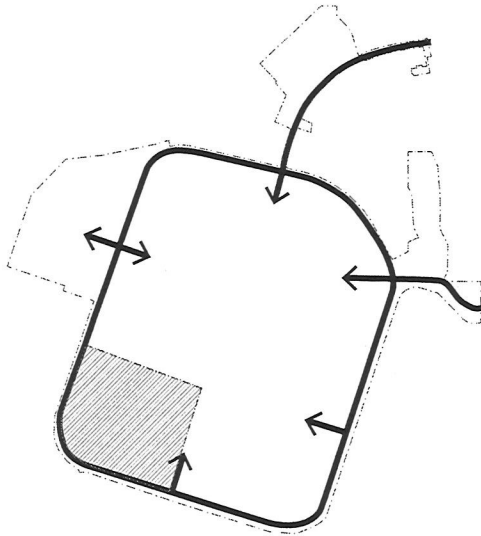

Concepto 2 - Bulevar

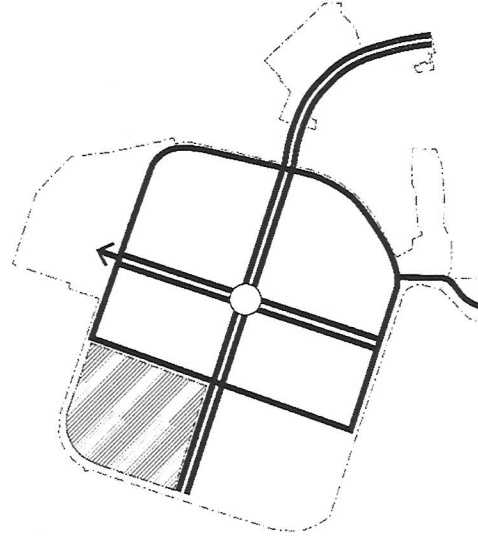

Concepto 3 - Cuadrícula

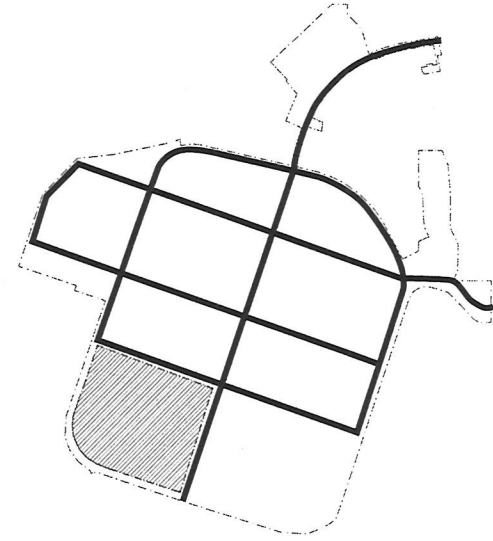

- Concepto 1 - Bucle
- Concepto 2 - Bulevar
- Concepto 3 - Cuadrícula

De las tres imágenes, ¿qué configuración de parque/espacio abierto prefieres? (Elige 1)

Concepto 1- Consolidado

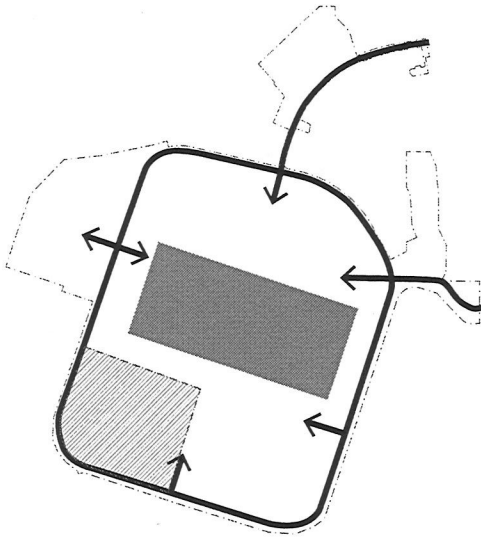

Concepto 2 - Distribuido

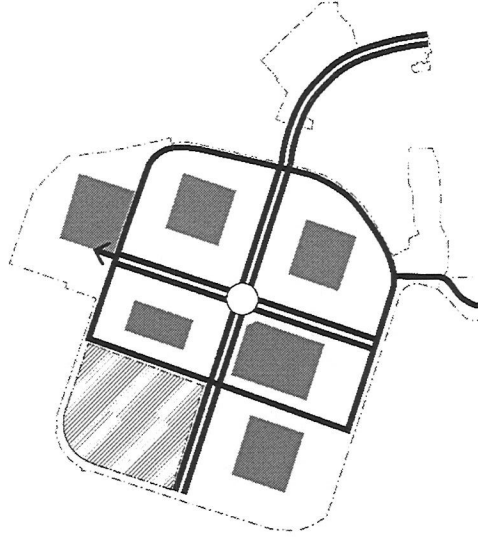

Concepto 3 - Combinación

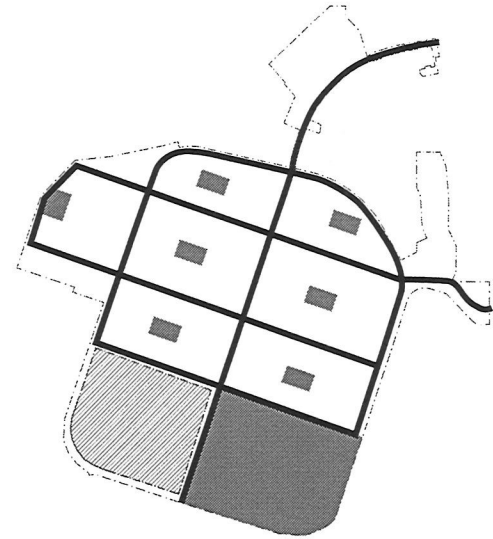

- Concepto 1- Consolidado
- Concepto 2 - Distribuido
- Concepto 3 - Combinación

¡Cuéntanos más sobre ti! ¿Cuál es tu afiliación con Costa Mesa?

- Soy residente
- Soy de una ONG/Sin Fines de Lucro
- Soy propietario de un negocio
- Soy promotor
- Soy propietario
- Otros

Para las zonas de espacios abiertos activos, ¿qué tipos de instalaciones prefieres? (Elige 2)

- Campos de fútbol
- Campos de béisbol
- Parques infantiles
- Centro recreativo
- Senderos

¿Qué medios de transporte alternativos prefieres? (Elige 2)

- Caminar
- Bicicleta
- Carro de golf (o Vehículo Eléctrico Vecinal)
- Scooter
- Tránsito

De las tres imágenes, ¿qué concepto de circulación prefieres? (Elige 1)

Concepto 1 - Bucle

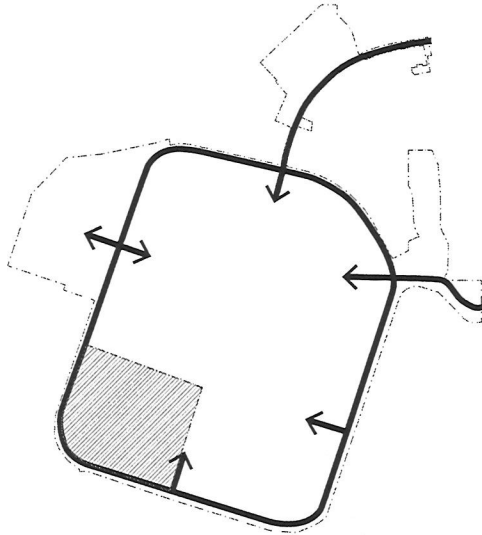

Concepto 2 - Bulevar

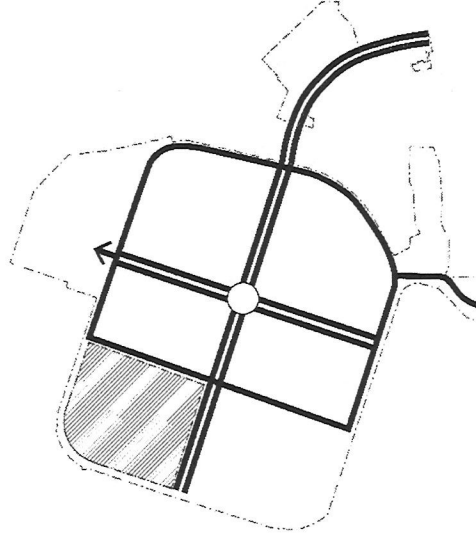

Concepto 3 - Cuadrícula

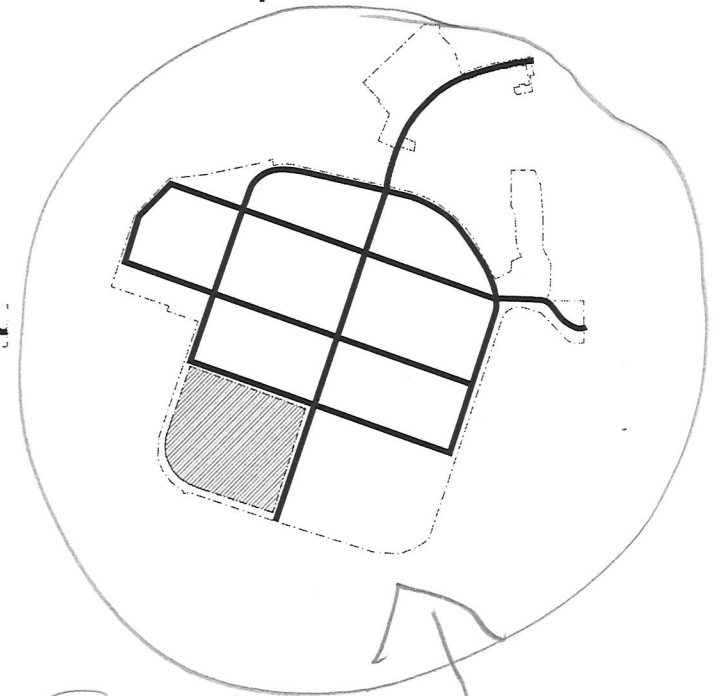

- Concepto 1 - Bucle
- Concepto 2 - Bulevar
- Concepto 3 - Cuadrícula

Este

De las tres imágenes, ¿qué configuración de parque/espacio abierto prefieres? (Elige 1)

Concepto 1- Consolidado

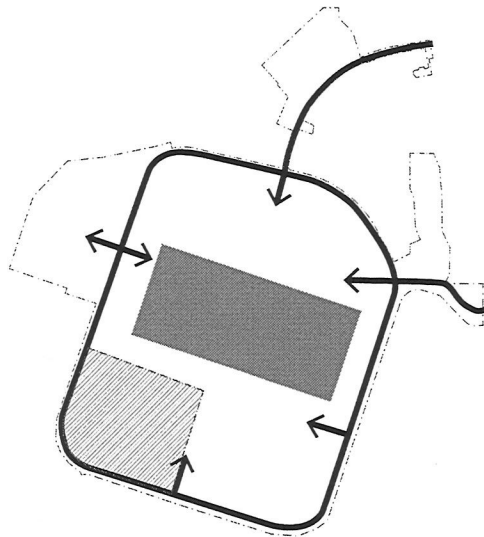

Concepto 2 - Distribuido

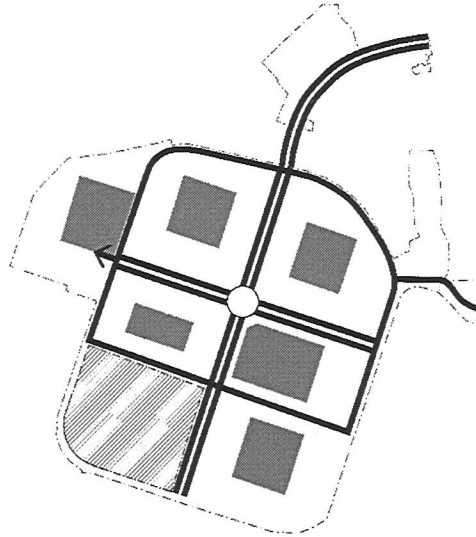

Concepto 3 - Combinación

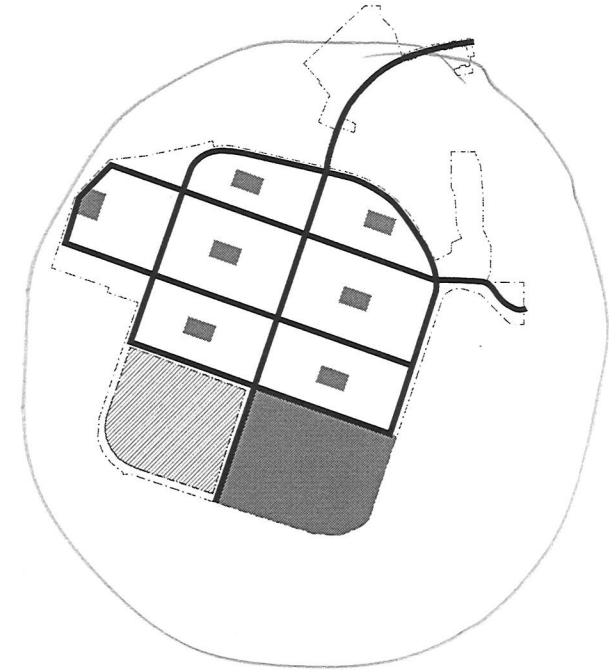

- Concepto 1- Consolidado
- Concepto 2 - Distribuido
- Concepto 3 - Combinación

¡Cuéntanos más sobre ti! ¿Cuál es tu afiliación con Costa Mesa?

- Soy residente
- Soy de una ONG/Sin Fines de Lucro
- Soy propietario de un negocio
- Soy promotor
- Soy propietario
- Otros

Para las zonas de espacios abiertos activos, ¿qué tipos de instalaciones prefieres? (Elige 2)

- Campos de fútbol
- Campos de béisbol
- Parques infantiles
- Centro recreativo
- Senderos

¿Qué medios de transporte alternativos prefieres? (Elige 2)

- Caminar
- Bicicleta
- Carro de golf (o Vehículo Eléctrico Vecinal)
- Scooter
- Tránsito

De las tres imágenes, ¿qué concepto de circulación prefieres? (Elige 1)

Concepto 1 - Bucle

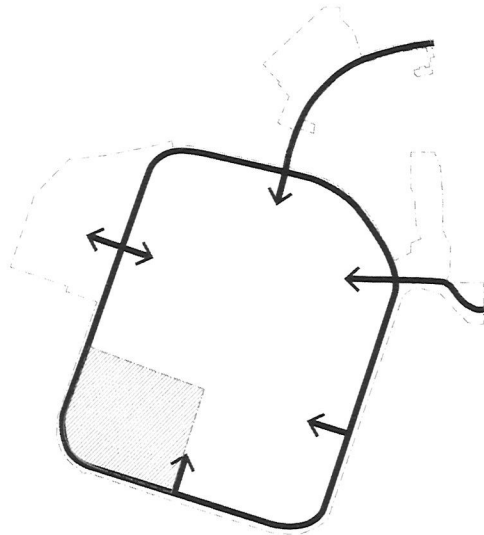

Concepto 2 - Bulevar

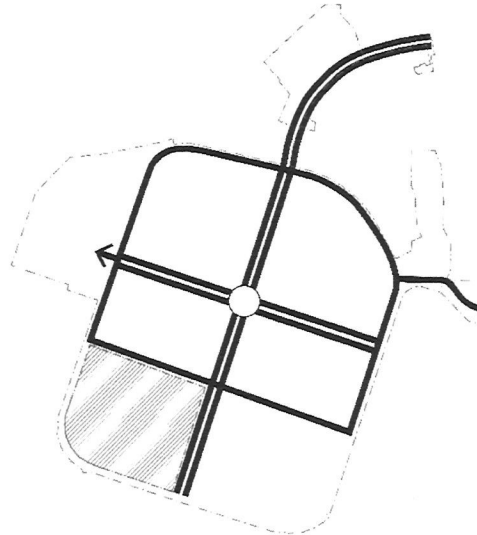

Concepto 3 - Cuadrícula

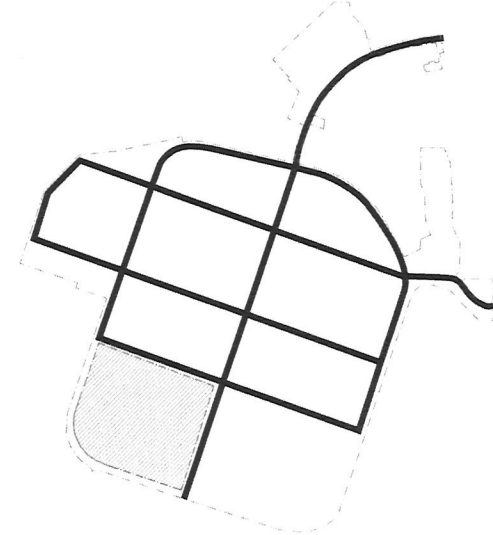

- Concepto 1 - Bucle
- Concepto 2 - Bulevar
- Concepto 3 - Cuadrícula

De las tres imágenes, ¿qué configuración de parque/espacio abierto prefieres? (Elige 1)

Concepto 1 - Consolidado

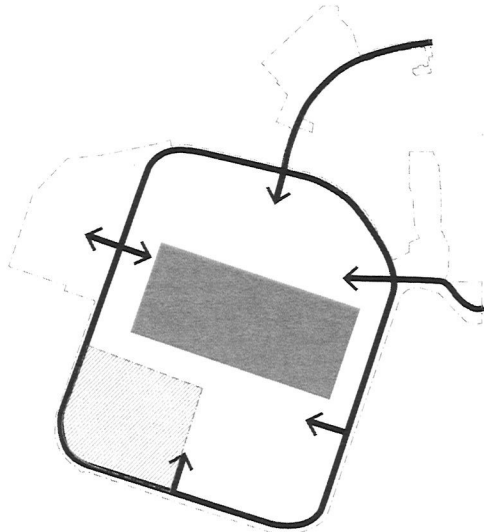

Concepto 2 - Distribuido

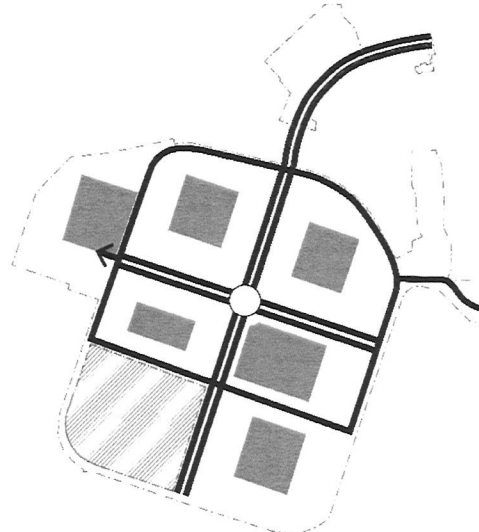

Concepto 3 - Combinación

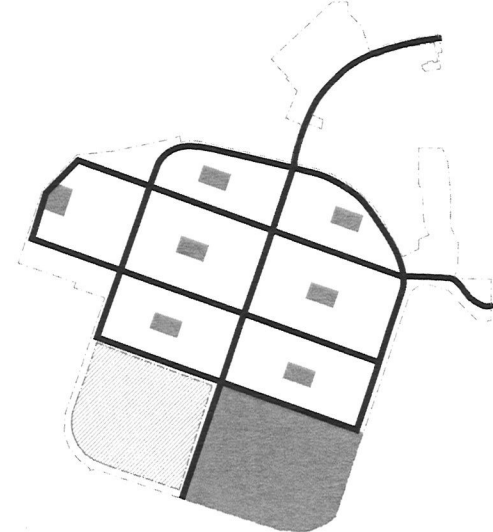

- Concepto 1 - Consolidado
- Concepto 2 - Distribuido
- Concepto 3 - Combinación

¡Cuéntanos más sobre ti! ¿Cuál es tu afiliación con Costa Mesa?

- Soy residente
- Soy de una ONG/Sin Fines de Lucro
- Soy propietario de un negocio
- Soy promotor
- Soy propietario
- Otros

Para las zonas de espacios abiertos activos, ¿qué tipos de instalaciones prefieres? (Elige 2)

- Campos de fútbol
- Campos de béisbol
- Parques infantiles
- Centro recreativo
- Senderos

¿Qué medios de transporte alternativos prefieres? (Elige 2)

- Caminar
- Bicicleta
- Carro de golf (o Vehículo Eléctrico Vecinal)
- Scooter
- Tránsito

De las tres imágenes, ¿qué concepto de circulación prefieres? (Elige 1)

Concepto 1 - Bucle

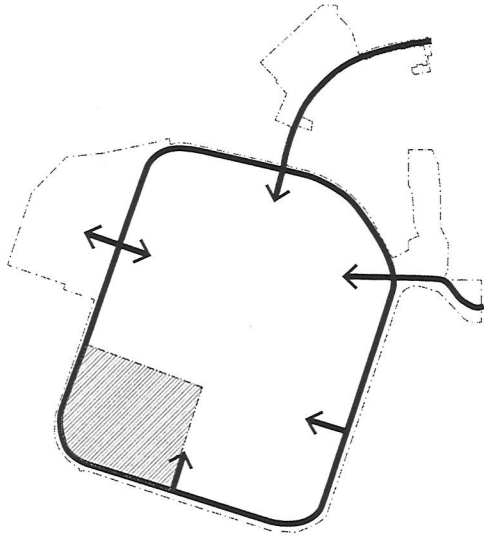

Concepto 2 - Bulevar

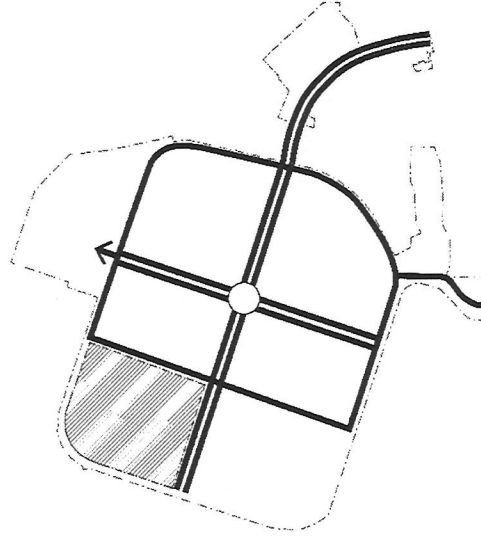

Concepto 3 - Cuadrícula

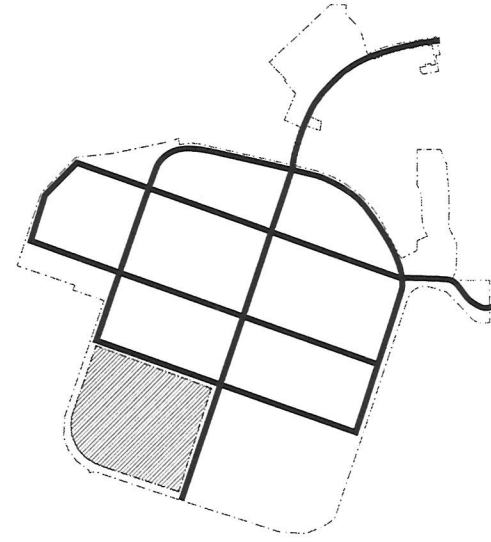

- Concepto 1 - Bucle
- Concepto 2 - Bulevar
- Concepto 3 - Cuadrícula

De las tres imágenes, ¿qué configuración de parque/espacio abierto prefieres? (Elige 1)

Concepto 1 - Consolidado

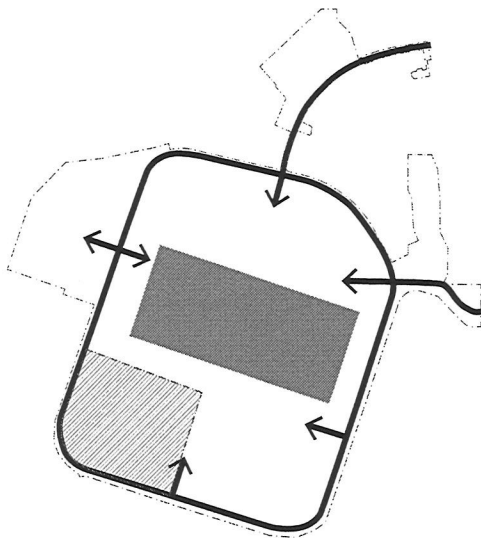

Concepto 2 - Distribuido

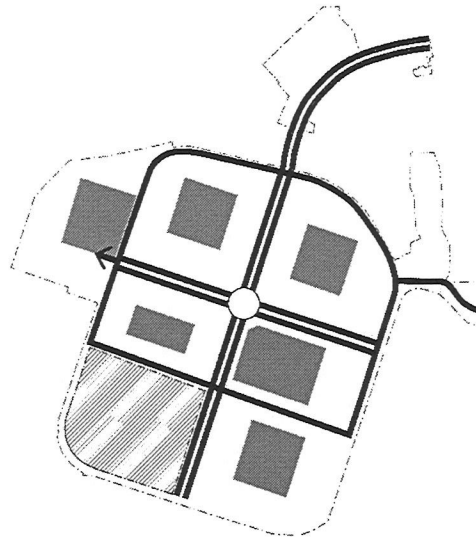

Concepto 3 - Combinación

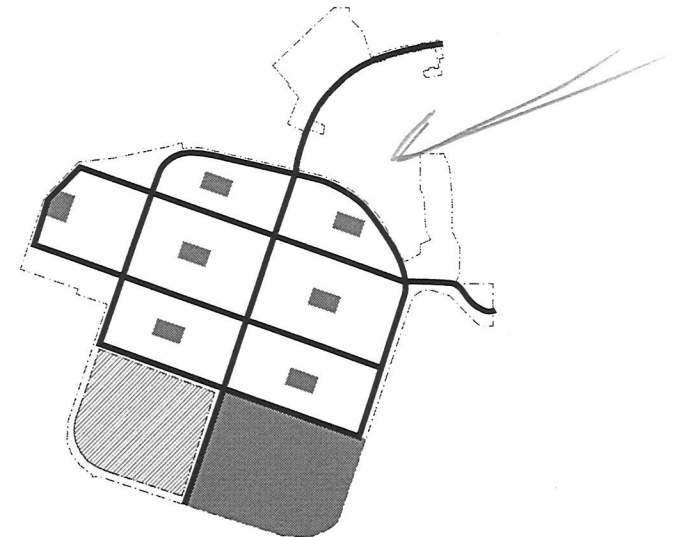

- Concepto 1 - Consolidado
- Concepto 2 - Distribuido
- Concepto 3 - Combinación

¡Cuéntanos más sobre ti! ¿Cuál es tu afiliación con Costa Mesa?

- Soy residente
- Soy de una ONG/Sin Fines de Lucro
- Soy propietario de un negocio
- Soy promotor
- Soy propietario
- Otros

Para las zonas de espacios abiertos activos, ¿qué tipos de instalaciones prefieres? (Elige 2)

- Campos de fútbol
- Campos de béisbol
- Parques infantiles
- Centro recreativo
- Senderos

¿Qué medios de transporte alternativos prefieres? (Elige 2)

- Caminar
- Bicicleta
- Carro de golf (o Vehículo Eléctrico Vecinal)
- Scooter
- Tránsito

De las tres imágenes, ¿qué concepto de circulación prefieres? (Elige 1)

Concepto 1 - Bucle

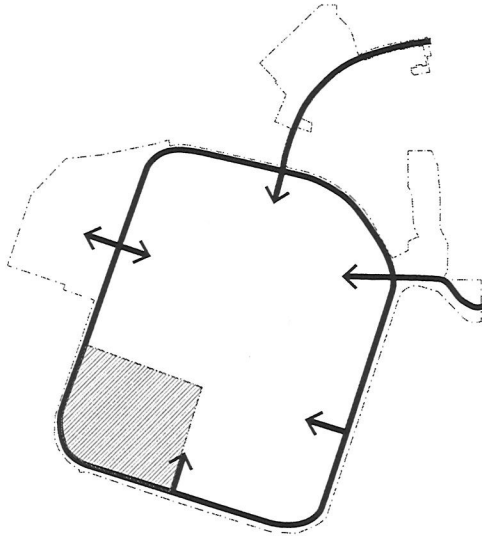

Concepto 2 - Bulevar

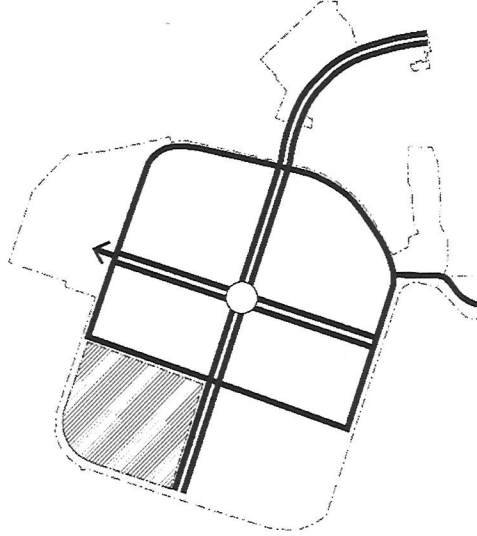

Concepto 3 - Cuadrícula

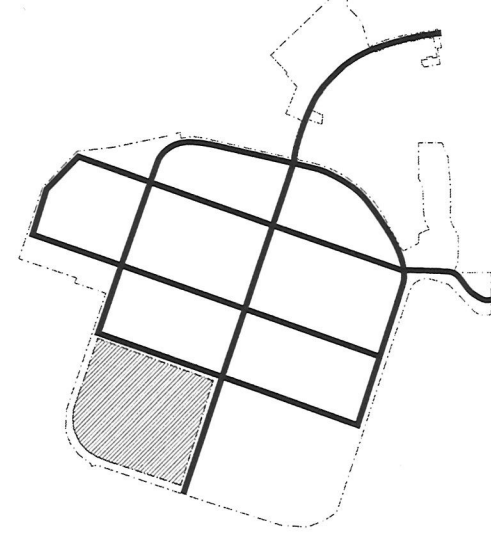

- Concepto 1 - Bucle
- Concepto 2 - Bulevar
- Concepto 3 - Cuadrícula

De las tres imágenes, ¿qué configuración de parque/espacio abierto prefieres? (Elige 1)

Concepto 1 - Consolidado

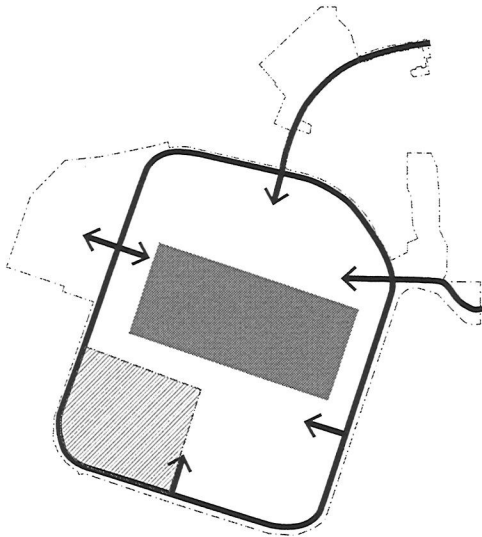

Concepto 2 - Distribuido

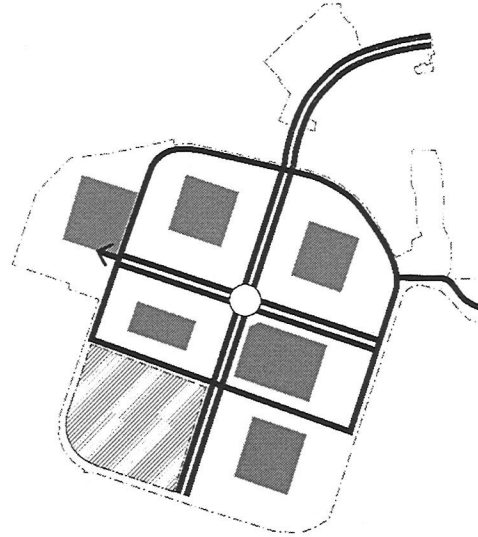

Concepto 3 - Combinación

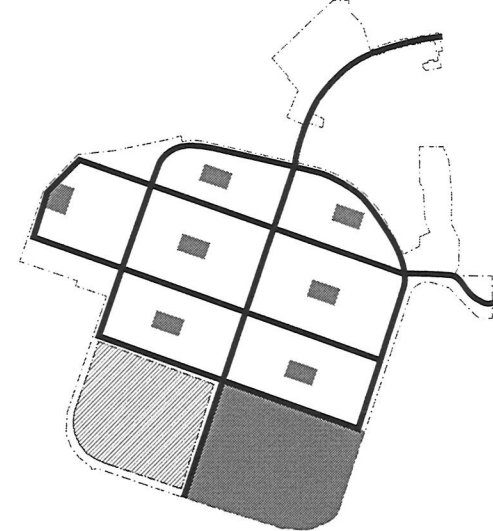

- Concepto 1 - Consolidado
- Concepto 2 - Distribuido
- Concepto 3 - Combinación

¡Cuéntanos más sobre ti! ¿Cuál es tu afiliación con Costa Mesa?

- Soy residente
- Soy de una ONG/Sin Fines de Lucro
- Soy propietario de un negocio
- Soy promotor
- Soy propietario
- Otros

Para las zonas de espacios abiertos activos, ¿qué tipos de instalaciones prefieres? (Elige 2)

- Campos de fútbol
- Campos de béisbol
- Parques infantiles
- Centro recreativo
- Senderos

¿Qué medios de transporte alternativos prefieres? (Elige 2)

- Caminar
- Bicicleta
- Carro de golf (o Vehículo Eléctrico Vecinal)
- Scooter
- Tránsito

De las tres imágenes, ¿qué concepto de circulación prefieres? (Elige 1)

Concepto 1 - Bucle

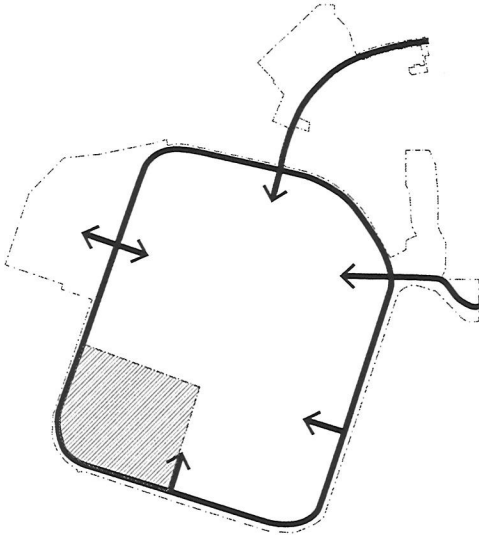

Concepto 2 - Bulevar

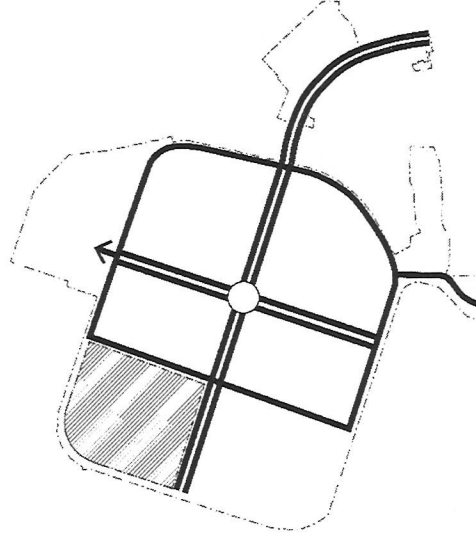

Concepto 3 - Cuadrícula

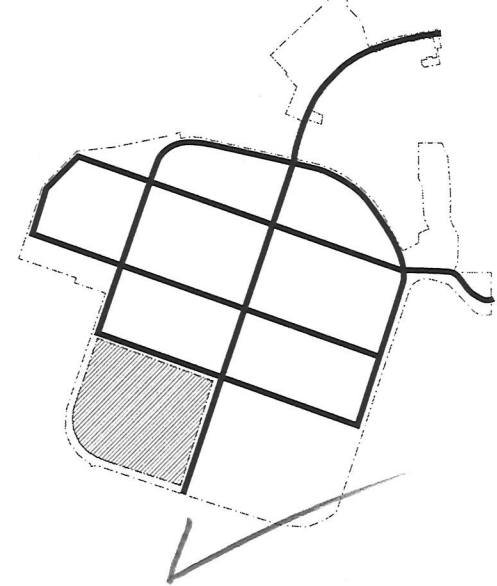

- Concepto 1 - Bucle
- Concepto 2 - Bulevar
- Concepto 3 - Cuadrícula

De las tres imágenes, ¿qué configuración de parque/espacio abierto prefieres? (Elige 1)

Concepto 1- Consolidado

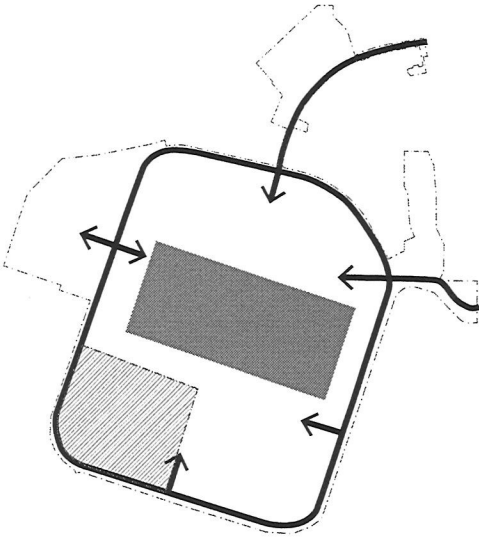

Concepto 2 - Distribuido

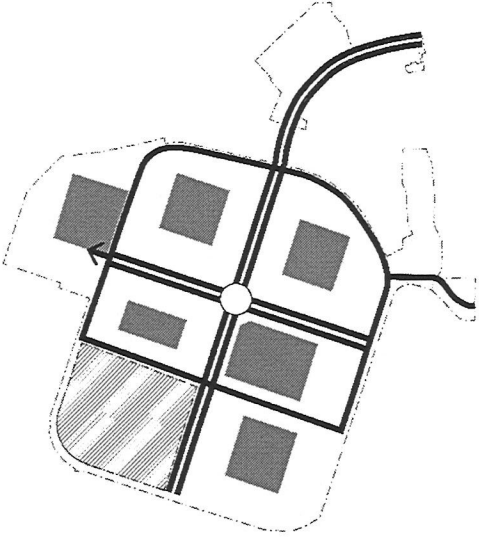

Concepto 3 - Combinación

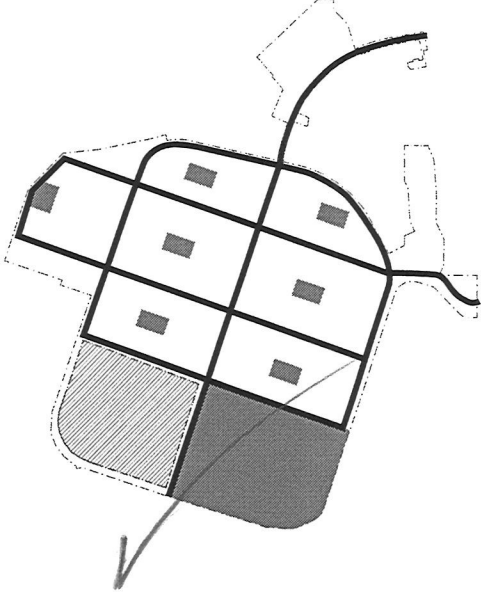

- Concepto 1- Consolidado
- Concepto 2 - Distribuido
- Concepto 3 - Combinación

¡Cuéntanos más sobre ti! ¿Cuál es tu afiliación con Costa Mesa?

- Soy residente
- Soy de una ONG/Sin Fines de Lucro
- Soy propietario de un negocio
- Soy promotor
- Soy propietario
- Otros

Para las zonas de espacios abiertos activos, ¿qué tipos de instalaciones prefieres? (Elige 2)

- Campos de fútbol
- Campos de béisbol
- Parques infantiles
- Centro recreativo
- Senderos

¿Qué medios de transporte alternativos prefieres? (Elige 2)

- Caminar
- Bicicleta
- Carro de golf (o Vehículo Eléctrico Vecinal)
- Scooter
- Tránsito

De las tres imágenes, ¿qué concepto de circulación prefieres? (Elige 1)

Concepto 1 - Bucle

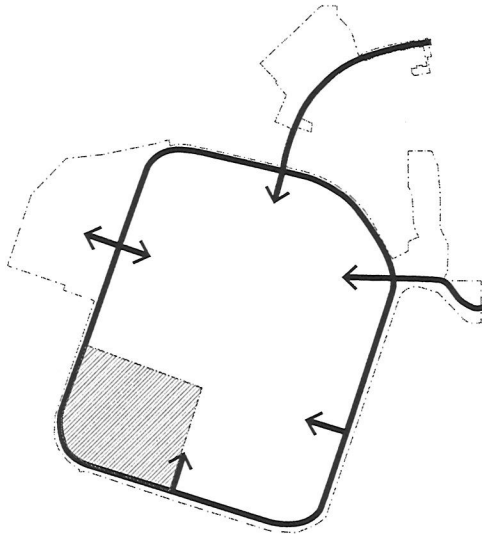

Concepto 2 - Bulevar

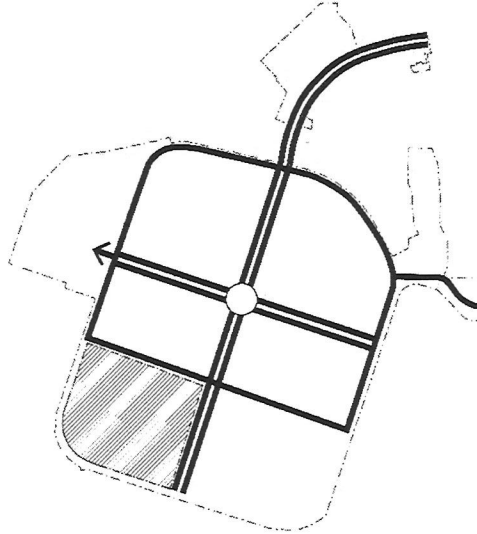

Concepto 3 - Cuadrícula

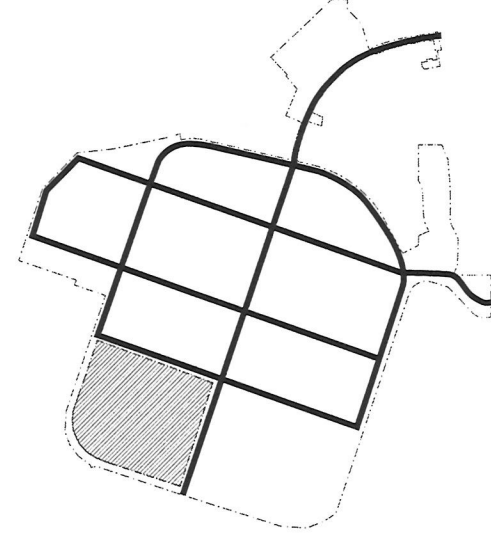

- Concepto 1 - Bucle
- Concepto 2 - Bulevar
- Concepto 3 - Cuadrícula

De las tres imágenes, ¿qué configuración de parque/espacio abierto prefieres? (Elige 1)

Concepto 1 - Consolidado

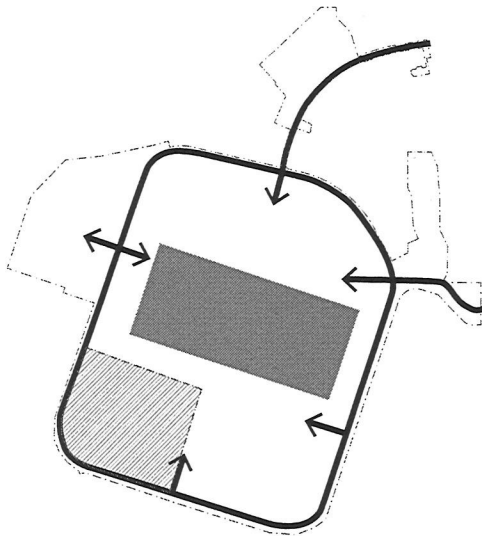

Concepto 2 - Distribuido

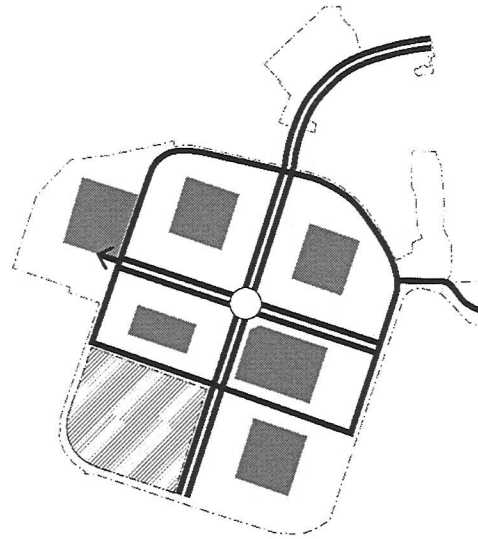

Concepto 3 - Combinación

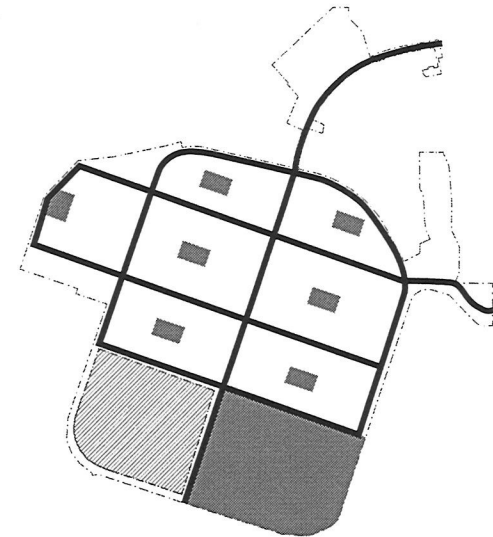

- Concepto 1 - Consolidado
- Concepto 2 - Distribuido
- Concepto 3 - Combinación

¡Cuéntanos más sobre ti! ¿Cuál es tu afiliación con Costa Mesa?

- Soy residente
- Soy de una ONG/Sin Fines de Lucro
- Soy propietario de un negocio
- Soy promotor
- Soy propietario
- Otros

Para las zonas de espacios abiertos activos, ¿qué tipos de instalaciones prefieres? (Elige 2)

- Campos de fútbol
- Campos de béisbol
- Parques infantiles
- Centro recreativo
- Senderos

¿Qué medios de transporte alternativos prefieres? (Elige 2)

- Caminar
- Bicicleta
- Carro de golf (o Vehículo Eléctrico Vecinal)
- Scooter
- Tránsito

De las tres imágenes, ¿qué concepto de circulación prefieres? (Elige 1)

Concepto 1 - Bucle

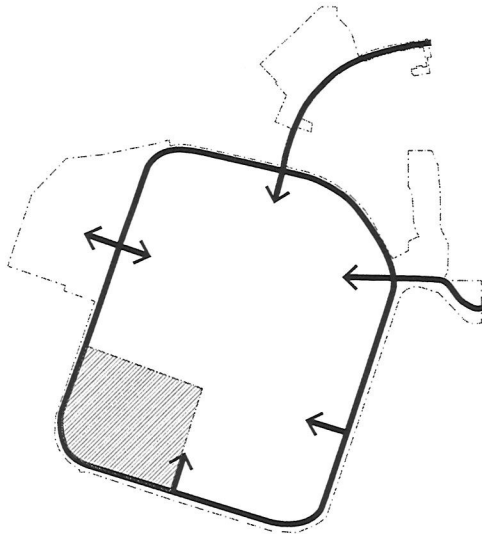

Concepto 2 - Bulevar

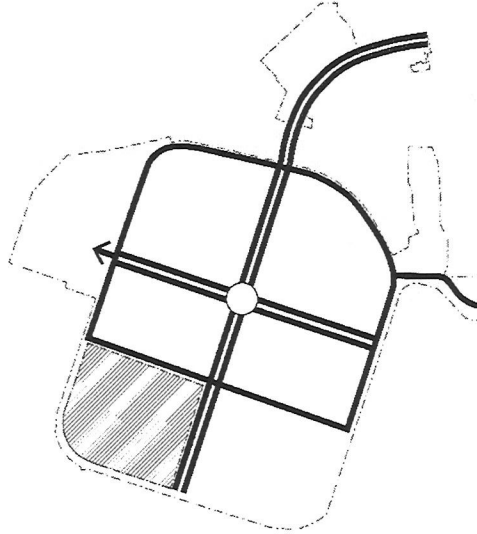

Concepto 3 - Cuadrícula

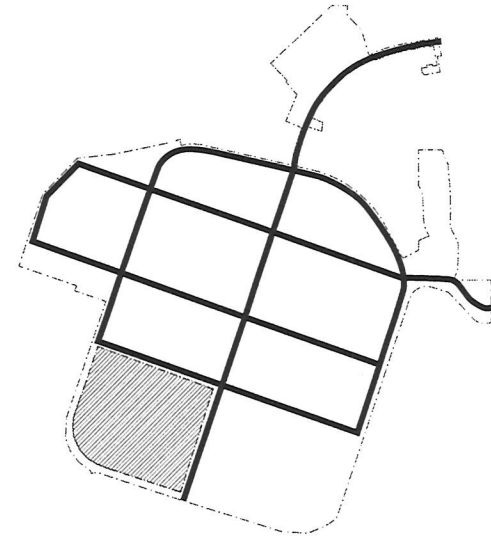

- Concepto 1 - Bucle
- Concepto 2 - Bulevar
- Concepto 3 - Cuadrícula

De las tres imágenes, ¿qué configuración de parque/espacio abierto prefieres? (Elige 1)

Concepto 1- Consolidado

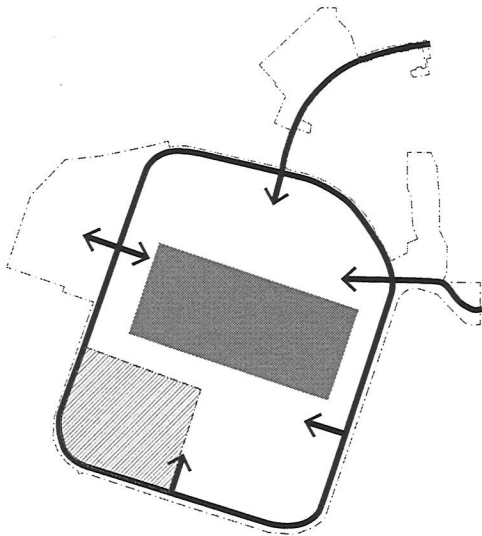

Concepto 2 - Distribuido

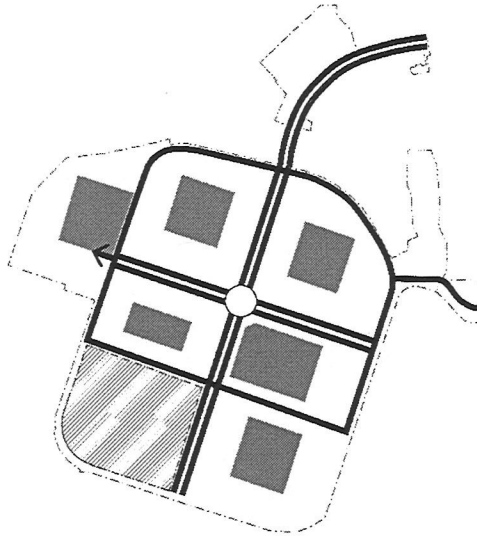

Concepto 3 - Combinación

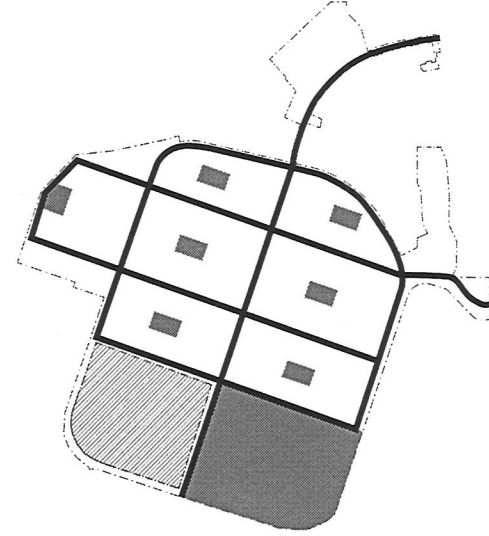

- Concepto 1- Consolidado
- Concepto 2 - Distribuido
- Concepto 3 - Combinación

¡Cuéntanos más sobre ti! ¿Cuál es tu afiliación con Costa Mesa?

- Soy residente
- Soy de una ONG/Sin Fines de Lucro
- Soy propietario de un negocio
- Soy promotor
- Soy propietario
- Otros

Para las zonas de espacios abiertos activos, ¿qué tipos de instalaciones prefieres? (Elige 2)

- Campos de fútbol
- Campos de béisbol
- Parques infantiles
- Centro recreativo
- Senderos

¿Qué medios de transporte alternativos prefieres? (Elige 2)

- Caminar
- Bicicleta
- Carro de golf (o Vehículo Eléctrico Vecinal)
- Scooter
- Tránsito

De las tres imágenes, ¿qué concepto de circulación prefieres? (Elige 1)

Concepto 1 - Bucle

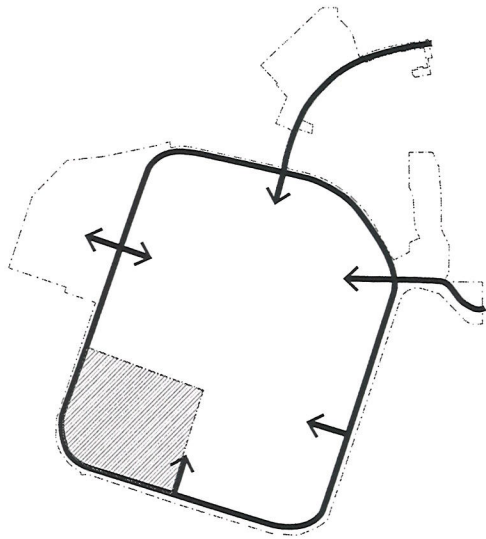

Concepto 2 - Bulevar

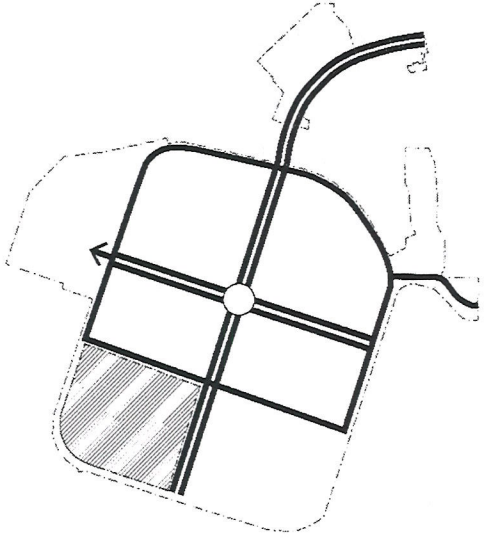

Concepto 3 - Cuadrícula

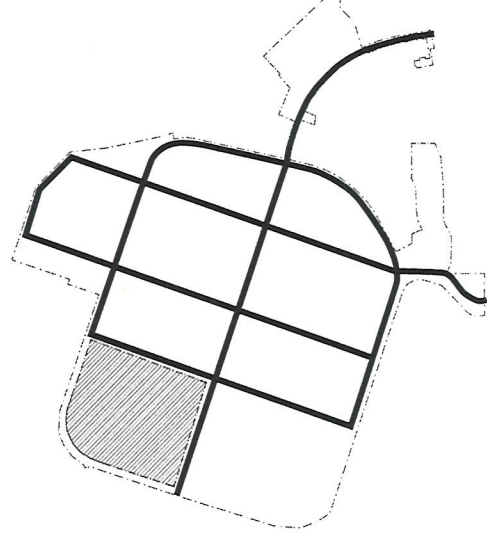

- Concepto 1 - Bucle
- Concepto 2 - Bulevar
- Concepto 3 - Cuadrícula

De las tres imágenes, ¿qué configuración de parque/espacio abierto prefieres? (Elige 1)

Concepto 1- Consolidado

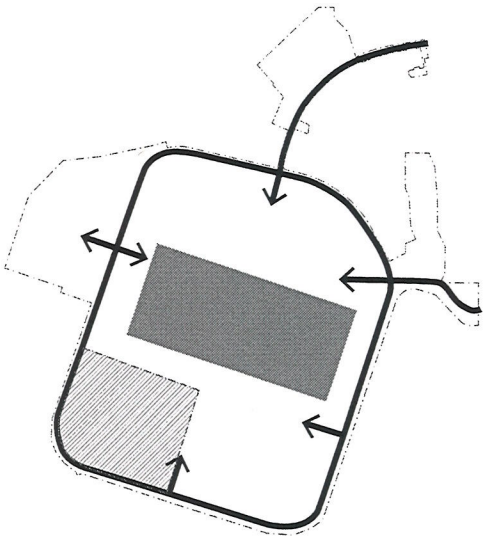

Concepto 2 - Distribuido

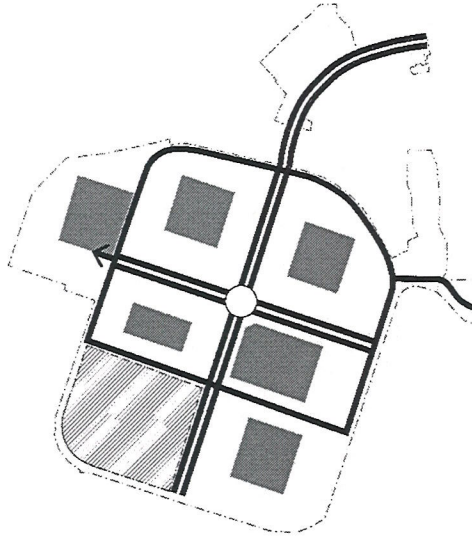

Concepto 3 - Combinación

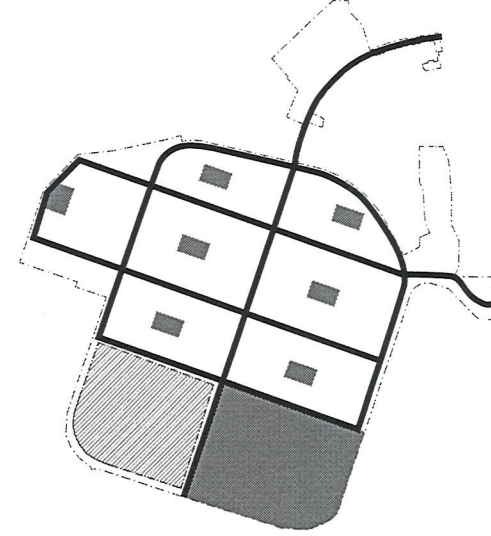

- Concepto 1- Consolidado
- Concepto 2 - Distribuido
- Concepto 3 - Combinación



Tell us more about you! What is your affiliation with Costa Mesa?

- I'm a resident
- resident activist
- I'm with an NGO/Non-Profit
- I'm a business owner
- I'm a developer
- I'm a property owner
- Other

For active open space areas, what types of facilities do you prefer? (Choose 2)

- Soccer fields
- pickleball and tennis
- Baseball fields
- Playgrounds
- Recreation Center
- Trails

What alternative modes of transportation do you prefer? (Choose 2)

- Walking
- Biking
- Golf Cart (or Neighborhood Electric Vehicle)
- Scooter
- Transit

Of the three images, which circulation concept do you prefer? (Choose 1)

Concept 1 - Loop

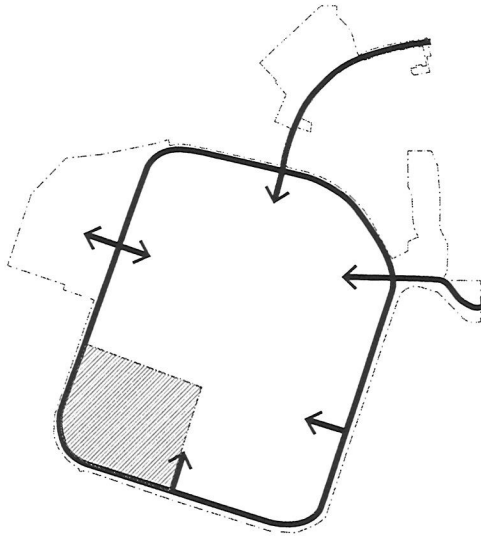

Concept 2 - Boulevard

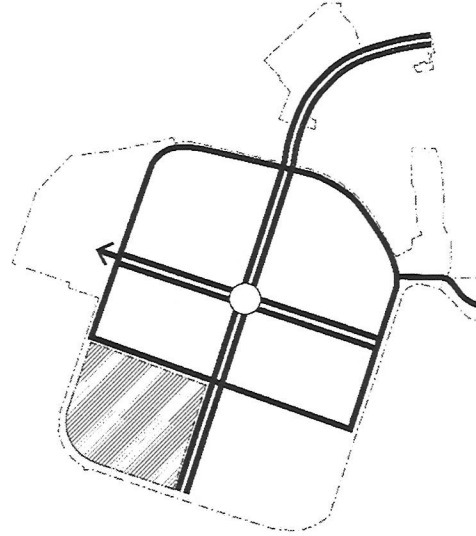

Concept 3 - Grid

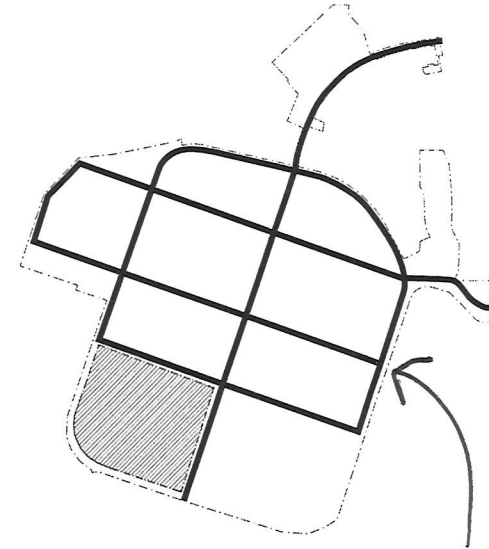

- Concept 1 – Loop
- Concept 2 – Boulevard
- Concept 3 – Grid

THIS WITH
A 15 MPH
SPEED
LIMIT

Of the three images, which park/open space configuration do you prefer? (Choose 1)

Concept 1 - Consolidated

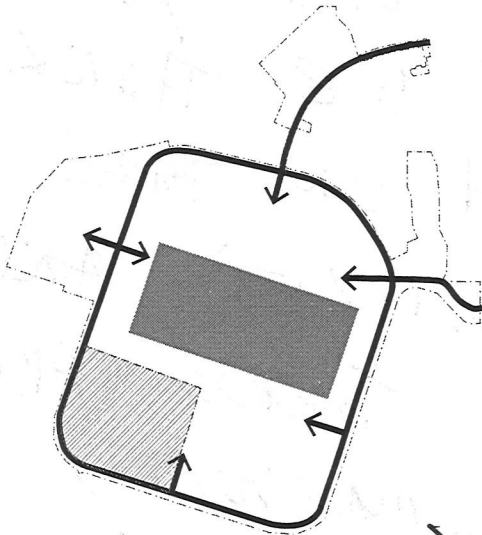

Concept 2 - Distributed

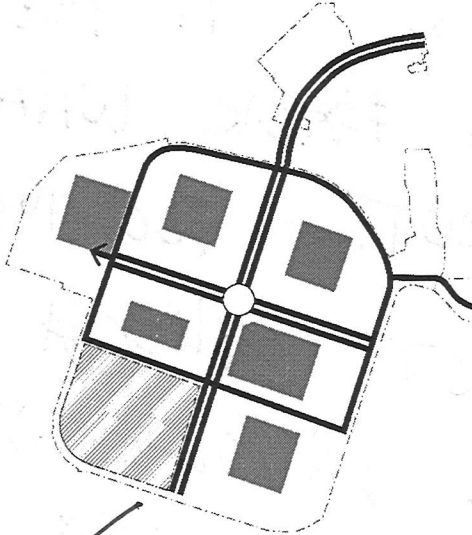

Concept 3 - Combination

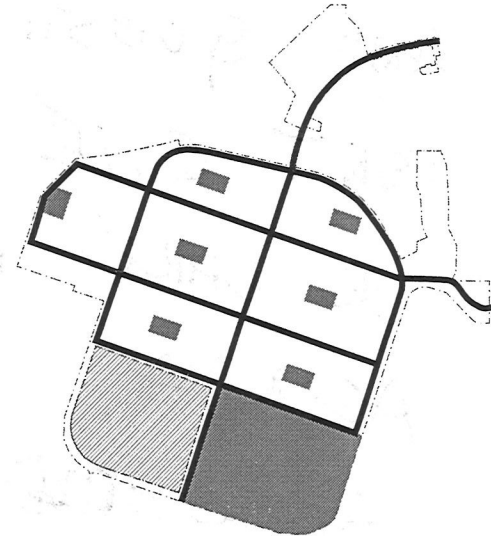

- Concept 1 – Consolidated
- Concept 2 – Distributed
- Concept 3 – Combination

A
COMBINATION
OF THE
TWO

↑
CANT PUT IT
THERE – EOC
HAS A ROAD
THRU IT

OVER ↗

THIS WAS A SHITSHOW. YOU ARE NOT
ALLOWING ENOUGH TIME FOR COMMENTS
AND QUESTIONS. IT FEELS LIKE YOU
DON'T GIVE A F*CK WHAT WE THINK
OR CARE ABOUT. TOO MUCH ON THE
AGENDA. NOT ENOUGH CITIZEN AND
STAKEHOLDER INVOLVEMENT. THERE ARE
MANY EXPERTS IN OUR COMMUNITY
WHO COULD WRITE BETTER PRINCIPLES
AND A BETTER VISION STATEMENT THAT
REFLECTS WHAT THE PARTICIPANTS OF
THE FIRST MEETING EXPRESSED.



Tell us more about you! What is your affiliation with Costa Mesa?

- I'm a resident
- I'm with an NGO/Non-Profit
- I'm a business owner
- I'm a developer
- I'm a property owner
- Other

For active open space areas, what types of facilities do you prefer? (Choose 2)

- Soccer fields
- Baseball fields
- Playgrounds
- Recreation Center
- Trails
Pickleball / Tennis

What alternative modes of transportation do you prefer? (Choose 2)

- Walking
- Biking
- Golf Cart (or Neighborhood Electric Vehicle)
- Scooter
- Transit

Of the three images, which circulation concept do you prefer? (Choose 1)

Concept 1 - Loop

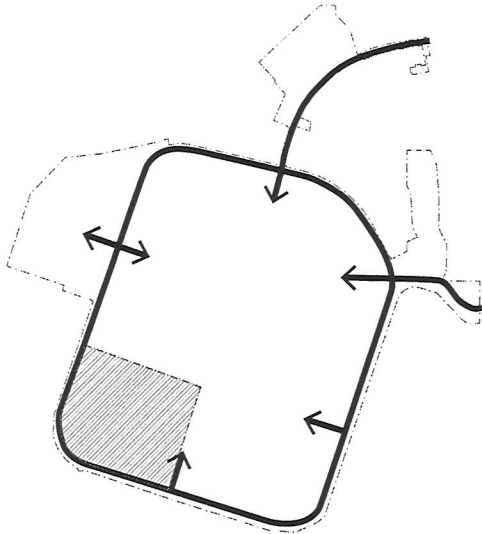

Concept 2 - Boulevard

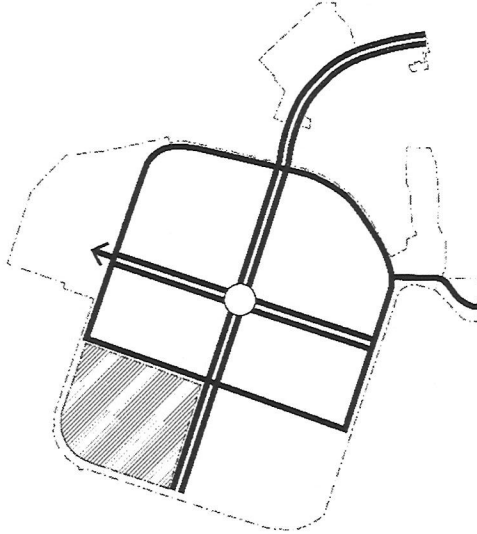

Concept 3 - Grid

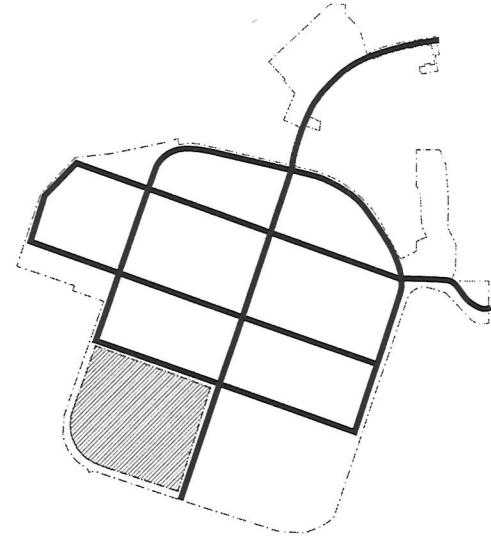

- Concept 1 – Loop
- Concept 2 – Boulevard
- Concept 3 – Grid

Of the three images, which park/open space configuration do you prefer? (Choose 1)

Concept 1 - Consolidated

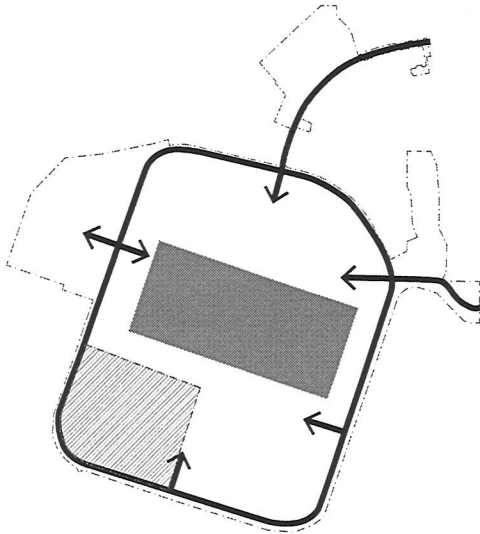

Concept 2 - Distributed

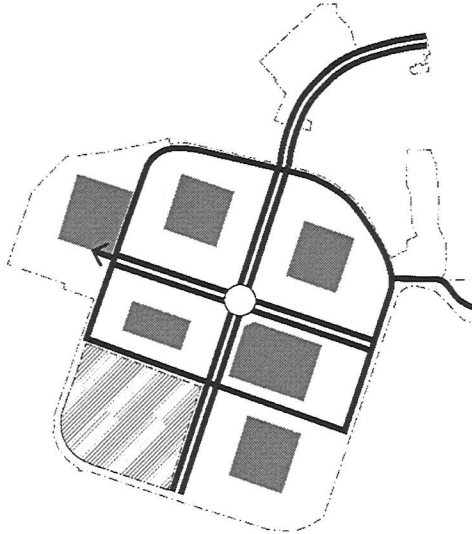

Concept 3 - Combination

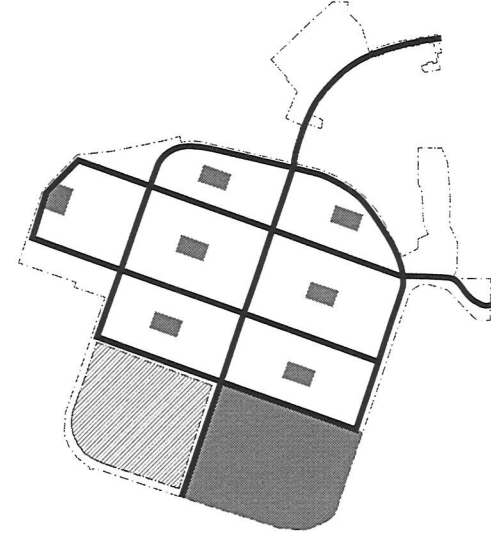

- Concept 1 – Consolidated
- Concept 2 – Distributed
- Concept 3 – Combination



Tell us more about you! What is your affiliation with Costa Mesa?

- I'm a resident
- I'm with an NGO/Non-Profit
- I'm a business owner
- I'm a developer
- I'm a property owner
- Other

For active open space areas, what types of facilities do you prefer? (Choose 2)

- Soccer fields
- Baseball fields
- Playgrounds
- Recreation Center
- Trails

What alternative modes of transportation do you prefer? (Choose 2)

- Walking
- Biking
- Golf Cart (or Neighborhood Electric Vehicle)
- Scooter
- Transit

Of the three images, which circulation concept do you prefer? (Choose 1)

Concept 1 - Loop

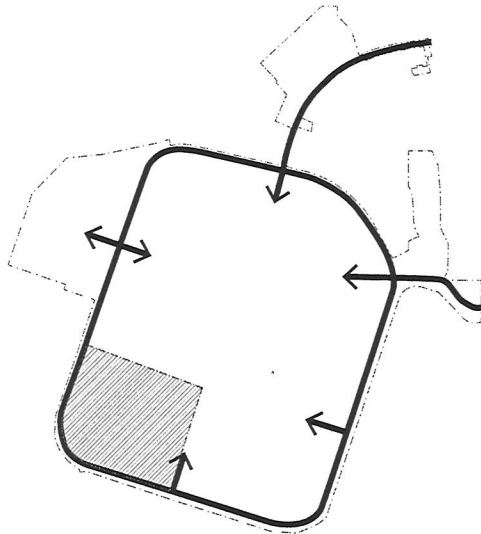

Concept 2 - Boulevard

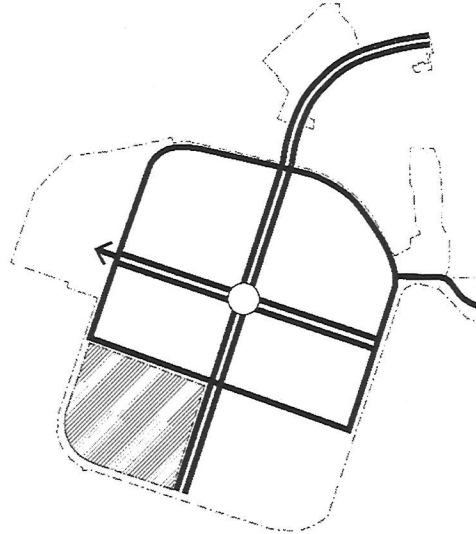

Concept 3 - Grid

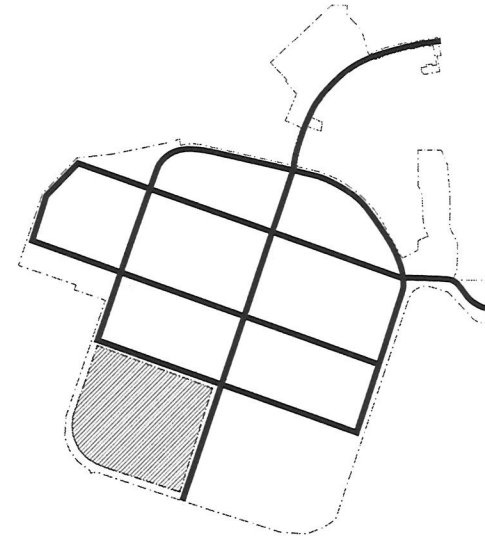

- Concept 1 – Loop
- Concept 2 – Boulevard
- Concept 3 – Grid

Of the three images, which park/open space configuration do you prefer? (Choose 1)

Concept 1 - Consolidated

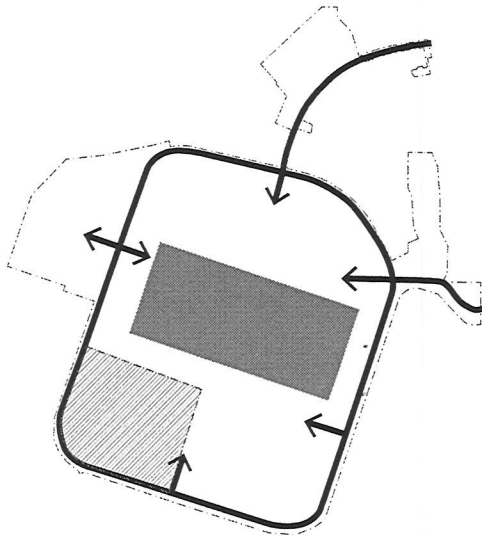

Concept 2 - Distributed

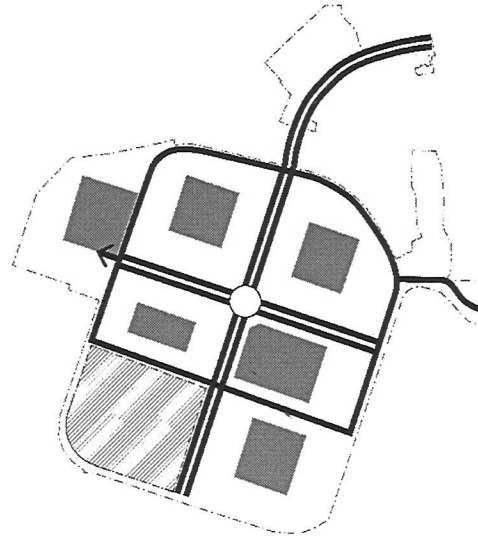

Concept 3 - Combination

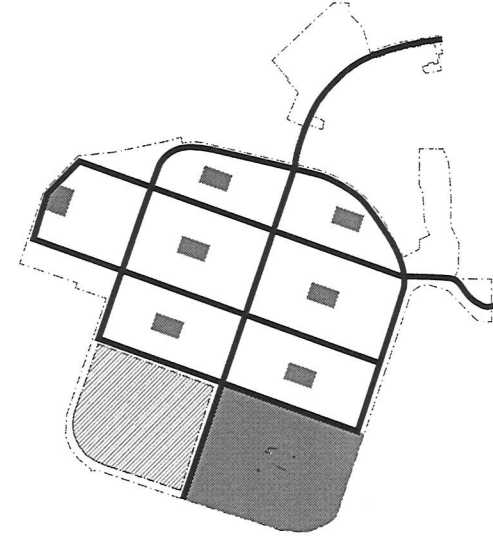

- Concept 1 – Consolidated
- Concept 2 – Distributed
- Concept 3 – Combination



Tell us more about you! What is your affiliation with Costa Mesa?

- I'm a resident
- I'm with an NGO/Non-Profit
- I'm a business owner
- I'm a developer
- I'm a property owner
- Other

For active open space areas, what types of facilities do you prefer? (Choose 2)

- Soccer fields
- Baseball fields
- Playgrounds
- Recreation Center
- Trails

What alternative modes of transportation do you prefer? (Choose 2)

- Walking
- Biking
- Golf Cart (or Neighborhood Electric Vehicle)
- Scooter
- Transit

Of the three images, which circulation concept do you prefer? (Choose 1)

Concept 1 - Loop

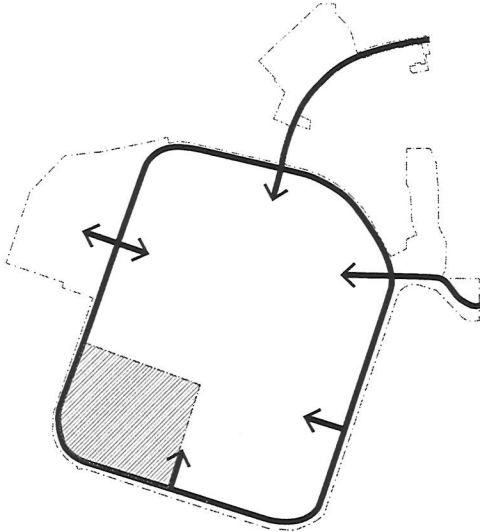

Concept 2 - Boulevard

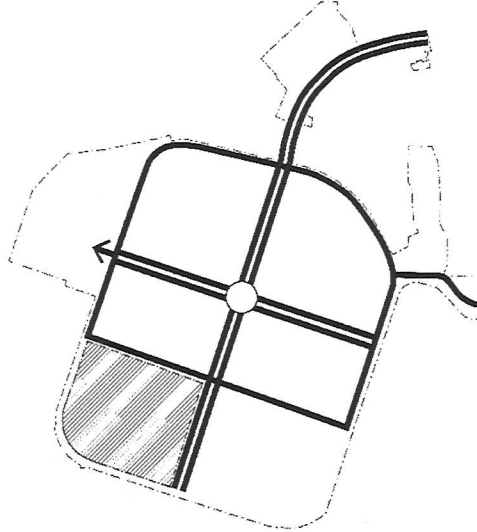

Concept 3 - Grid

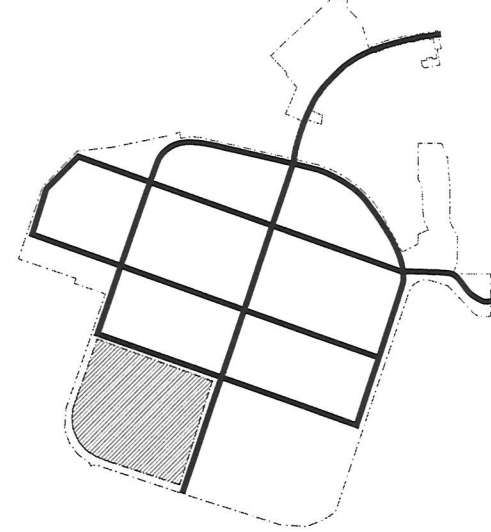

- Concept 1 – Loop
- Concept 2 – Boulevard
- Concept 3 – Grid

Of the three images, which park/open space configuration do you prefer? (Choose 1)

Concept 1 - Consolidated

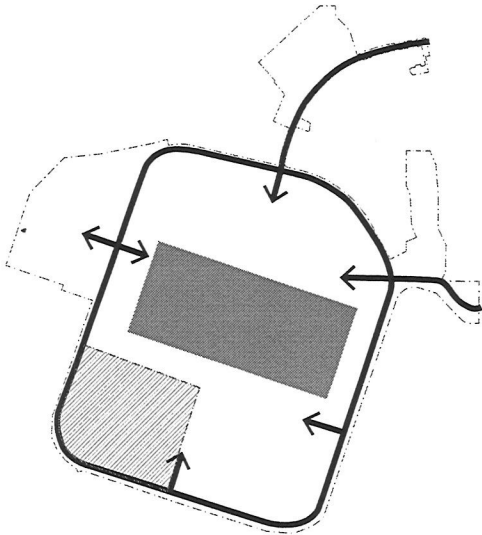

Concept 2 - Distributed

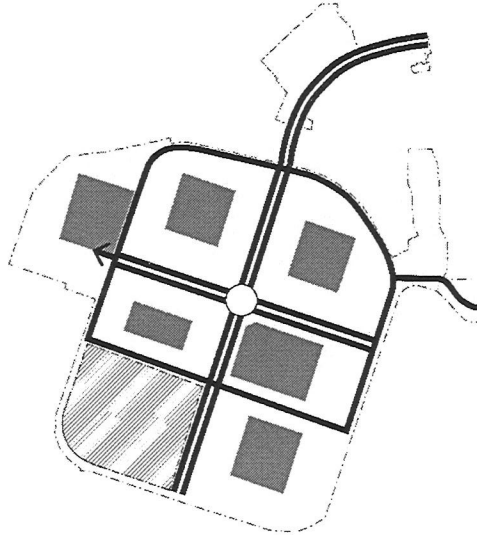

Concept 3 - Combination

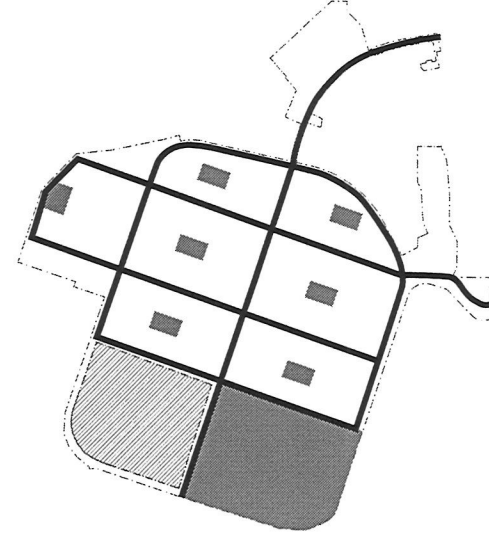

- Concept 1 – Consolidated
- Concept 2 – Distributed
- Concept 3 – Combination

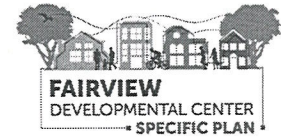

Tell us more about you! What is your affiliation with Costa Mesa?

- I'm a resident
- I'm with an NGO/Non-Profit
- I'm a business owner
- I'm a developer
- I'm a property owner
- Other

For active open space areas, what types of facilities do you prefer? (Choose 2)

- Soccer fields
- Baseball fields
- Playgrounds
- Recreation Center
- Trails
- Pickleball courts

What alternative modes of transportation do you prefer? (Choose 2)

- Walking
- Biking
- Golf Cart (or Neighborhood Electric Vehicle)
- Scooter
- Transit

Of the three images, which circulation concept do you prefer? (Choose 1)

Concept 1 - Loop

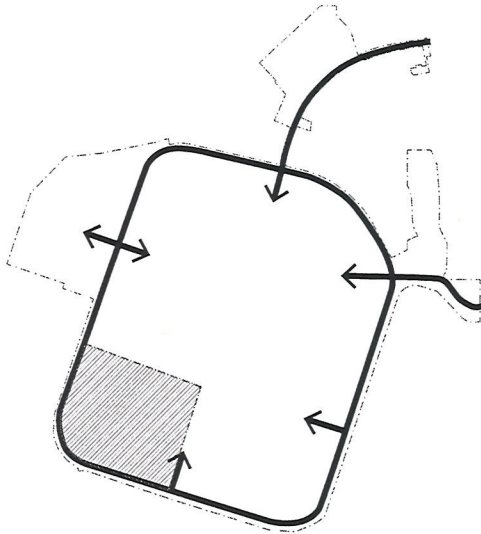

Concept 2 - Boulevard

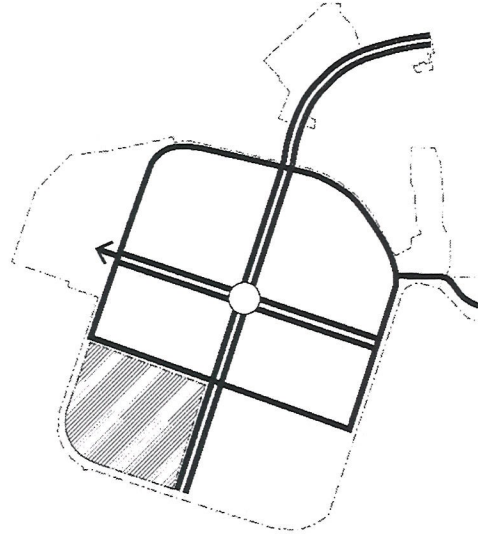

Concept 3 - Grid

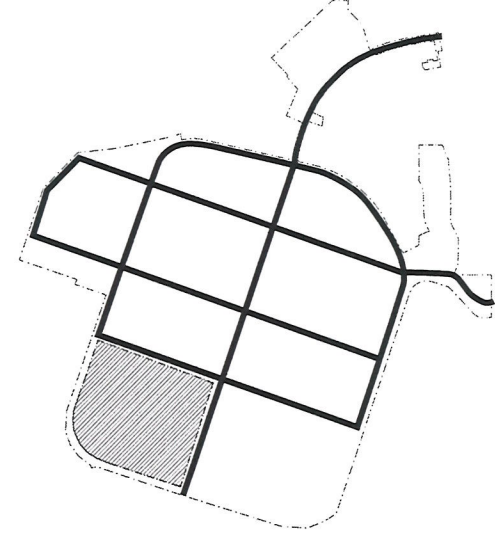

- Concept 1 – Loop
- Concept 2 – Boulevard
- Concept 3 – Grid

Of the three images, which park/open space configuration do you prefer? (Choose 1)

Concept 1 - Consolidated

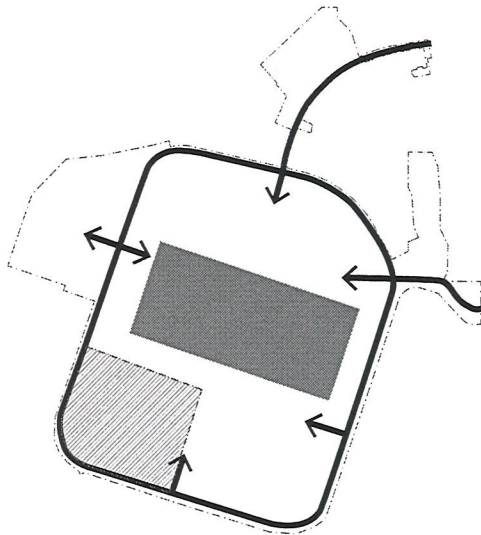

Concept 2 - Distributed

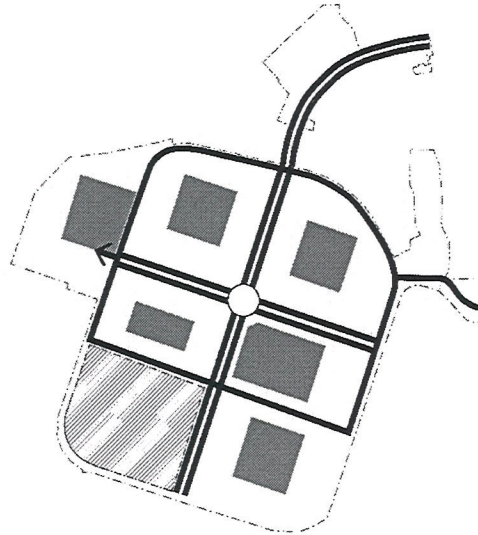

Concept 3 - Combination

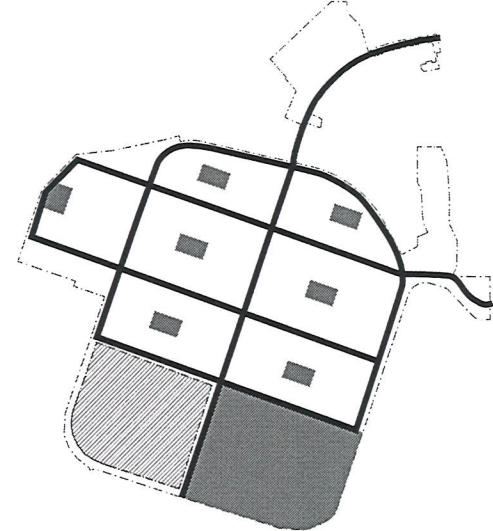

- Concept 1 – Consolidated
- Concept 2 – Distributed
- Concept 3 – Combination



DAN THOMPSON
2751 CANARY DR, C.M.

Tell us more about you! What is your affiliation with Costa Mesa?

- I'm a resident
- I'm with an NGO/Non-Profit
- I'm a business owner
- I'm a developer *OF COMEDY*
- I'm a property owner
- Other *GAD FLY*

For active open space areas, what types of facilities do you prefer? (Choose 2)

- Soccer fields
- Baseball fields
- Playgrounds
- Recreation Center
- Trails
- PICKLE BALL*

What alternative modes of transportation do you prefer? (Choose 2)

- Walking
- Biking
- Golf Cart (or Neighborhood Electric Vehicle)
- Scooter
- Transit
- TELEPORTATION*

Of the three images, which circulation concept do you prefer? (Choose 1)

Concept 1 - Loop

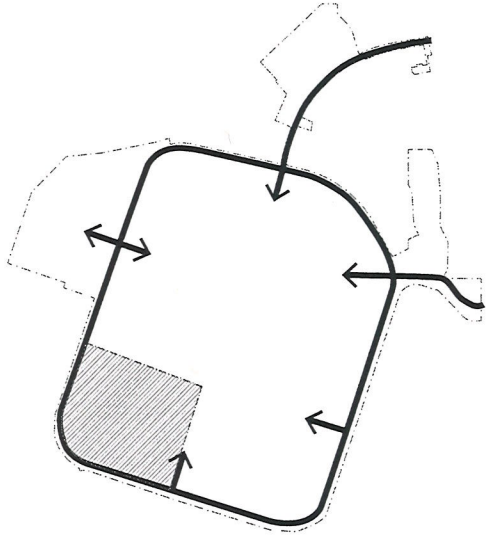

Concept 2 - Boulevard

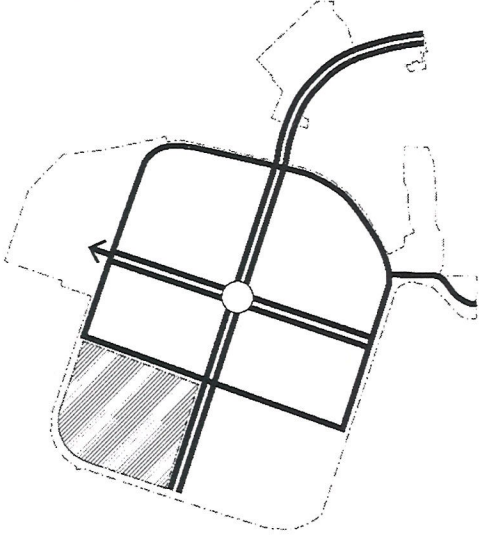

Concept 3 - Grid

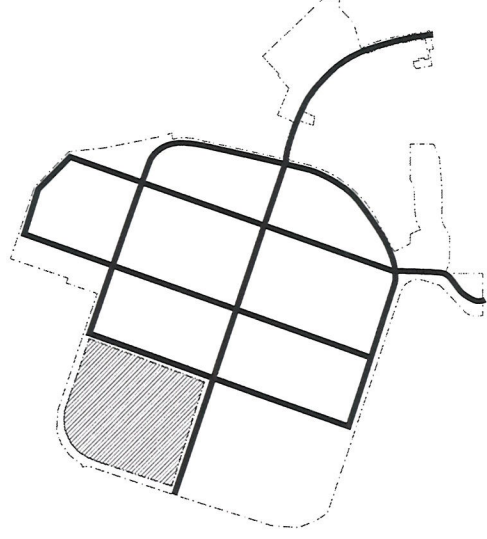

- Concept 1 – Loop
- Concept 2 – Boulevard
- Concept 3 – Grid
- RACEWAY*

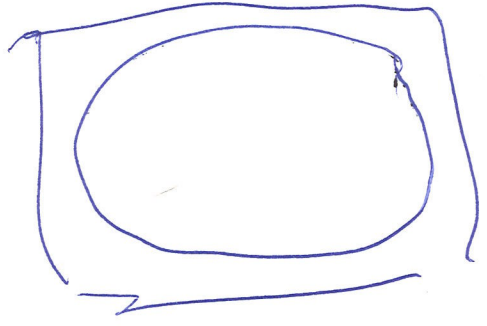

Of the three images, which park/open space configuration do you prefer? (Choose 1)

Concept 1 - Consolidated

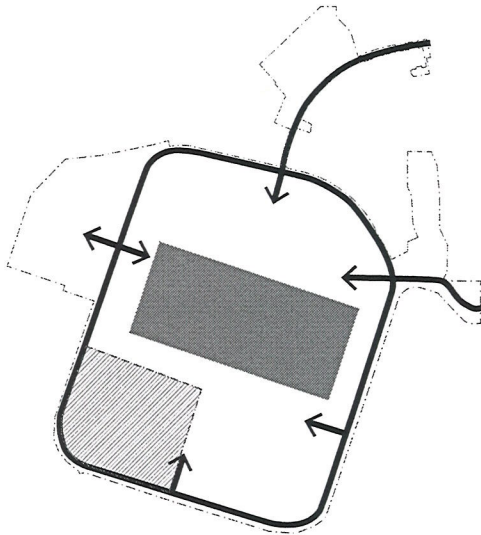

Concept 2 - Distributed

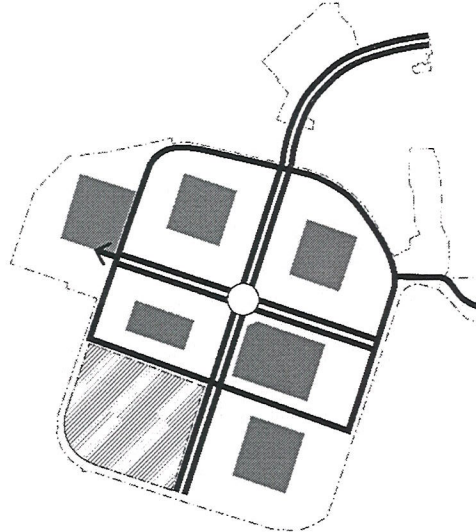

Concept 3 - Combination

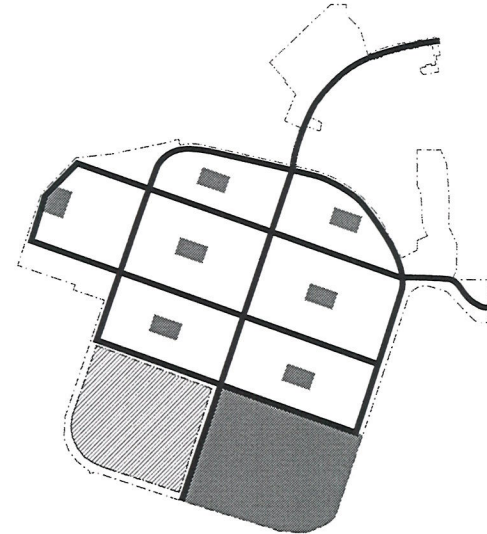

- Concept 1 – Consolidated *- NFL SIZE FIELD*
- Concept 2 – Distributed
- Concept 3 – Combination



Tell us more about you! What is your affiliation with Costa Mesa?

- I'm a resident
- I'm with an NGO/Non-Profit
- I'm a business owner
- I'm a developer
- I'm a property owner
- Other *Retired senior woman; Caregiver work*

For active open space areas, what types of facilities do you prefer? (Choose 2)

- Soccer fields
- Baseball fields
- Playgrounds
- Recreation Center
- Trails

What alternative modes of transportation do you prefer? (Choose 2)

- Walking
- Biking
- Golf Cart (or Neighborhood Electric Vehicle)
- Scooter
- Transit

Of the three images, which circulation concept do you prefer? (Choose 1)

Concept 1 - Loop

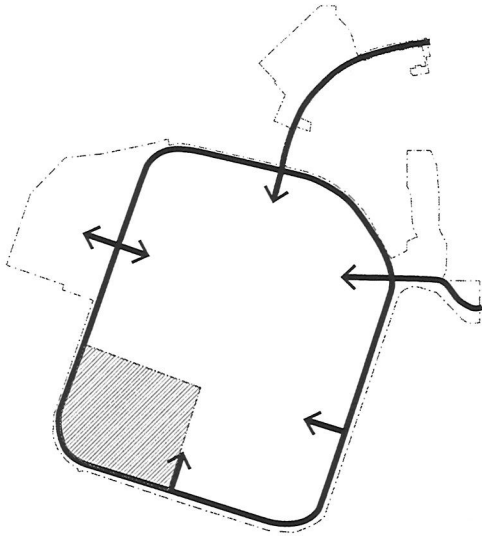

Concept 2 - Boulevard

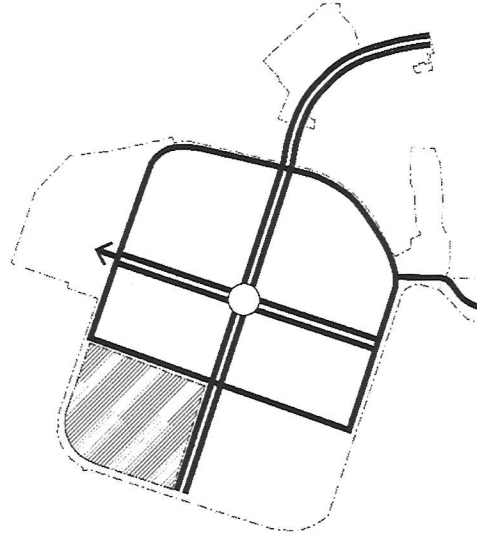

Concept 3 - Grid

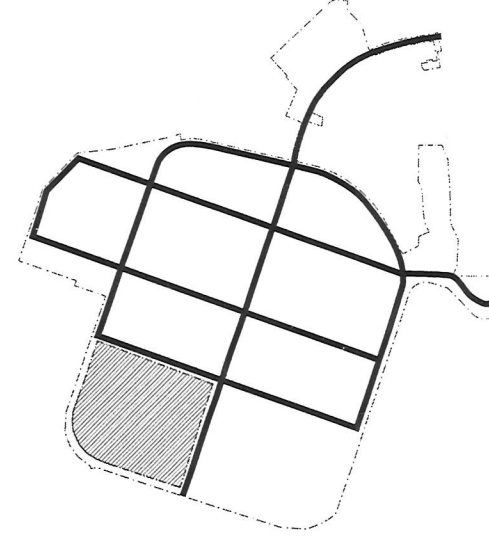

- Concept 1 – Loop
- Concept 2 – Boulevard
- Concept 3 – Grid

Of the three images, which park/open space configuration do you prefer? (Choose 1)

Concept 1 - Consolidated

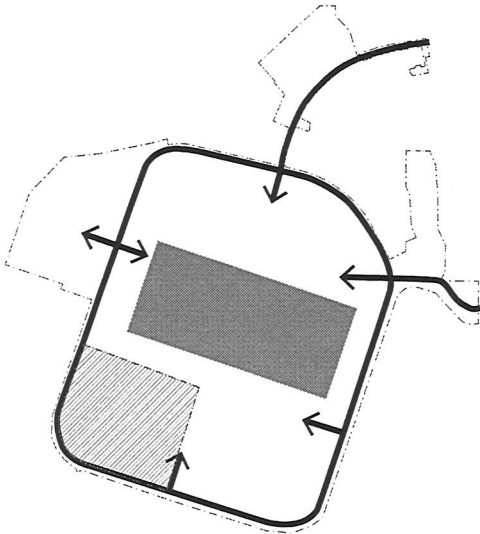

Concept 2 - Distributed

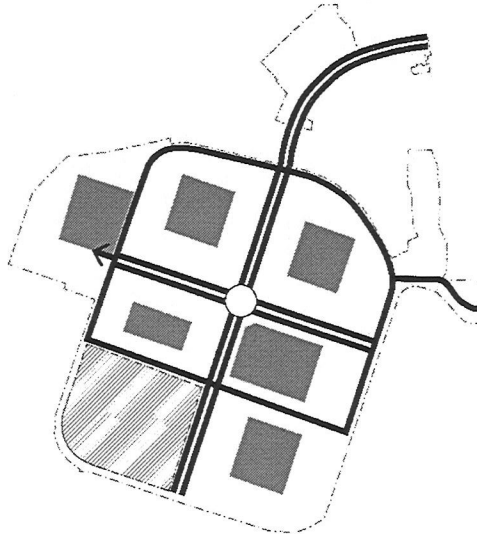

Concept 3 - Combination

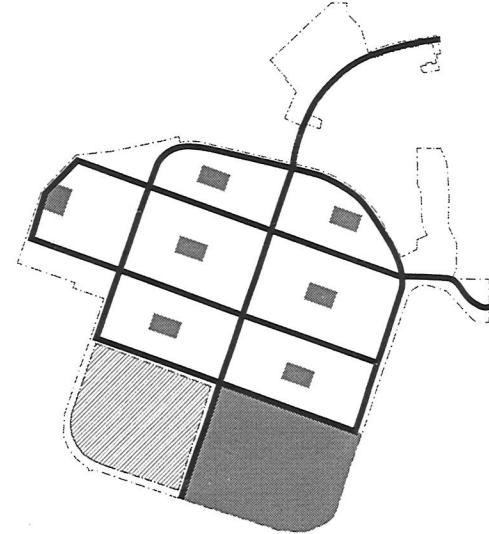

- Concept 1 – Consolidated
- Concept 2 – Distributed
- Concept 3 – Combination



Tell us more about you! What is your affiliation with Costa Mesa?

- I'm a resident
- I'm with an NGO/Non-Profit
- I'm a business owner
- I'm a developer
- I'm a property owner
- Other

For active open space areas, what types of facilities do you prefer? (Choose 2)

- Soccer fields
- Baseball fields
- Playgrounds
- Recreation Center
- Trails

What alternative modes of transportation do you prefer? (Choose 2)

- Walking
- Biking
- Golf Cart (or Neighborhood Electric Vehicle)
- Scooter
- Transit

Of the three images, which circulation concept do you prefer? (Choose 1)

Concept 1 - Loop

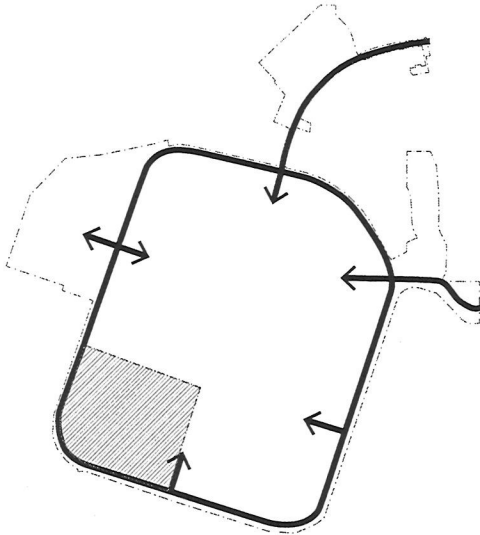

Concept 2 - Boulevard

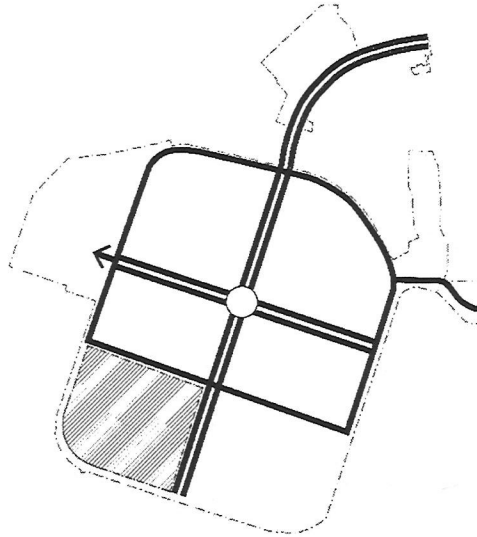

Concept 3 - Grid

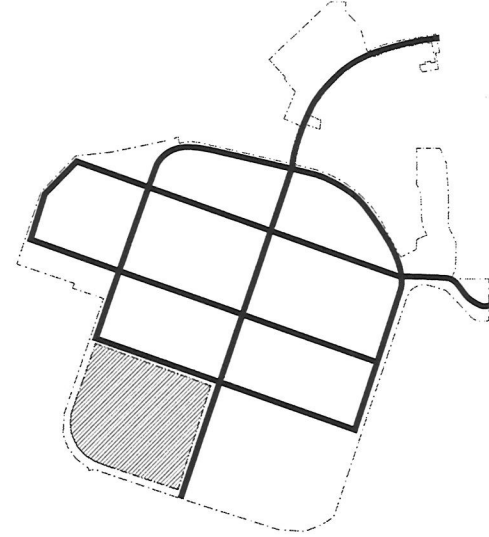

- Concept 1 – Loop
- Concept 2 – Boulevard
- Concept 3 – Grid

Of the three images, which park/open space configuration do you prefer? (Choose 1)

Concept 1 - Consolidated

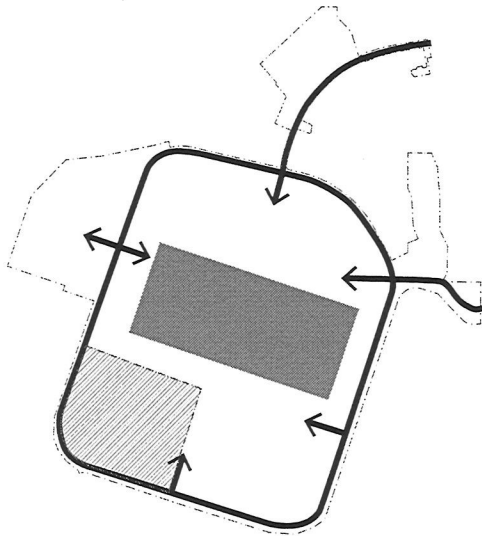

Concept 2 - Distributed

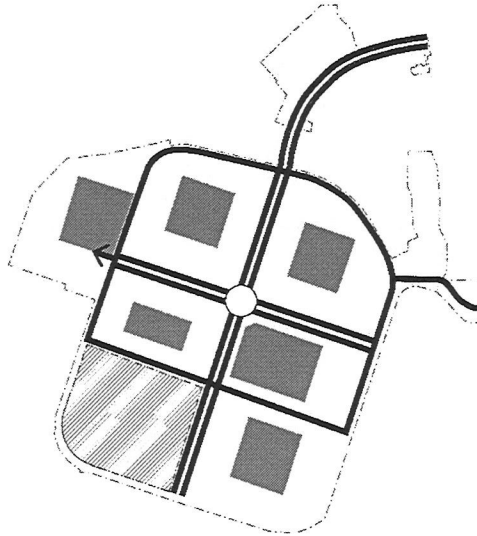

Concept 3 - Combination

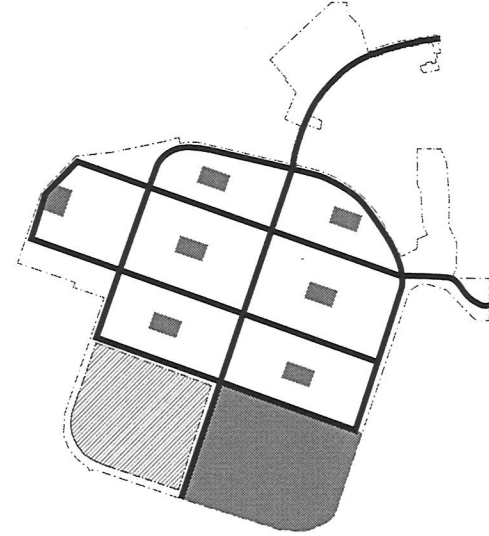

- Concept 1 – Consolidated
- Concept 2 – Distributed
- Concept 3 – Combination

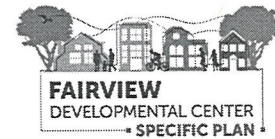

Tell us more about you! What is your affiliation with Costa Mesa?

- I'm a resident
- I'm with an NGO/Non-Profit
- I'm a business owner
- I'm a developer
- I'm a property owner
- Other

For active open space areas, what types of facilities do you prefer? (Choose 2)

- Soccer fields
 - Baseball fields
 - Playgrounds
 - Recreation Center
 - Trails
- Who MANAGES greens, maintenance, reservation needed, crowd control all a sports complex?*

What alternative modes of transportation do you prefer? (Choose 2)

- Walking
- Biking
- Golf Cart (or Neighborhood Electric Vehicle)
- Scooter
- Transit

Of the three images, which circulation concept do you prefer? (Choose 1)

Concept 1 - Loop

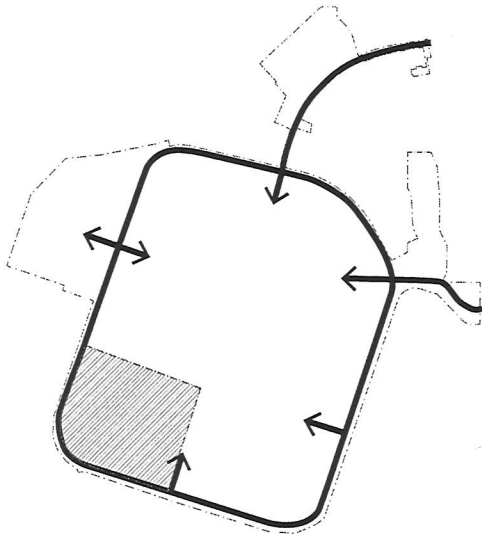

Concept 2 - Boulevard

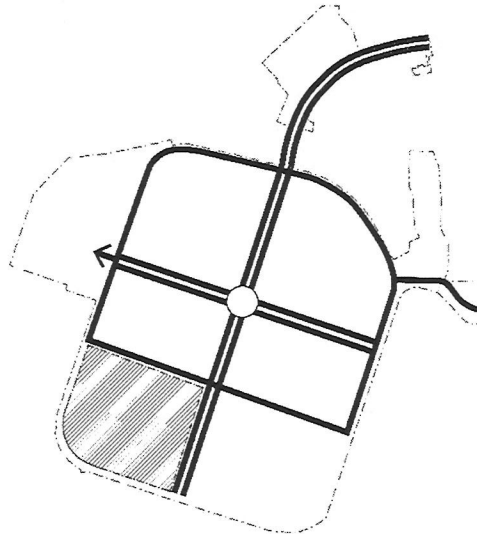

Concept 3 - Grid

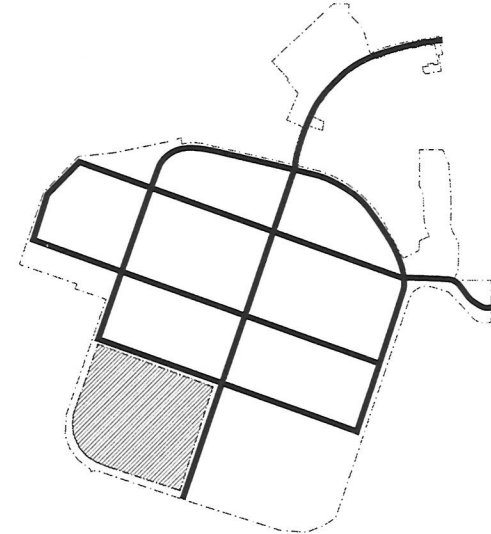

- Concept 1 – Loop
- Concept 2 – Boulevard
- Concept 3 – Grid

Of the three images, which park/open space configuration do you prefer? (Choose 1)

Concept 1 - Consolidated

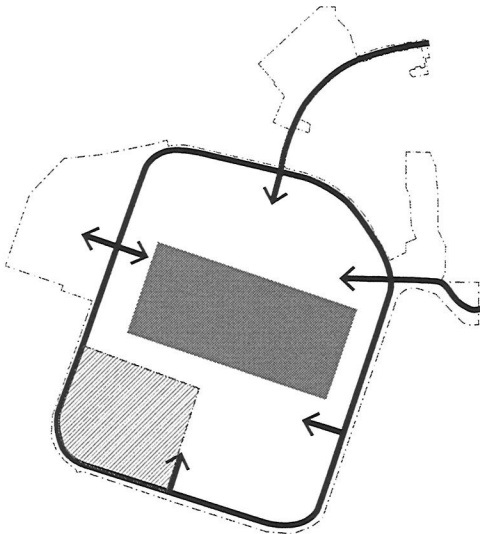

Concept 2 - Distributed

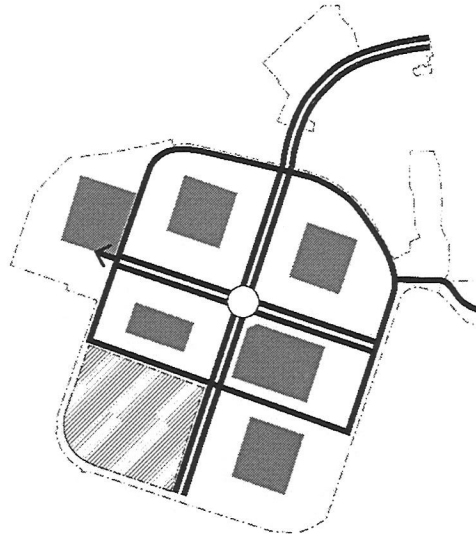

Concept 3 - Combination

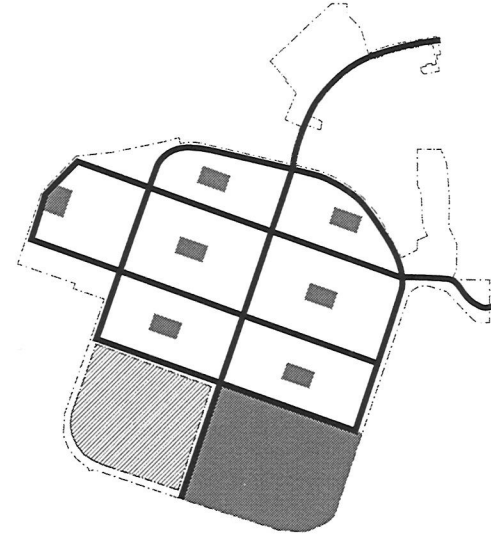

- Concept 1 – Consolidated
- Concept 2 – Distributed
- Concept 3 – Combination



Tell us more about you! What is your affiliation with Costa Mesa?

- I'm a resident
- I'm with an NGO/Non-Profit
- I'm a business owner
- I'm a developer
- I'm a property owner
- Other

*(Placeworks)
Consultant
for Project*

For active open space areas, what types of facilities do you prefer? (Choose 2)

- Soccer fields
- Baseball fields
- Playgrounds
- Recreation Center
- Trails = Green belt

What alternative modes of transportation do you prefer? (Choose 2)

- Walking
- Biking
- Golf Cart (or Neighborhood Electric Vehicle)
- Scooter
- Transit

Of the three images, which circulation concept do you prefer? (Choose 1)

Concept 1 - Loop

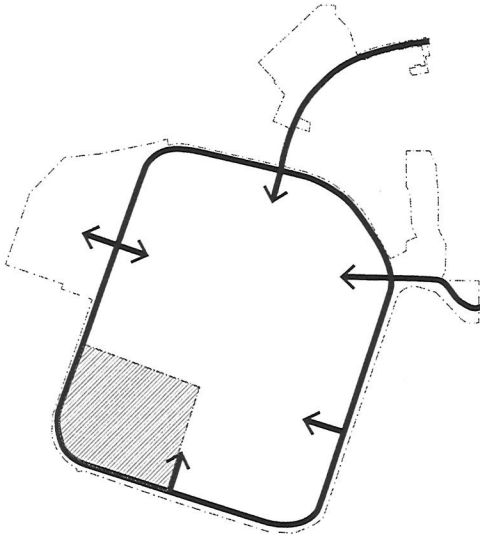

Concept 2 - Boulevard

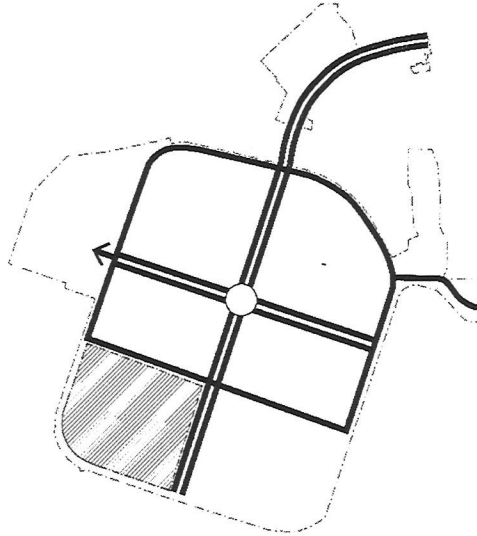

Concept 3 - Grid

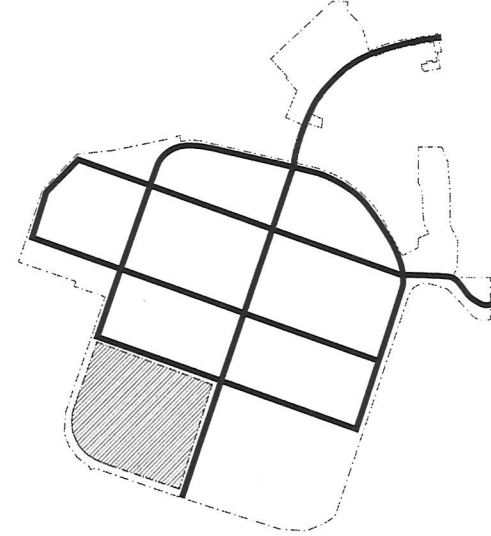

- Concept 1 – Loop
- Concept 2 – Boulevard
- Concept 3 – Grid

Of the three images, which park/open space configuration do you prefer? (Choose 1)

Concept 1 - Consolidated

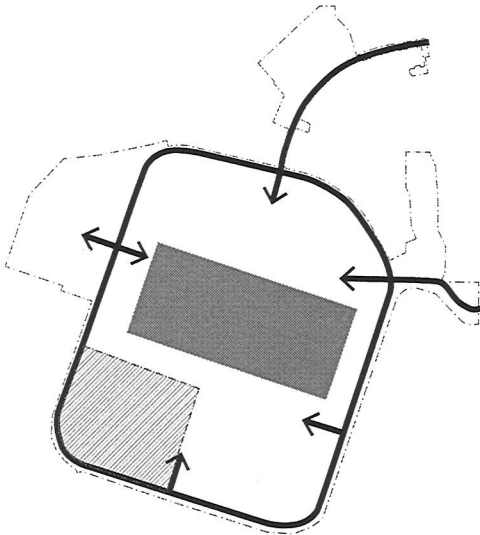

Concept 2 - Distributed

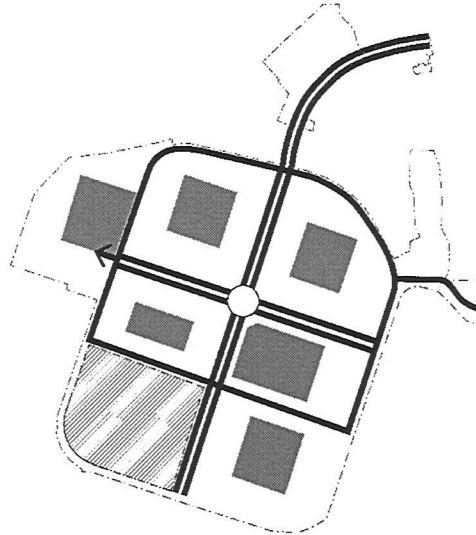

Concept 3 - Combination

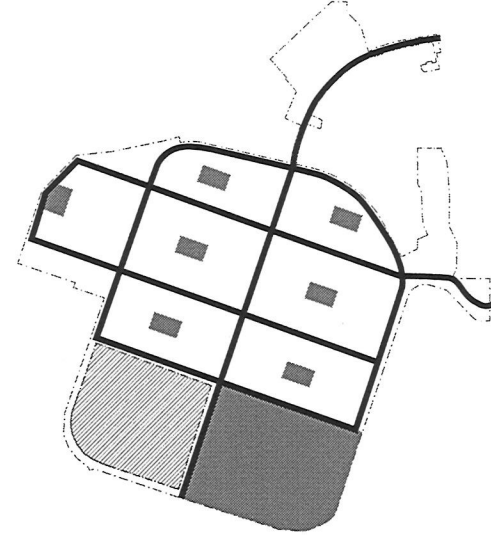

- Concept 1 – Consolidated
- Concept 2 – Distributed
- Concept 3 – Combination



Tell us more about you! What is your affiliation with Costa Mesa?

- I'm a resident
- I'm with an NGO/Non-Profit
- I'm a business owner
- I'm a developer
- I'm a property owner
- Other

For active open space areas, what types of facilities do you prefer? (Choose 2)

- Soccer fields
- Baseball fields
- Playgrounds
- Recreation Center
- Trails

What alternative modes of transportation do you prefer? (Choose 2)

- Walking
- Biking
- Golf Cart (or Neighborhood Electric Vehicle)
- Scooter
- Transit

Of the three images, which circulation concept do you prefer? (Choose 1)

Concept 1 - Loop

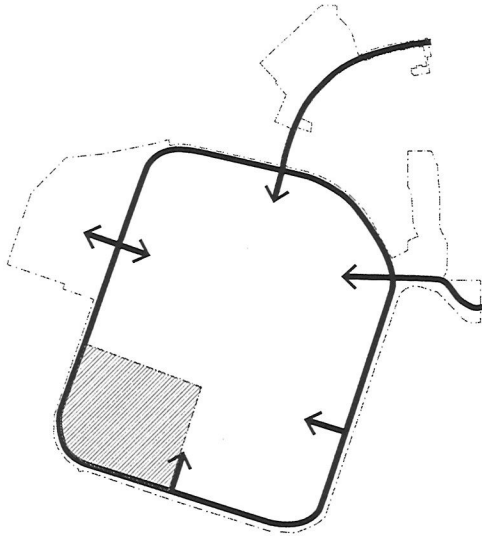

Concept 2 - Boulevard

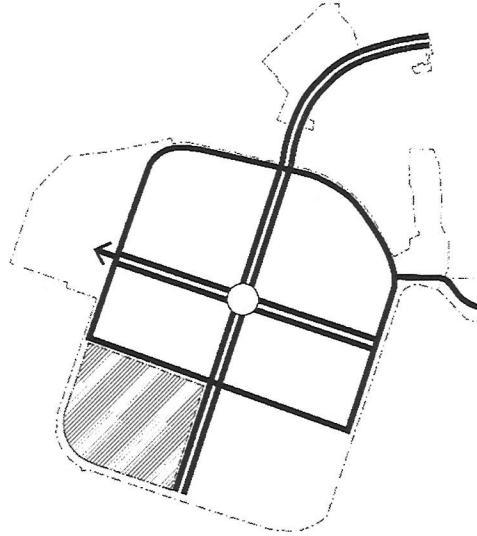

Concept 3 - Grid

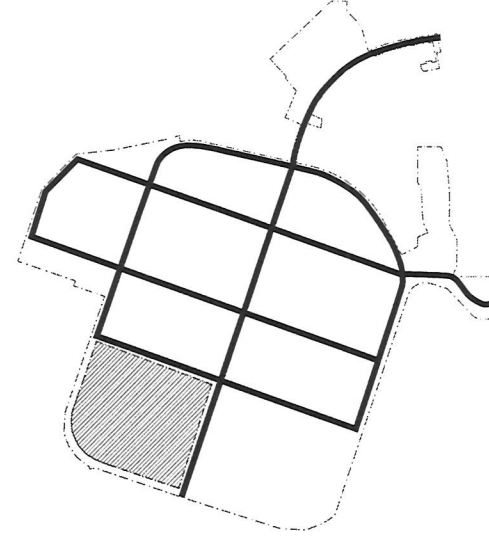

- Concept 1 – Loop
- Concept 2 – Boulevard
- Concept 3 – Grid

Of the three images, which park/open space configuration do you prefer? (Choose 1)

Concept 1 - Consolidated

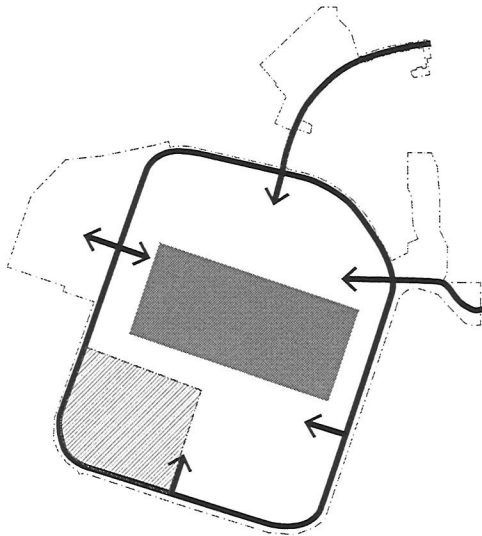

Concept 2 - Distributed

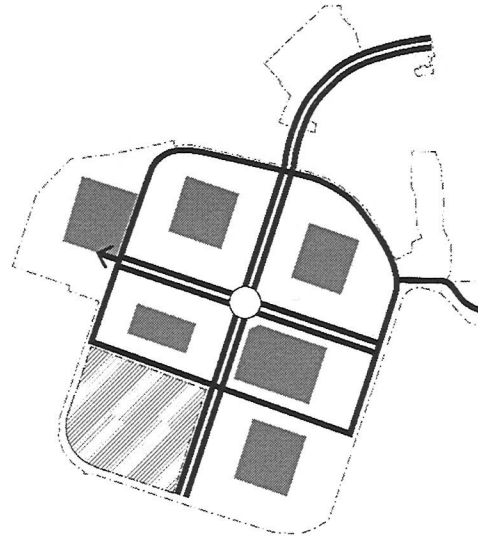

Concept 3 - Combination

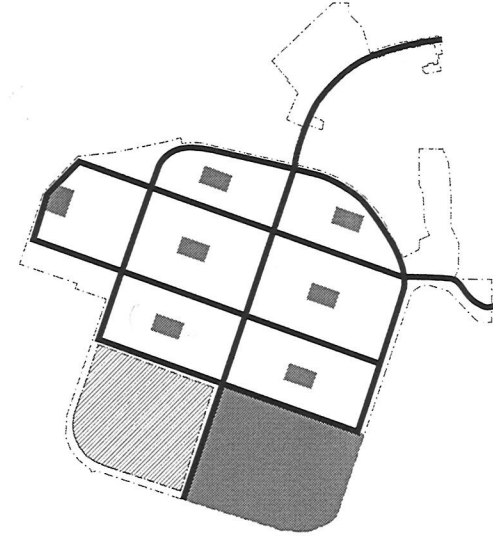

- Concept 1 – Consolidated
- Concept 2 – Distributed
- Concept 3 – Combination

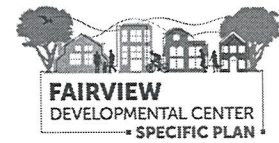

Tell us more about you! What is your affiliation with Costa Mesa?

- I'm a resident
- I'm with an NGO/Non-Profit
- I'm a business owner
- I'm a developer
- I'm a property owner
- Other

For active open space areas, what types of facilities do you prefer? (Choose 2)

- Soccer fields
- Baseball fields
- Playgrounds
- Recreation Center
- Trails

What alternative modes of transportation do you prefer? (Choose 2)

- Walking
- Biking
- Golf Cart (or Neighborhood Electric Vehicle)
- Scooter
- Transit

Of the three images, which circulation concept do you prefer? (Choose 1)

Concept 1 - Loop

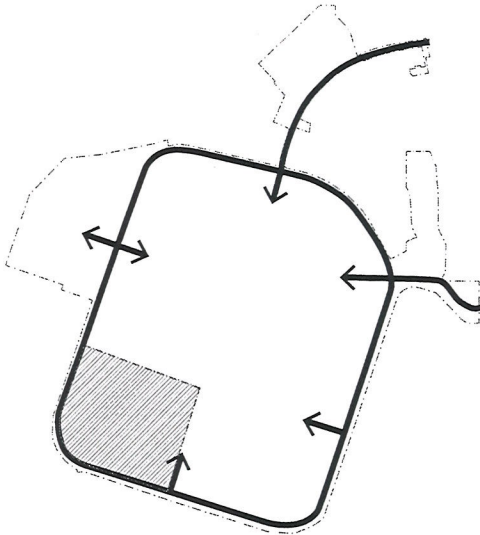

Concept 2 - Boulevard

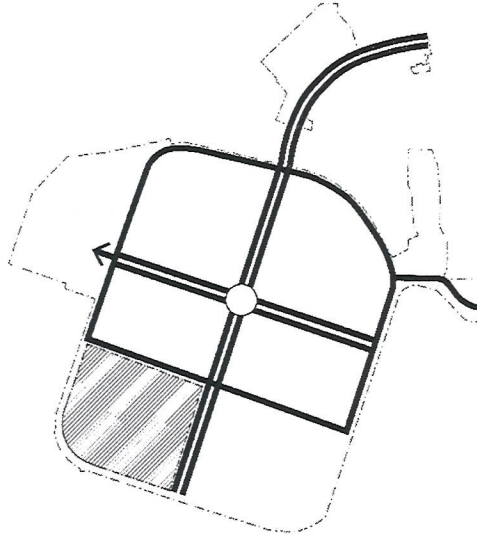

Concept 3 - Grid

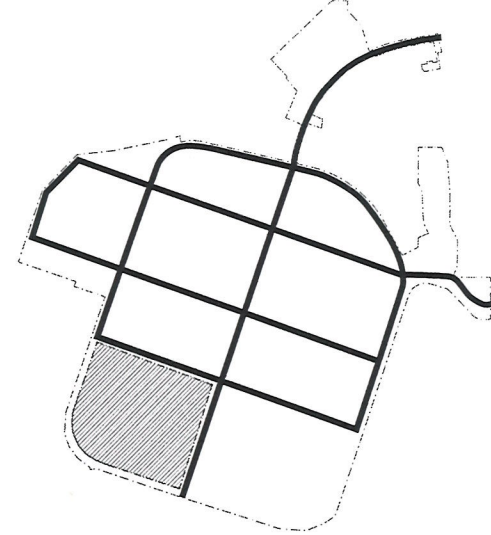

- Concept 1 – Loop
- Concept 2 – Boulevard
- Concept 3 – Grid

Of the three images, which park/open space configuration do you prefer? (Choose 1)

Concept 1 - Consolidated

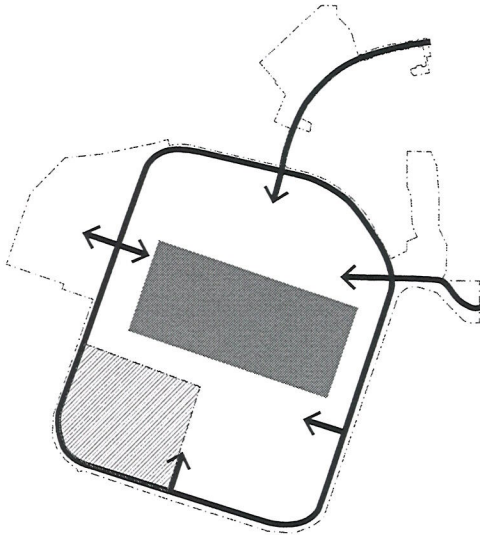

Concept 2 - Distributed

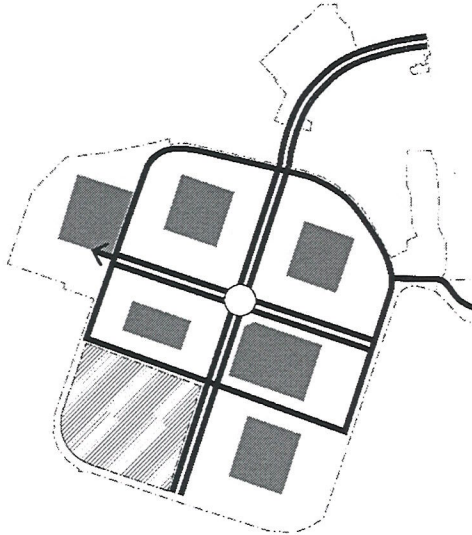

Concept 3 - Combination

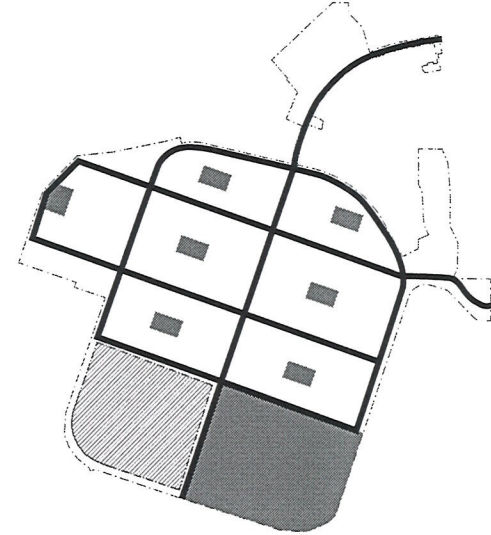

- Concept 1 – Consolidated
- Concept 2 – Distributed
- Concept 3 – Combination



Tell us more about you! What is your affiliation with Costa Mesa?

- I'm a resident
- I'm with an NGO/Non-Profit
- I'm a business owner
- I'm a developer
- I'm a property owner
- Other

For active open space areas, what types of facilities do you prefer? (Choose 2)

- Soccer fields
- Baseball fields
- Playgrounds
- Recreation Center
- Trails

What alternative modes of transportation do you prefer? (Choose 2)

- Walking
- Biking
- Golf Cart (or Neighborhood Electric Vehicle)
- Scooter
- Transit

Of the three images, which circulation concept do you prefer? (Choose 1)

Concept 1 - Loop

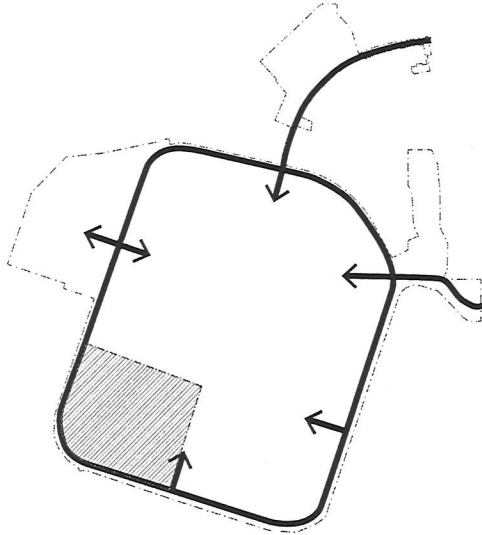

Concept 2 - Boulevard

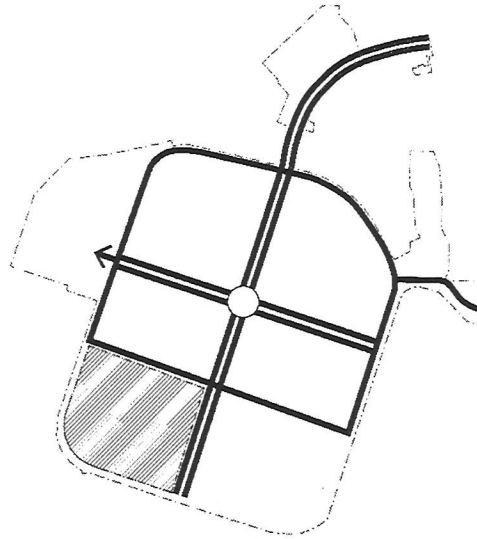

Concept 3 - Grid

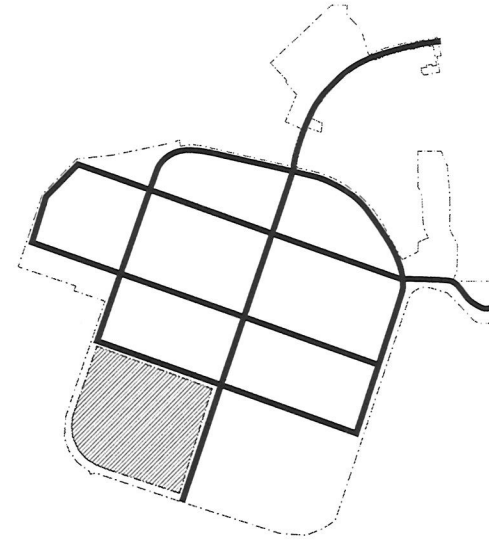

- Concept 1 – Loop
- Concept 2 – Boulevard
- Concept 3 – Grid

Of the three images, which park/open space configuration do you prefer? (Choose 1)

Concept 1 - Consolidated

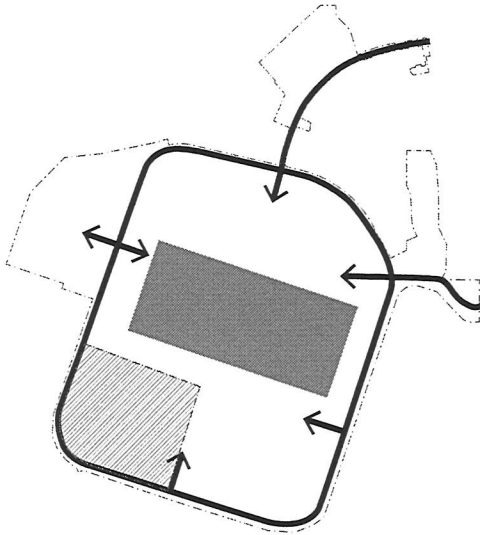

Concept 2 - Distributed

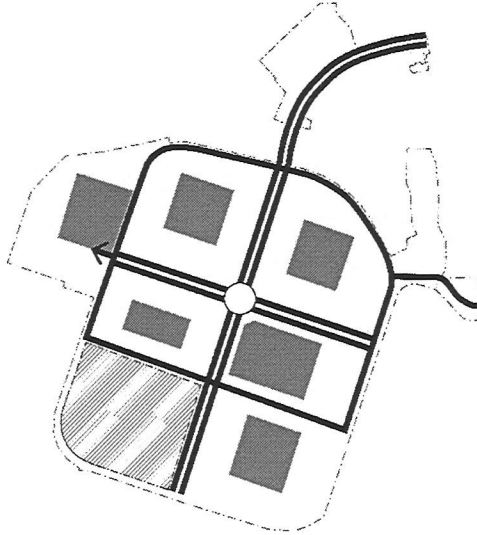

Concept 3 - Combination

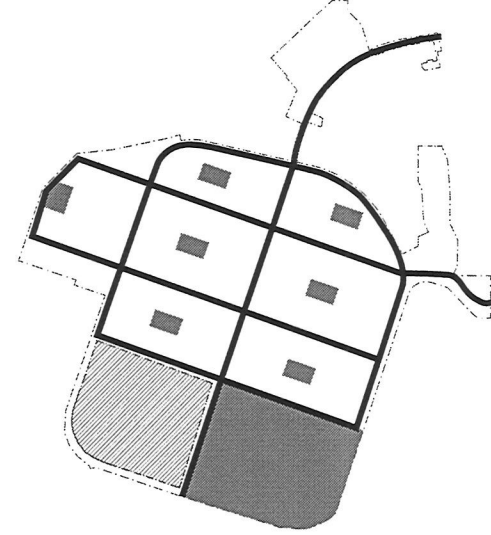

- Concept 1 – Consolidated
- Concept 2 – Distributed
- Concept 3 – Combination



Tell us more about you! What is your affiliation with Costa Mesa?

- I'm a resident
- I'm with an NGO/Non-Profit
- I'm a business owner
- I'm a developer
- I'm a property owner
- Other

For active open space areas, what types of facilities do you prefer? (Choose 2)

- Soccer fields
- Baseball fields
- Playgrounds
- Recreation Center
- Trails

What alternative modes of transportation do you prefer? (Choose 2)

- Walking
- Biking
- Golf Cart (or Neighborhood Electric Vehicle)
- Scooter
- Transit

Of the three images, which circulation concept do you prefer? (Choose 1)

Concept 1 - Loop

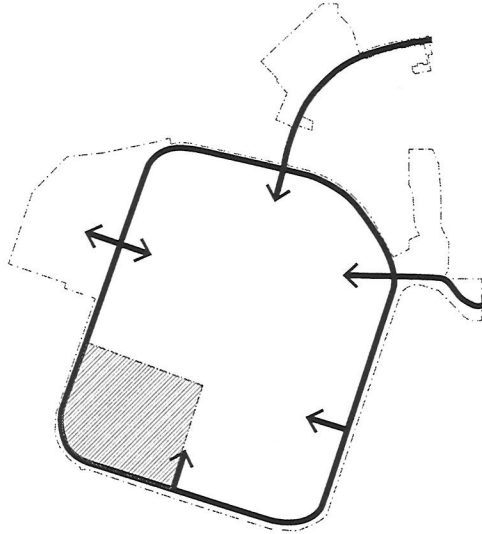

Concept 2 - Boulevard

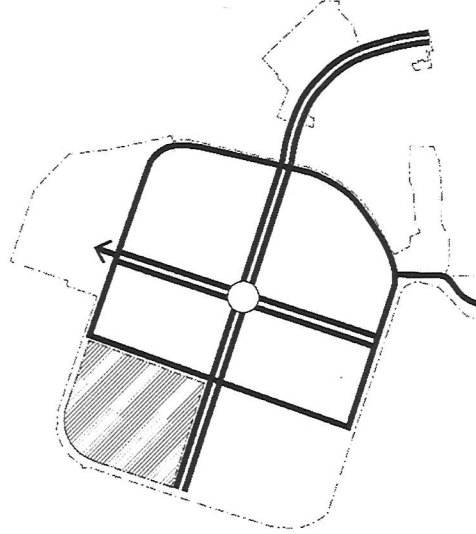

Concept 3 - Grid

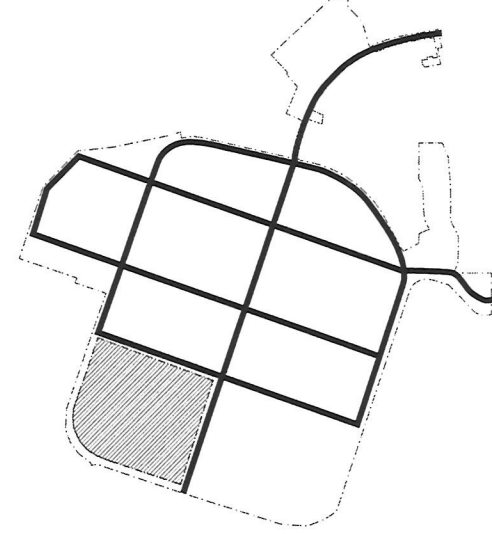

- Concept 1 – Loop
- Concept 2 – Boulevard
- Concept 3 – Grid

Of the three images, which park/open space configuration do you prefer? (Choose 1)

Concept 1 - Consolidated

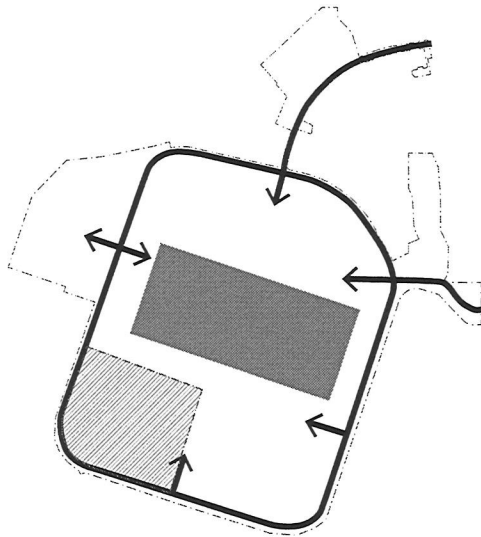

Concept 2 - Distributed

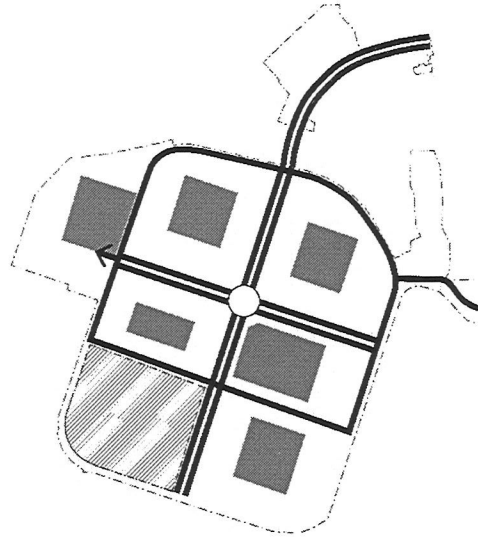

Concept 3 - Combination

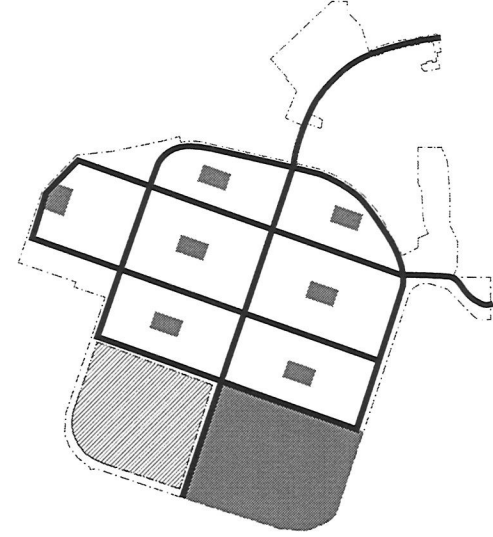

- Concept 1 – Consolidated
- Concept 2 – Distributed
- Concept 3 – Combination



Tell us more about you! What is your affiliation with Costa Mesa?

- I'm a resident
- I'm with an NGO/Non-Profit
- I'm a business owner
- I'm a developer
- I'm a property owner
- Other

For active open space areas, what types of facilities do you prefer? (Choose 2)

- Soccer fields
- Baseball fields
- Playgrounds
- Recreation Center
- Trails

What alternative modes of transportation do you prefer? (Choose 2)

- Walking
- Biking
- Golf Cart (or Neighborhood Electric Vehicle)
- Scooter
- Transit

Of the three images, which circulation concept do you prefer? (Choose 1)

Concept 1 - Loop

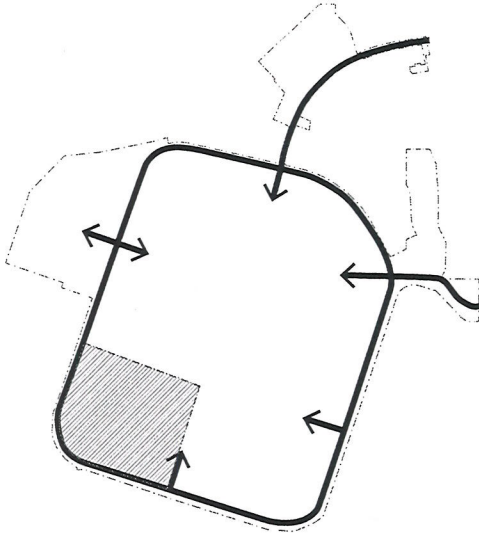

Concept 2 - Boulevard

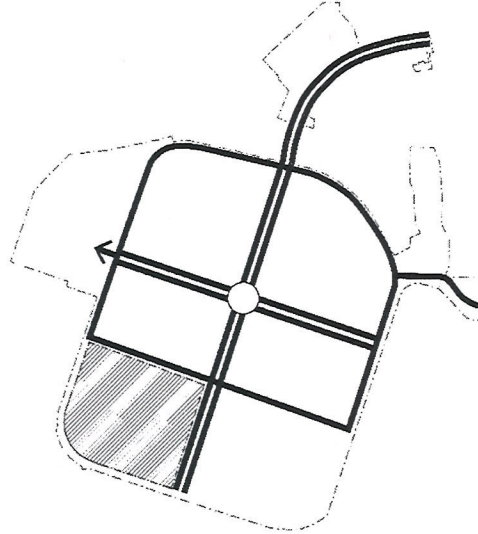

Concept 3 - Grid

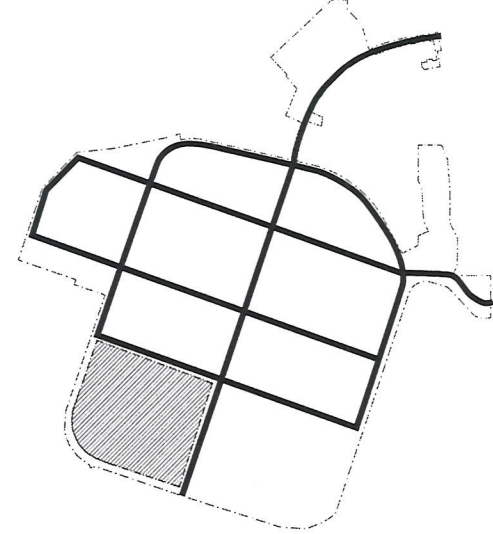

- Concept 1 – Loop
- Concept 2 – Boulevard
- Concept 3 – Grid

Of the three images, which park/open space configuration do you prefer? (Choose 1)

Concept 1 - Consolidated

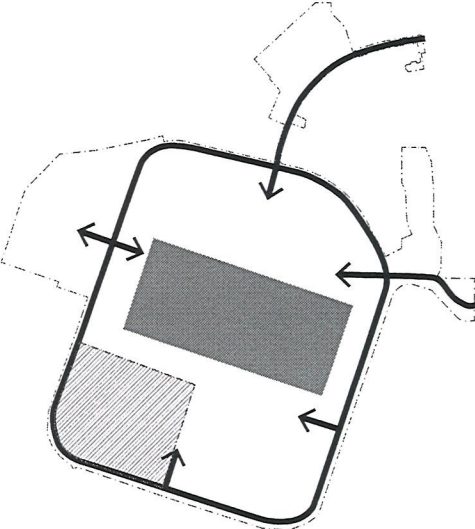

Concept 2 - Distributed

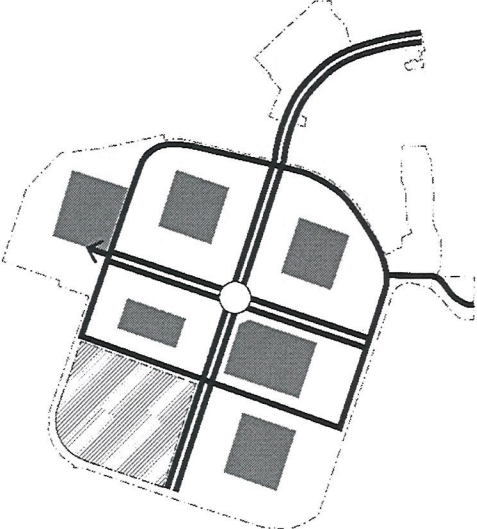

Concept 3 - Combination

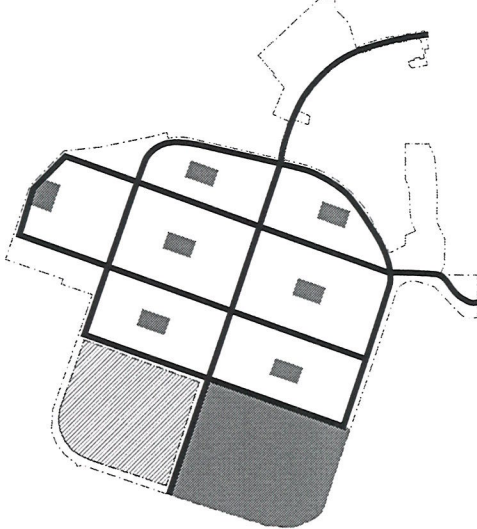

- Concept 1 – Consolidated
- Concept 2 – Distributed
- Concept 3 – Combination



Tell us more about you! What is your affiliation with Costa Mesa?

- I'm a resident
- I'm with an NGO/Non-Profit
- I'm a business owner
- I'm a developer
- I'm a property owner
- Other

For active open space areas, what types of facilities do you prefer? (Choose 2)

- Soccer fields
- Baseball fields *NO LITTLE LEAGUE USE*
- Playgrounds
- Recreation Center
- Trails

What alternative modes of transportation do you prefer? (Choose 2)

- Walking
- Biking
- Golf Cart (or Neighborhood Electric Vehicle)
- Scooter
- Transit

Of the three images, which circulation concept do you prefer? (Choose 1)

Concept 1 - Loop

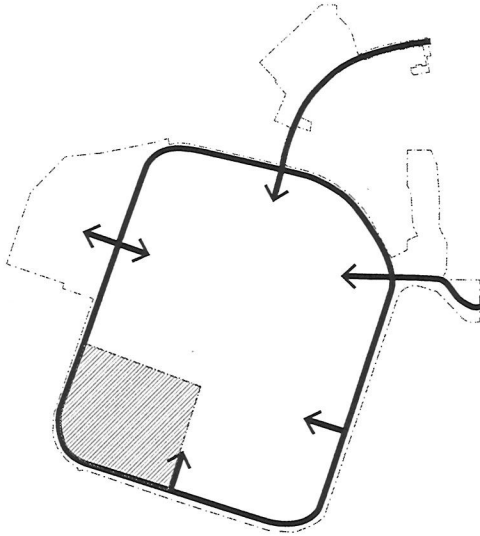

Concept 2 - Boulevard

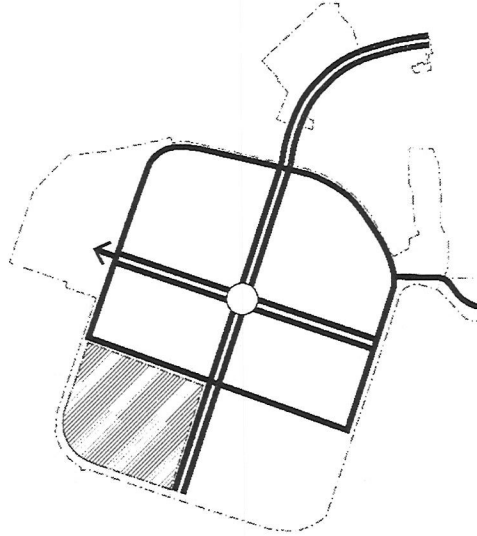

Concept 3 - Grid

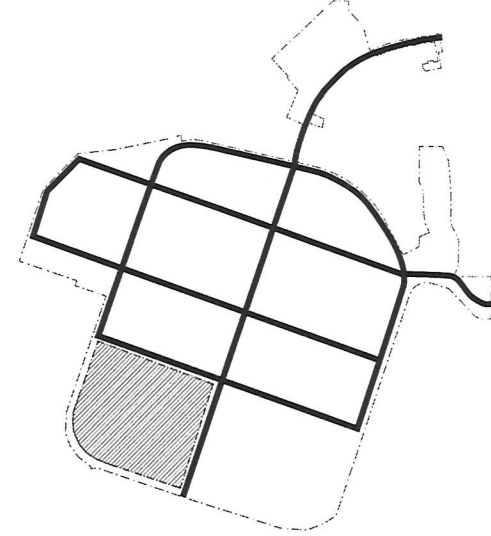

- Concept 1 – Loop
- Concept 2 – Boulevard
- Concept 3 – Grid

Of the three images, which park/open space configuration do you prefer? (Choose 1)

Concept 1 - Consolidated

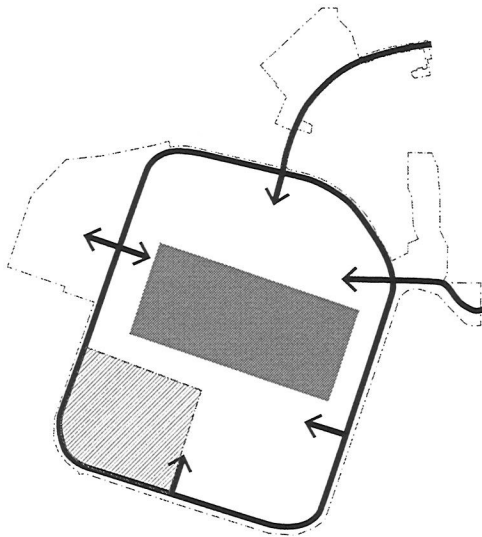

Concept 2 - Distributed

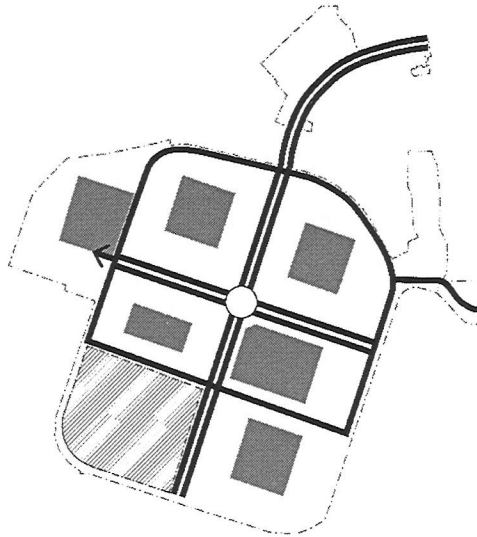

Concept 3 - Combination

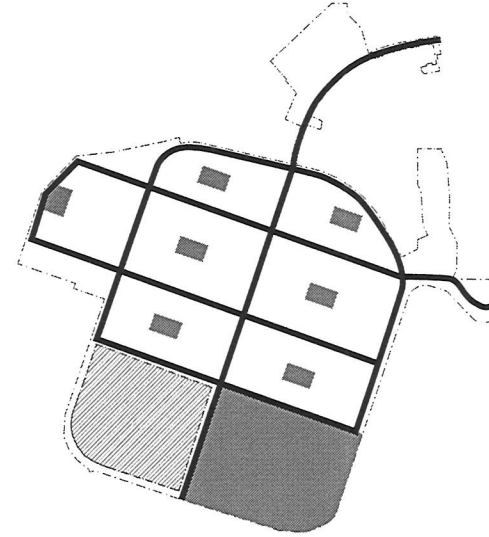

- Concept 1 – Consolidated
- Concept 2 – Distributed
- Concept 3 – Combination



Tell us more about you! What is your affiliation with Costa Mesa?

- I'm a resident
- I'm with an NGO/Non-Profit
- I'm a business owner
- I'm a developer
- I'm a property owner
- Other

For active open space areas, what types of facilities do you prefer? (Choose 2)

- Soccer fields
- Baseball fields *NO LITTLE LEAGUE USE*
- Playgrounds
- Recreation Center
- Trails

What alternative modes of transportation do you prefer? (Choose 2)

- Walking
- Biking
- Golf Cart (or Neighborhood Electric Vehicle)
- Scooter
- Transit

Of the three images, which circulation concept do you prefer? (Choose 1)

Concept 1 - Loop

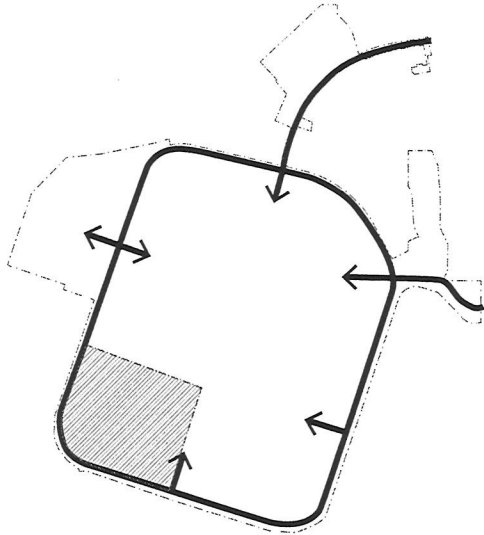

Concept 2 - Boulevard

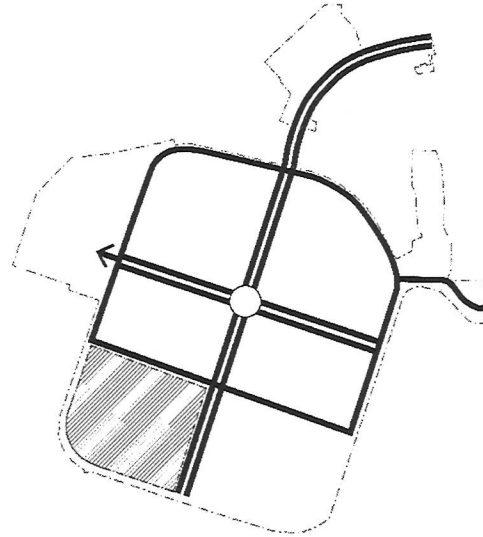

Concept 3 - Grid

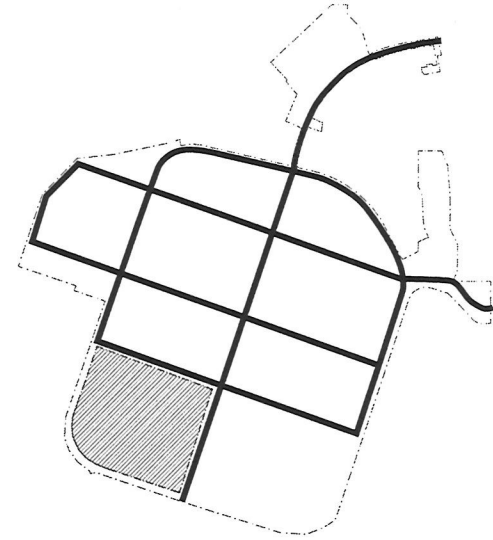

- Concept 1 – Loop
- Concept 2 – Boulevard
- Concept 3 – Grid

Of the three images, which park/open space configuration do you prefer? (Choose 1)

Concept 1 - Consolidated

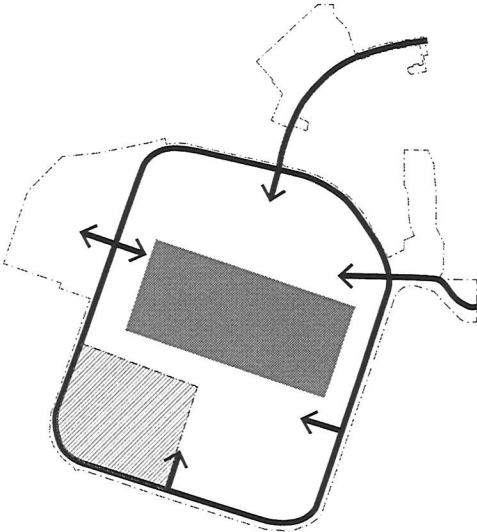

Concept 2 - Distributed

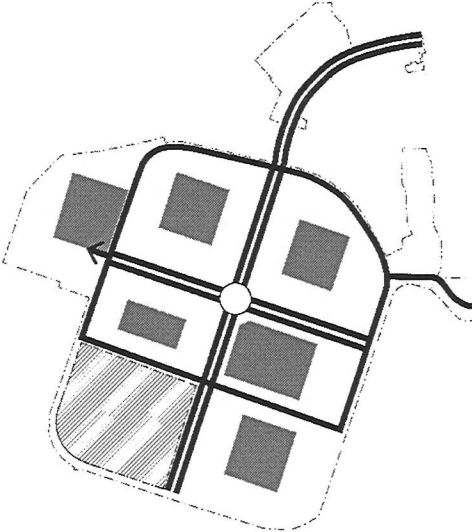

Concept 3 - Combination

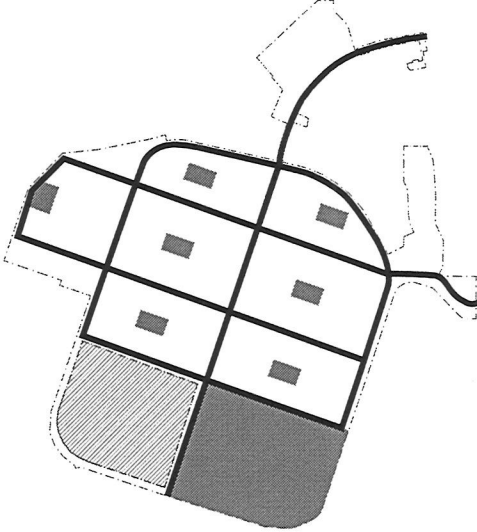

- Concept 1 – Consolidated
- Concept 2 – Distributed
- Concept 3 – Combination



Tell us more about you! What is your affiliation with Costa Mesa?

- I'm a resident
- I'm with an NGO/Non-Profit
- I'm a business owner
- I'm a developer
- I'm a property owner
- Other

For active open space areas, what types of facilities do you prefer? (Choose 2)

- Soccer fields
- Baseball fields
- Playgrounds
- Recreation Center
- Trails

What alternative modes of transportation do you prefer? (Choose 2)

- Walking
- Biking
- Golf Cart (or Neighborhood Electric Vehicle)
- Scooter
- Transit

Of the three images, which circulation concept do you prefer? (Choose 1)

Concept 1 - Loop

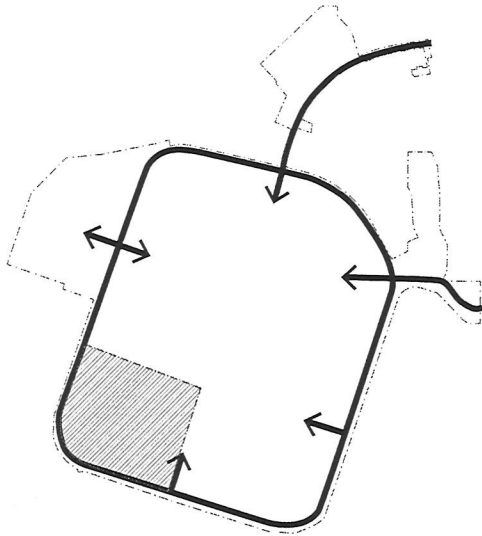

Concept 2 - Boulevard

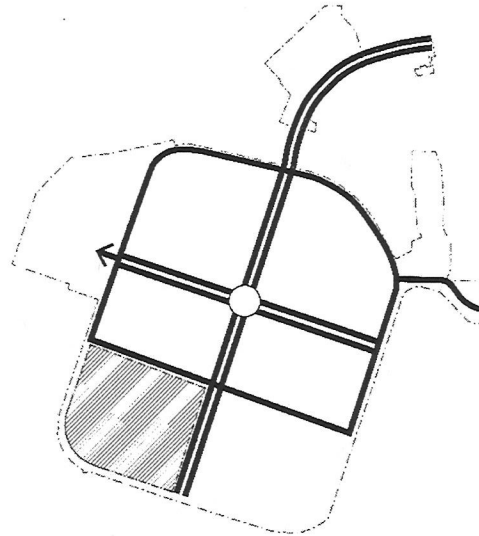

Concept 3 - Grid

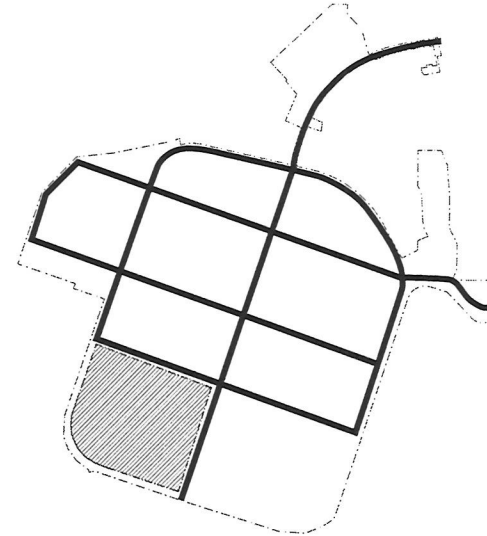

- Concept 1 – Loop
- Concept 2 – Boulevard
- Concept 3 – Grid

Of the three images, which park/open space configuration do you prefer? (Choose 1)

Concept 1 - Consolidated

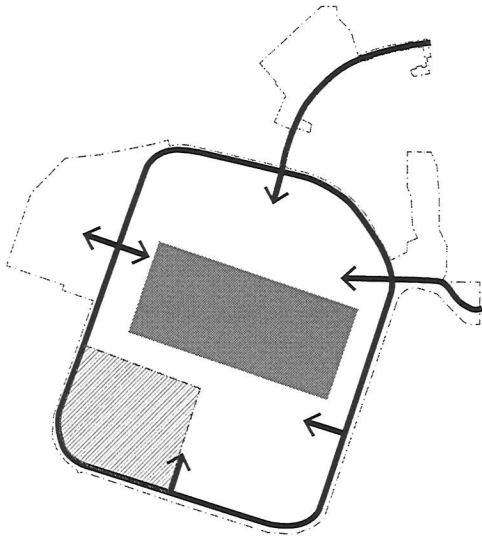

Concept 2 - Distributed

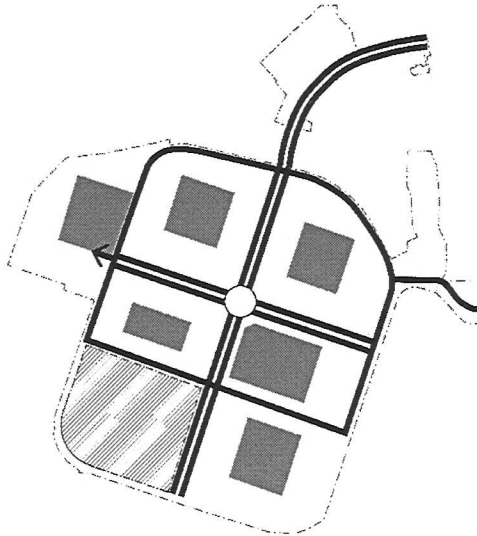

Concept 3 - Combination

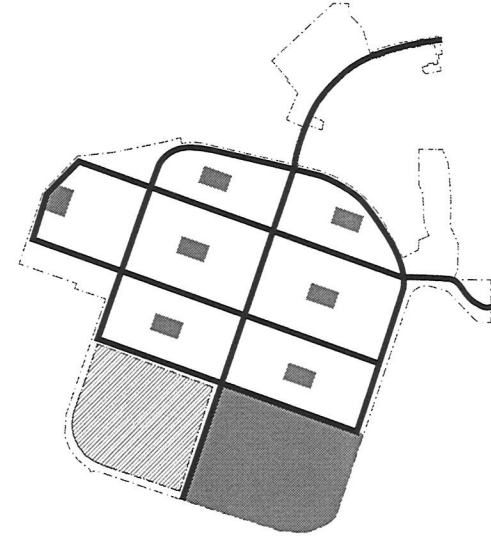

- Concept 1 – Consolidated
- Concept 2 – Distributed
- Concept 3 – Combination



Tell us more about you! What is your affiliation with Costa Mesa?

- I'm a resident
- I'm with an NGO/Non-Profit
- I'm a business owner
- I'm a developer
- I'm a property owner
- Other

For active open space areas, what types of facilities do you prefer? (Choose 2)

- Soccer fields
- Baseball fields
- Playgrounds
- Recreation Center
- Trails

What alternative modes of transportation do you prefer? (Choose 2)

- Walking
- Biking
- Golf Cart (or Neighborhood Electric Vehicle)
- Scooter
- Transit

Of the three images, which circulation concept do you prefer? (Choose 1)

Concept 1 - Loop

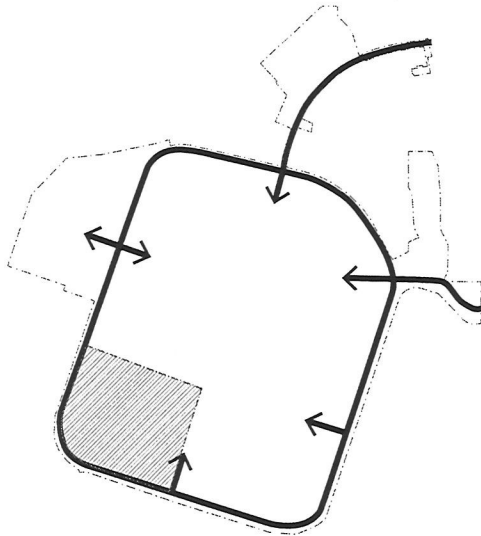

Concept 2 - Boulevard

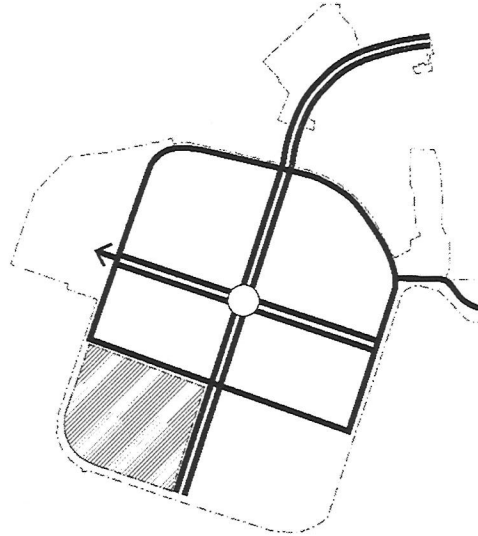

Concept 3 - Grid

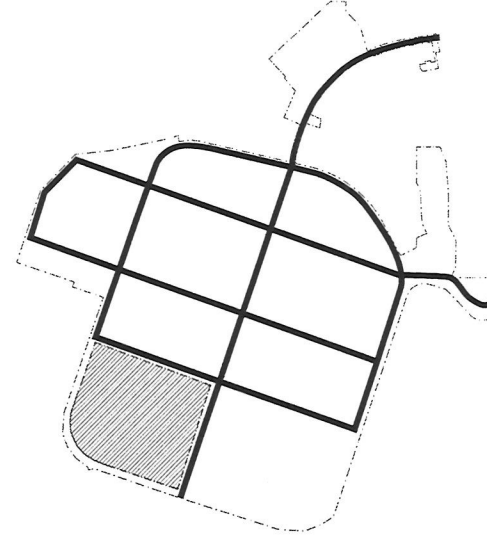

- Concept 1 – Loop
- Concept 2 – Boulevard
- Concept 3 – Grid

the ~~worst~~ one that reduces the amount of space given to streets/parking

Of the three images, which park/open space configuration do you prefer? (Choose 1)

Concept 1 - Consolidated

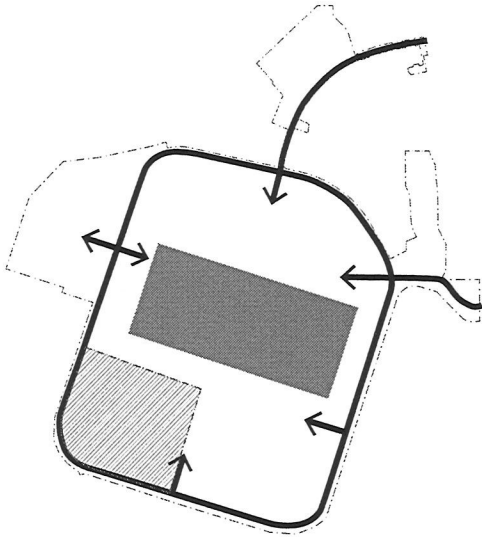

Concept 2 - Distributed

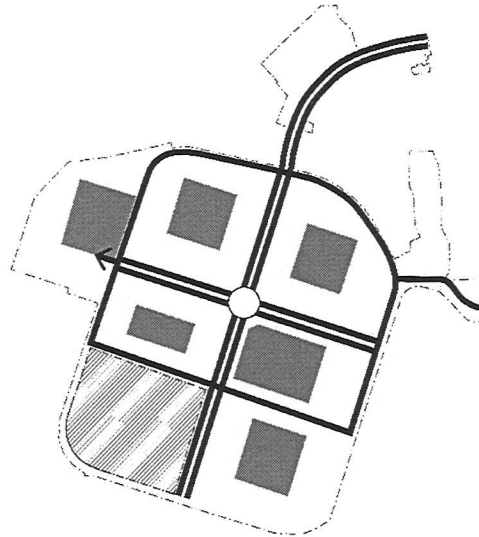

Concept 3 - Combination

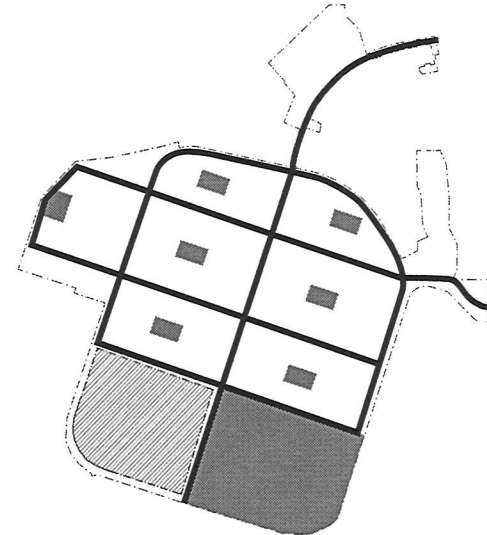

- Concept 1 – Consolidated
- Concept 2 – Distributed
- Concept 3 – Combination



Tell us more about you! What is your affiliation with Costa Mesa?

- I'm a resident
- I'm with an NGO/Non-Profit
- I'm a business owner
- I'm a developer
- I'm a property owner
- Other

For active open space areas, what types of facilities do you prefer? (Choose 2)

- Soccer fields
- Baseball fields
- Playgrounds
- Recreation Center
- Trails

What alternative modes of transportation do you prefer? (Choose 2)

- Walking
- Biking
- Golf Cart (or Neighborhood Electric Vehicle)
- Scooter
- Transit

Of the three images, which circulation concept do you prefer? (Choose 1)

Concept 1 - Loop

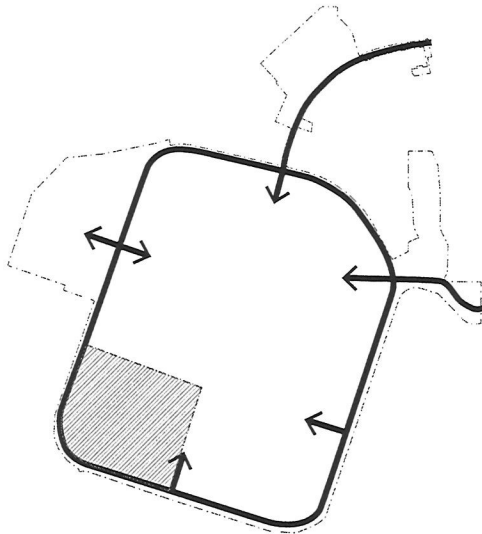

Concept 2 - Boulevard

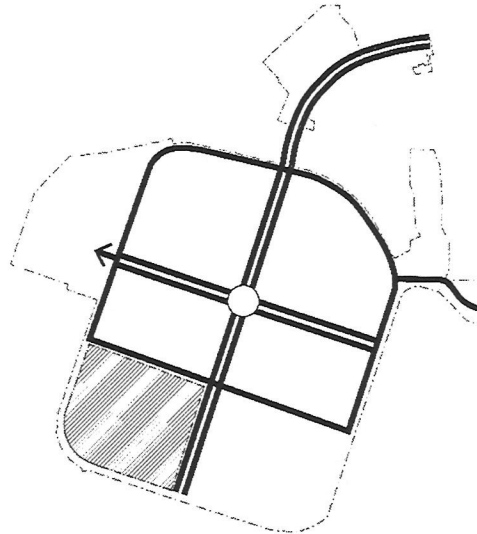

Concept 3 - Grid

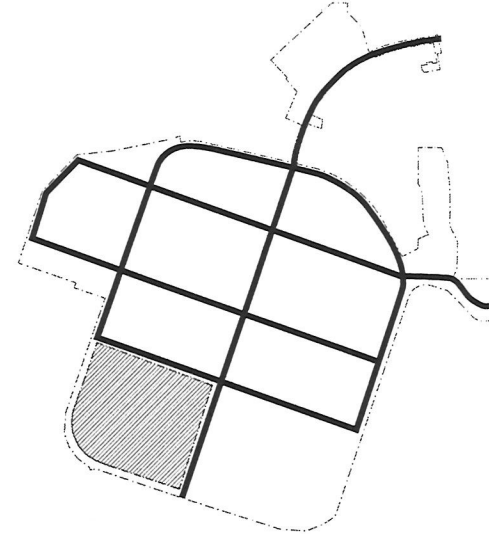

- Concept 1 – Loop
- Concept 2 – Boulevard
- Concept 3 – Grid

Of the three images, which park/open space configuration do you prefer? (Choose 1)

Concept 1 - Consolidated

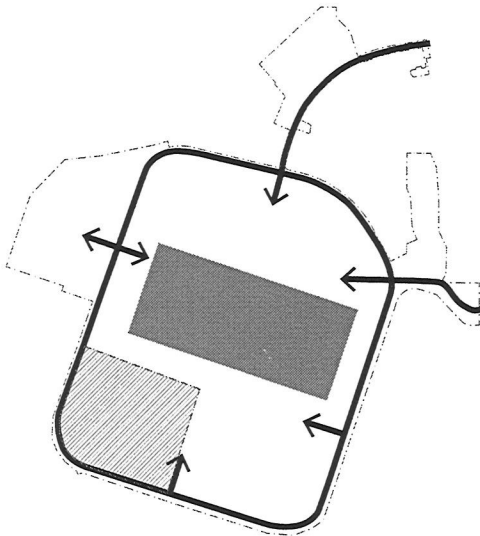

Concept 2 - Distributed

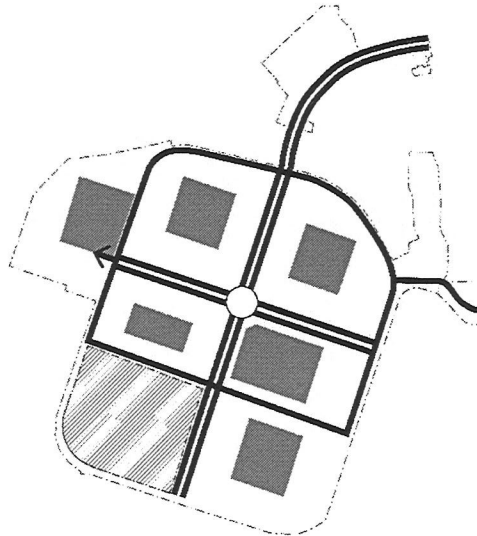

Concept 3 - Combination

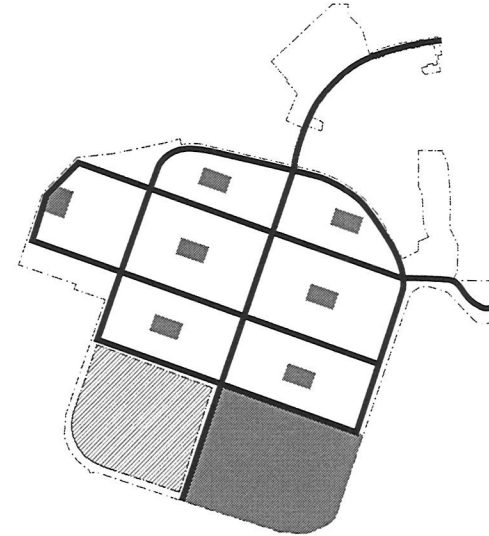

- Concept 1 – Consolidated
- Concept 2 – Distributed
- Concept 3 – Combination

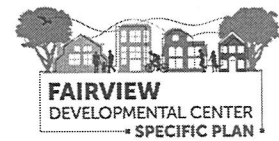

Tell us more about you! What is your affiliation with Costa Mesa?

- I'm a resident
- I'm with an NGO/Non-Profit
- I'm a business owner
- I'm a developer
- I'm a property owner
- Other

For active open space areas, what types of facilities do you prefer? (Choose 2)

- Soccer fields
- Baseball fields
- Playgrounds
- Recreation Center
- Trails

What alternative modes of transportation do you prefer? (Choose 2)

- Walking
- Biking
- Golf Cart (or Neighborhood Electric Vehicle)
- Scooter
- Transit

Of the three images, which circulation concept do you prefer? (Choose 1)

Concept 1 - Loop

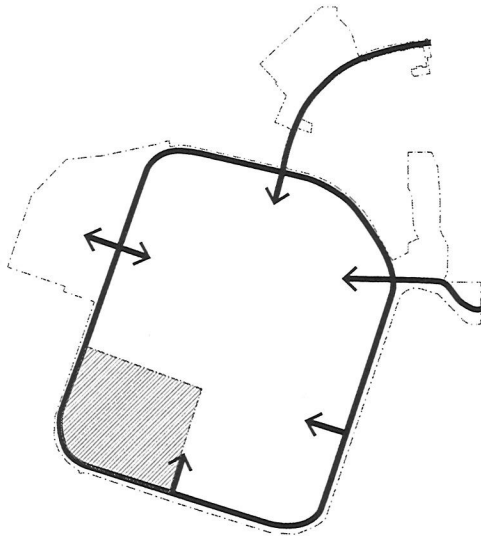

Concept 2 - Boulevard

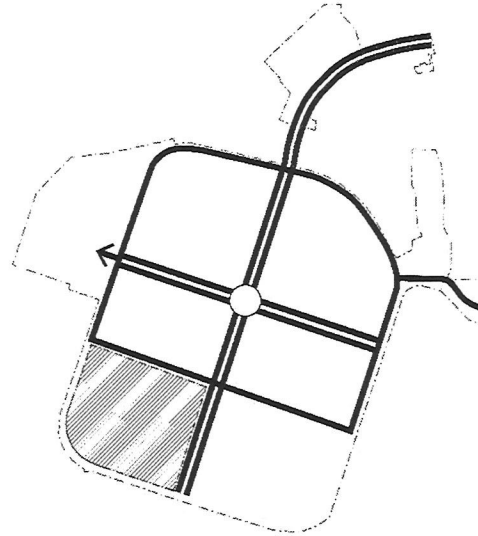

Concept 3 - Grid

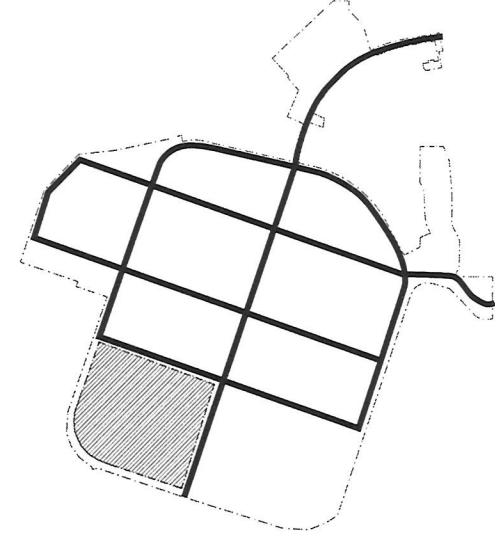

- Concept 1 – Loop
- Concept 2 – Boulevard
- Concept 3 – Grid

Of the three images, which park/open space configuration do you prefer? (Choose 1)

Concept 1 - Consolidated

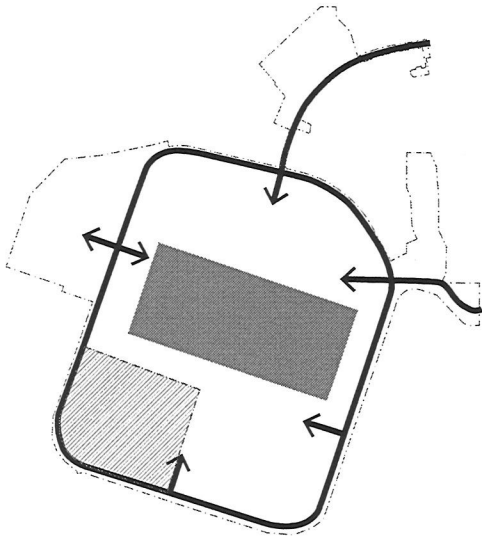

Concept 2 - Distributed

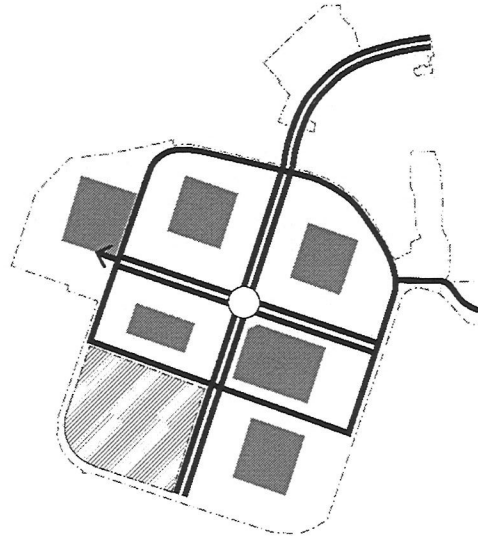

Concept 3 - Combination

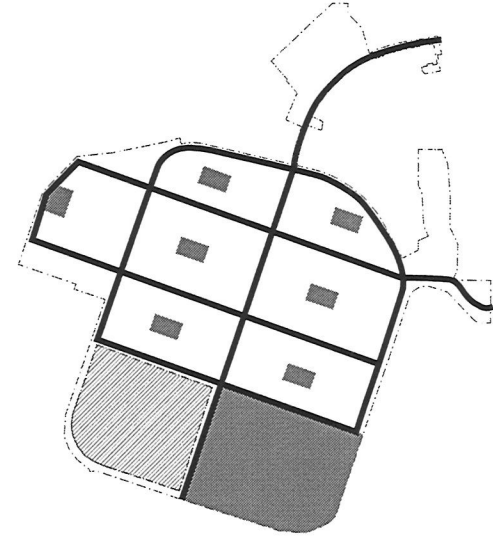

- Concept 1 – Consolidated
- Concept 2 – Distributed
- Concept 3 – Combination



Tell us more about you! What is your affiliation with Costa Mesa?

- I'm a resident
- I'm with an NGO/Non-Profit
- I'm a business owner
- I'm a developer
- I'm a property owner
- Other

For active open space areas, what types of facilities do you prefer? (Choose 2)

- Soccer fields
- Baseball fields
- Playgrounds
- Recreation Center
- Trails

What alternative modes of transportation do you prefer? (Choose 2)

- Walking
- Biking
- Golf Cart (or Neighborhood Electric Vehicle)
- Scooter
- Transit

Of the three images, which circulation concept do you prefer? (Choose 1)

Concept 1 - Loop

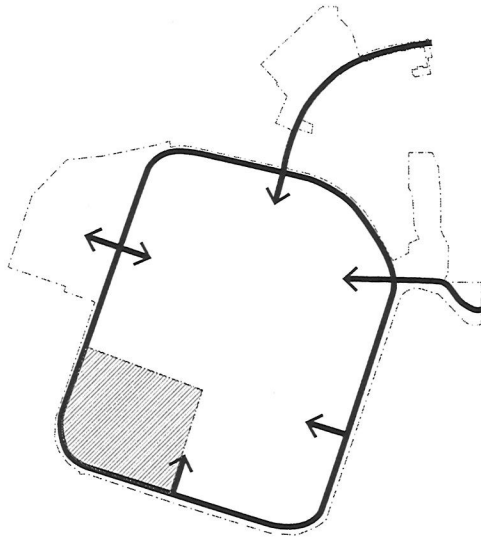

Concept 2 - Boulevard

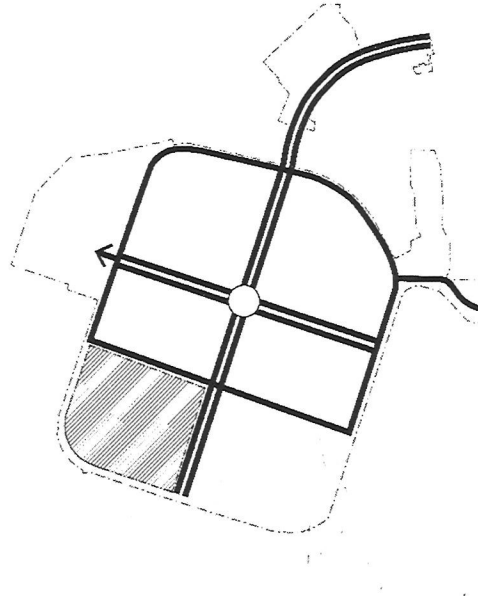

Concept 3 - Grid

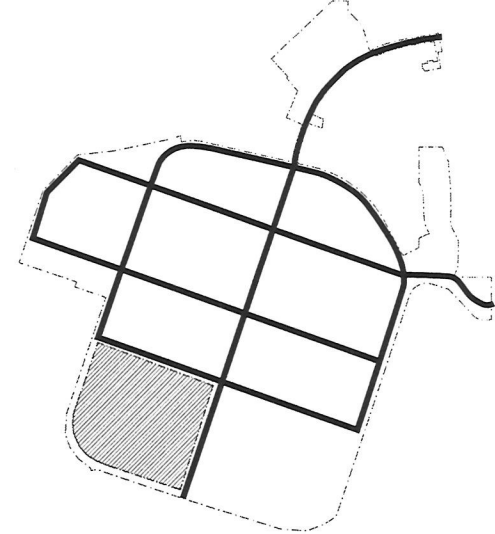

- Concept 1 – Loop
- Concept 2 – Boulevard
- Concept 3 – Grid

Of the three images, which park/open space configuration do you prefer? (Choose 1)

Concept 1 - Consolidated

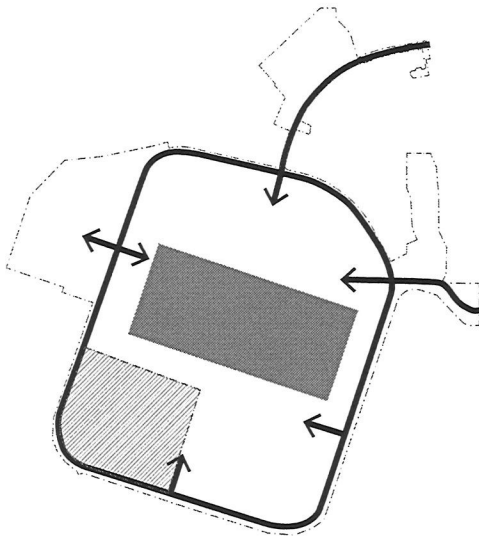

Concept 2 - Distributed

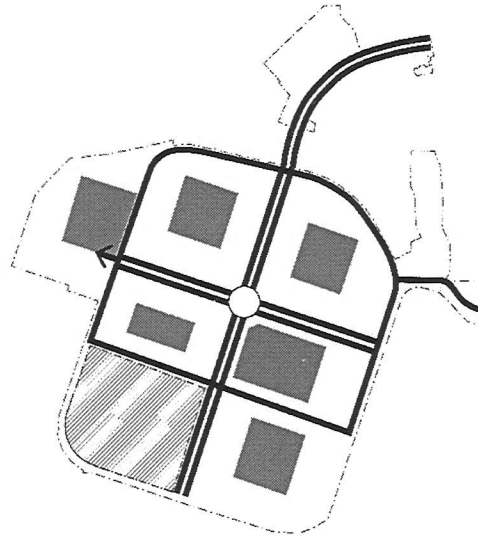

Concept 3 - Combination

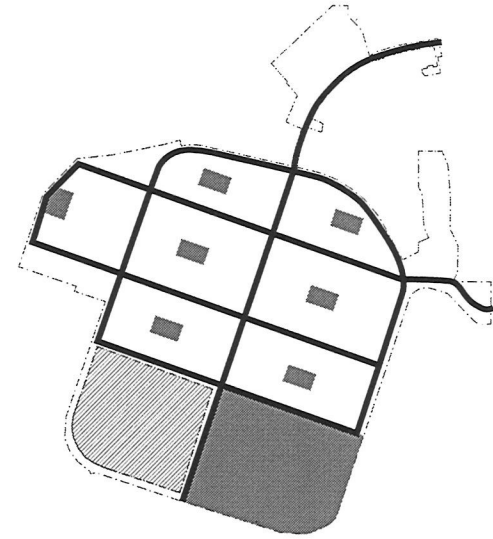

- Concept 1 – Consolidated
- Concept 2 – Distributed
- Concept 3 – Combination

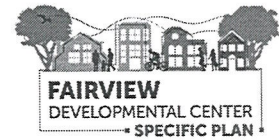

Tell us more about you! What is your affiliation with Costa Mesa?

- I'm a resident
- I'm with an NGO/Non-Profit
- I'm a business owner
- I'm a developer
- I'm a property owner
- Other

For active open space areas, what types of facilities do you prefer? (Choose 2)

- Soccer fields
- Baseball fields
- Playgrounds
- Recreation Center
- Trails

What alternative modes of transportation do you prefer? (Choose 2)

- Walking
- Biking
- Golf Cart (or Neighborhood Electric Vehicle)
- Scooter
- Transit

Of the three images, which circulation concept do you prefer? (Choose 1)

Concept 1 - Loop

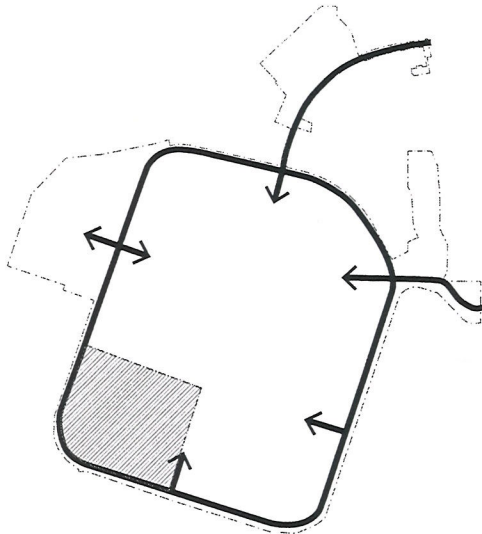

Concept 2 - Boulevard

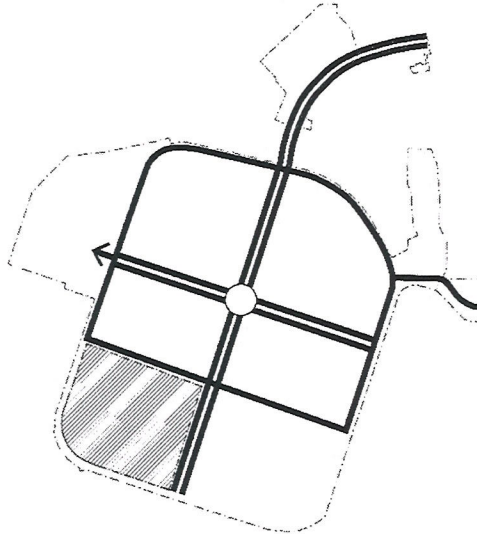

Concept 3 - Grid

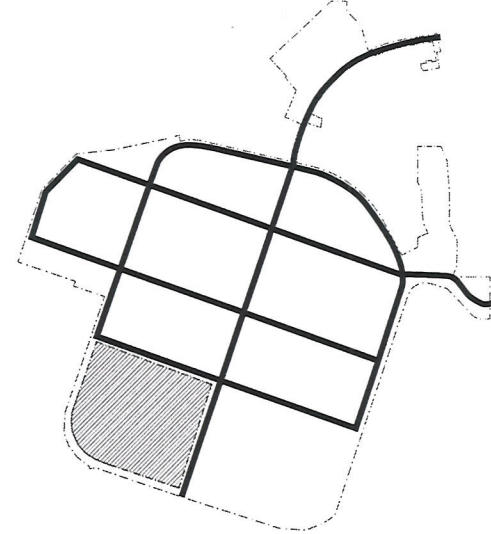

- Concept 1 – Loop
- Concept 2 – Boulevard
- Concept 3 – Grid

Of the three images, which park/open space configuration do you prefer? (Choose 1)

Concept 1 - Consolidated

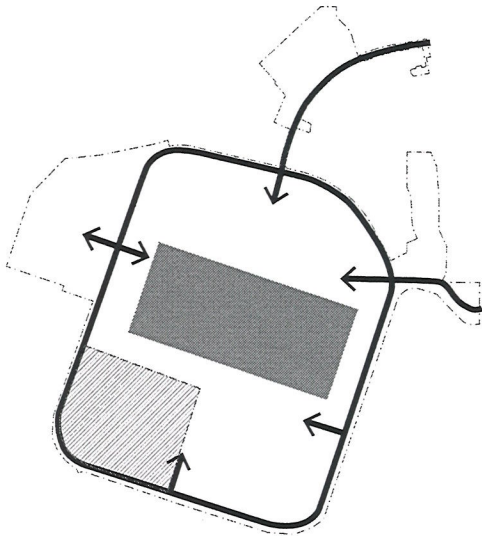

Concept 2 - Distributed

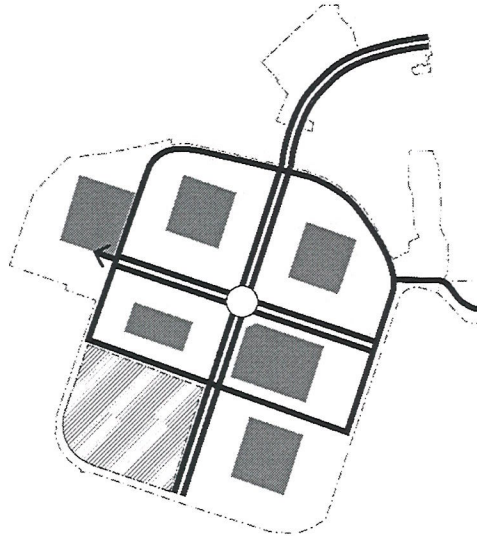

Concept 3 - Combination

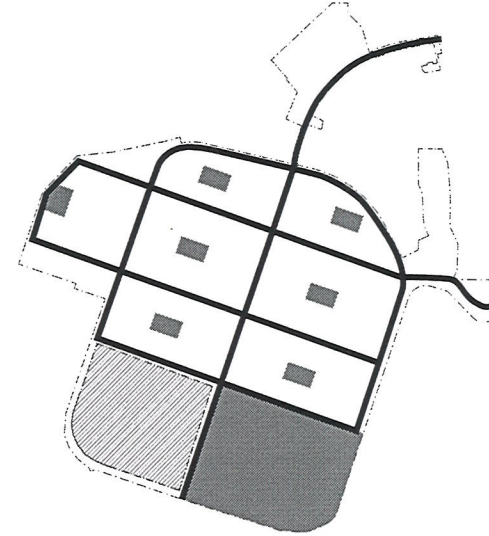

- Concept 1 – Consolidated
- Concept 2 – Distributed
- Concept 3 – Combination



Tell us more about you! What is your affiliation with Costa Mesa?

- I'm a resident
- resident activist*
- I'm with an NGO/Non-Profit
- I'm a business owner
- I'm a developer
- I'm a property owner
- Other

For active open space areas, what types of facilities do you prefer? (Choose 2)

- Soccer fields
- pickleball and tennis*
- Baseball fields
- Playgrounds
- Recreation Center
- Trails

What alternative modes of transportation do you prefer? (Choose 2)

- Walking
- Biking
- Golf Cart (or Neighborhood Electric Vehicle)
- Scooter
- Transit

Of the three images, which circulation concept do you prefer? (Choose 1)

Concept 1 - Loop

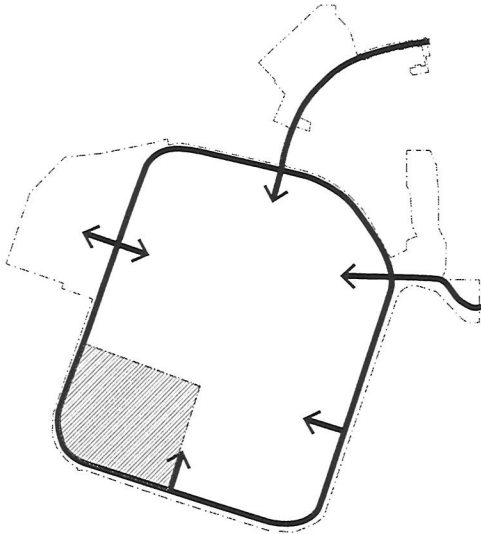

Concept 2 - Boulevard

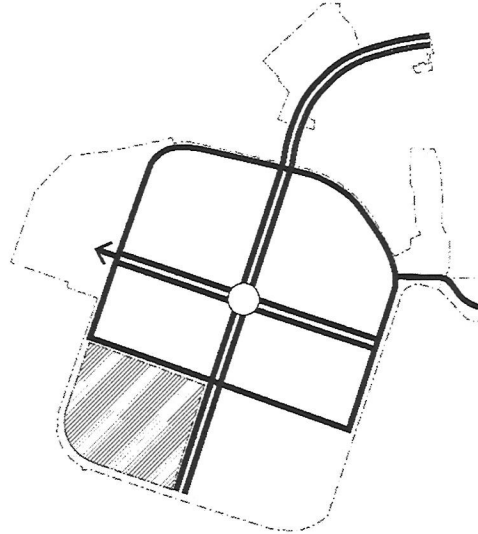

Concept 3 - Grid

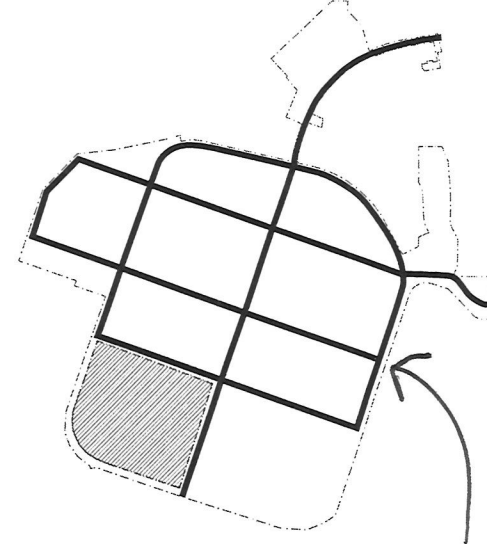

- Concept 1 – Loop
- Concept 2 – Boulevard
- Concept 3 – Grid

THIS WITH
A 15 MPH
SPEED
LIMIT

Of the three images, which park/open space configuration do you prefer? (Choose 1)

Concept 1 - Consolidated

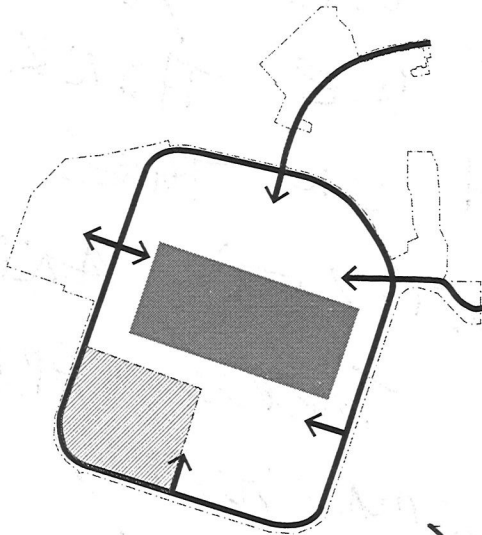

Concept 2 - Distributed

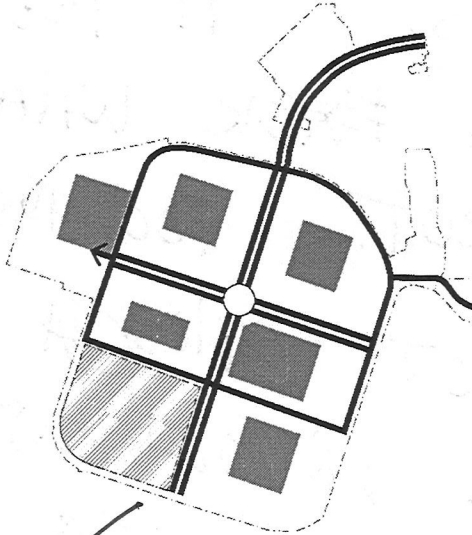

Concept 3 - Combination

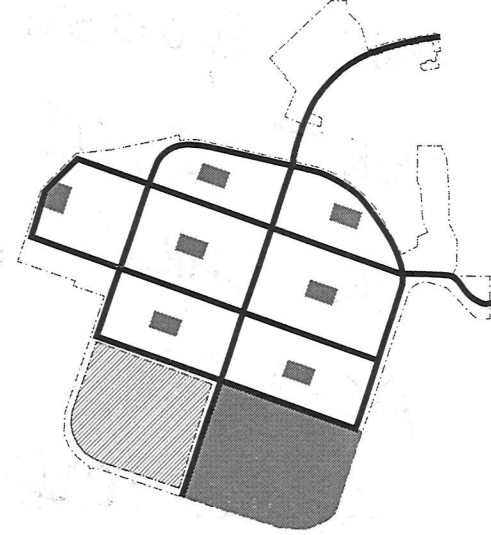

- Concept 1 – Consolidated
- Concept 2 – Distributed
- Concept 3 – Combination

A COMBINATION
OF THE
TWO

↑
CANT PUT IT
THERE – EOC
HAS A ROAD
THRU IT

OVER ↗

THIS WAS A SHITSHOW. YOU ARE NOT
ALLOWING ENOUGH TIME FOR COMMENTS
AND QUESTIONS. IT FEELS LIKE YOU
DON'T GIVE A F*CK WHAT WE THINK
OR CARE ABOUT. TOO MUCH ON THE
AGENDA. NOT ENOUGH CITIZEN AND
STAKEHOLDER INVOLVEMENT. THERE ARE
MANY EXPERTS IN OUR COMMUNITY
WHO COULD WRITE BETTER PRINCIPLES
AND A BETTER VISION STATEMENT THAT
REFLECTS WHAT THE PARTICIPANTS OF
THE FIRST MEETING EXPRESSED.



Tell us more about you! What is your affiliation with Costa Mesa?

- I'm a resident
- I'm with an NGO/Non-Profit
- I'm a business owner
- I'm a developer
- I'm a property owner
- Other

For active open space areas, what types of facilities do you prefer? (Choose 2)

- Soccer fields
- Baseball fields
- Playgrounds
- Recreation Center
- Trails
Pickleball / Tennis

What alternative modes of transportation do you prefer? (Choose 2)

- Walking
- Biking
- Golf Cart (or Neighborhood Electric Vehicle)
- Scooter
- Transit

Of the three images, which circulation concept do you prefer? (Choose 1)

Concept 1 - Loop

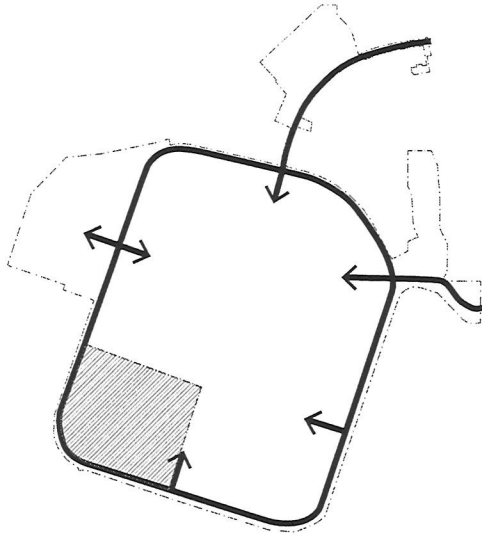

Concept 2 - Boulevard

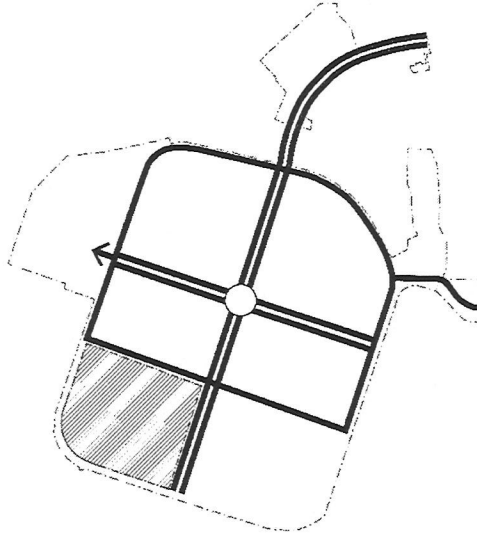

Concept 3 - Grid

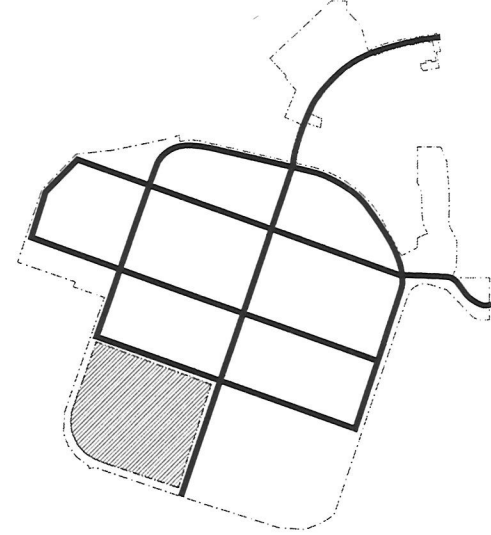

- Concept 1 – Loop
- Concept 2 – Boulevard
- Concept 3 – Grid

Of the three images, which park/open space configuration do you prefer? (Choose 1)

Concept 1 - Consolidated

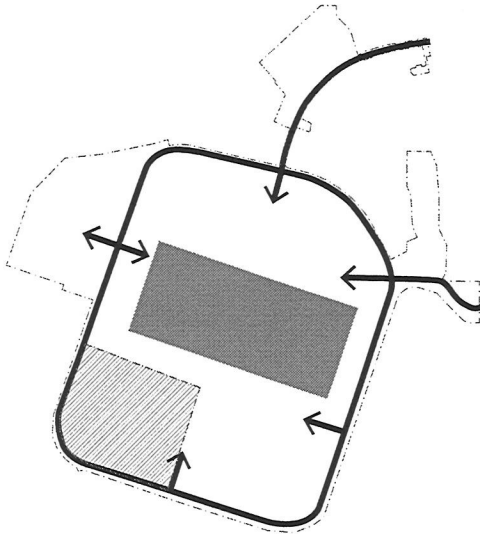

Concept 2 - Distributed

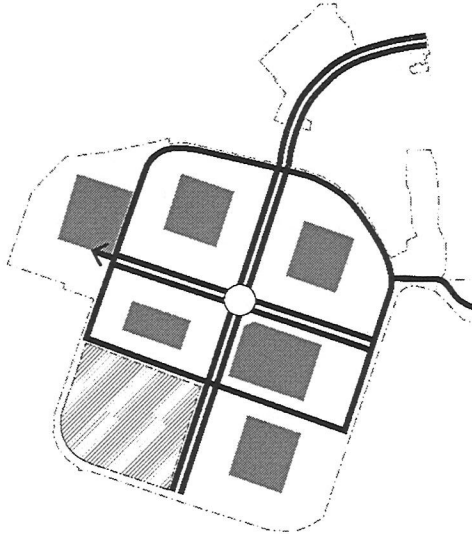

Concept 3 - Combination

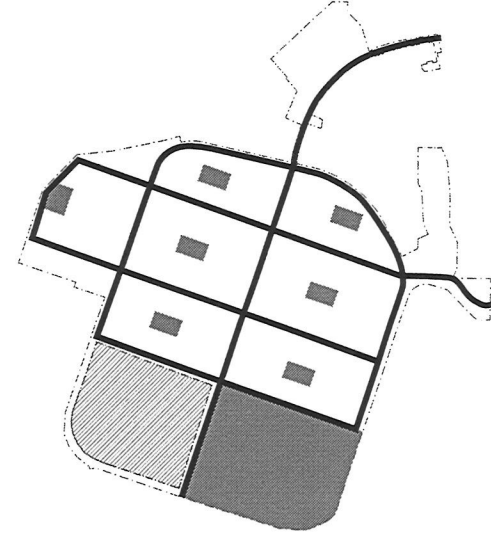

- Concept 1 – Consolidated
- ~~Concept 2 – Distributed~~
- Concept 3 – Combination



Tell us more about you! What is your affiliation with Costa Mesa?

- I'm a resident
- I'm with an NGO/Non-Profit
- I'm a business owner
- I'm a developer
- I'm a property owner
- Other

For active open space areas, what types of facilities do you prefer? (Choose 2)

- Soccer fields
- Baseball fields
- Playgrounds
- Recreation Center
- Trails

What alternative modes of transportation do you prefer? (Choose 2)

- Walking
- Biking
- Golf Cart (or Neighborhood Electric Vehicle)
- Scooter
- Transit

Of the three images, which circulation concept do you prefer? (Choose 1)

Concept 1 - Loop

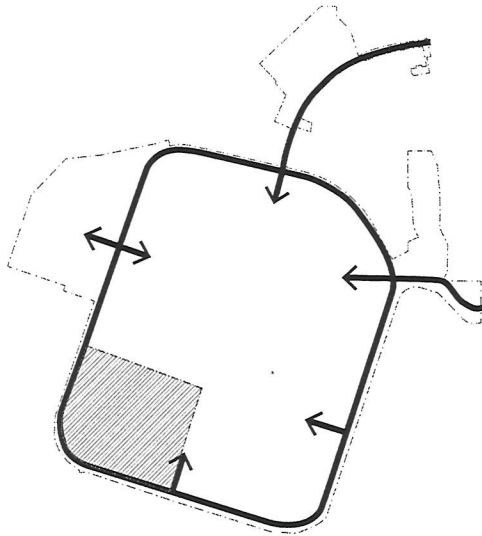

Concept 2 - Boulevard

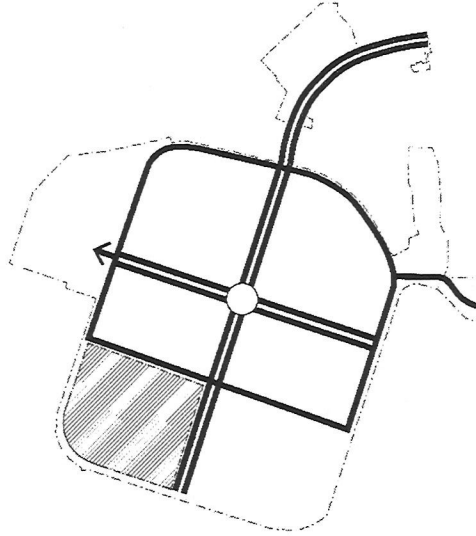

Concept 3 - Grid

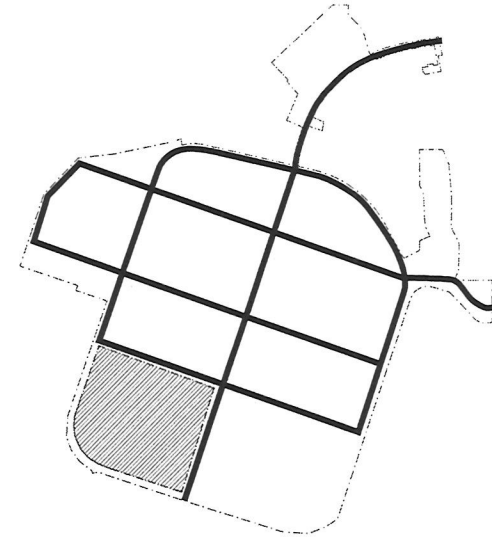

- Concept 1 – Loop
- Concept 2 – Boulevard
- Concept 3 – Grid

Of the three images, which park/open space configuration do you prefer? (Choose 1)

Concept 1 - Consolidated

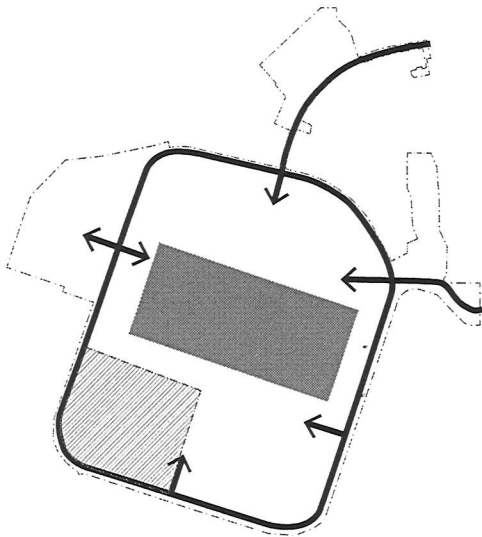

Concept 2 - Distributed

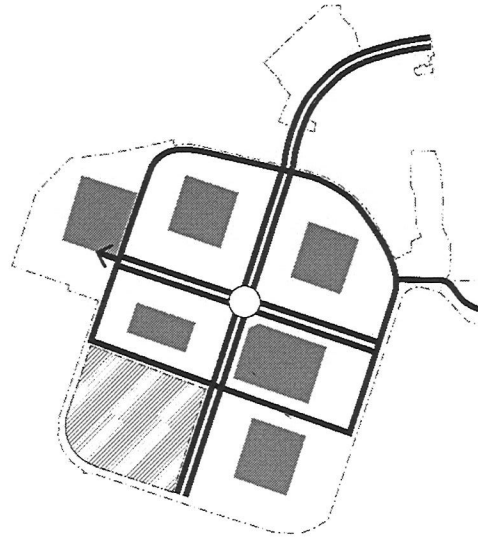

Concept 3 - Combination

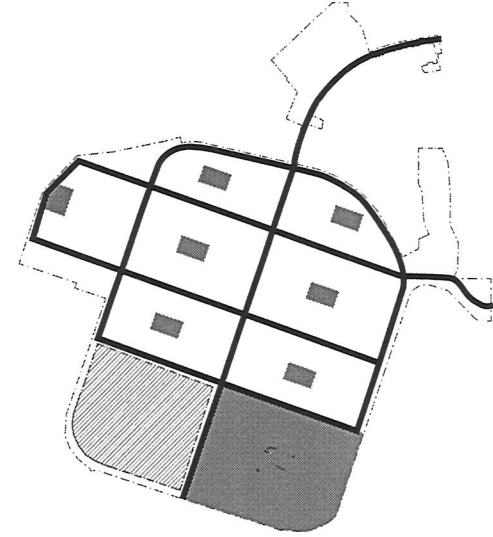

- Concept 1 – Consolidated
- Concept 2 – Distributed
- Concept 3 – Combination



Tell us more about you! What is your affiliation with Costa Mesa?

- I'm a resident
- I'm with an NGO/Non-Profit
- I'm a business owner
- I'm a developer
- I'm a property owner
- Other

For active open space areas, what types of facilities do you prefer? (Choose 2)

- Soccer fields
- Baseball fields
- Playgrounds
- Recreation Center
- Trails

What alternative modes of transportation do you prefer? (Choose 2)

- Walking
- Biking
- Golf Cart (or Neighborhood Electric Vehicle)
- Scooter
- Transit

Of the three images, which circulation concept do you prefer? (Choose 1)

Concept 1 - Loop

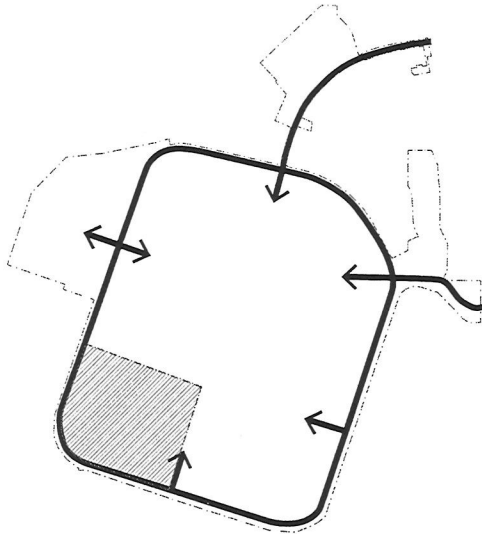

Concept 2 - Boulevard

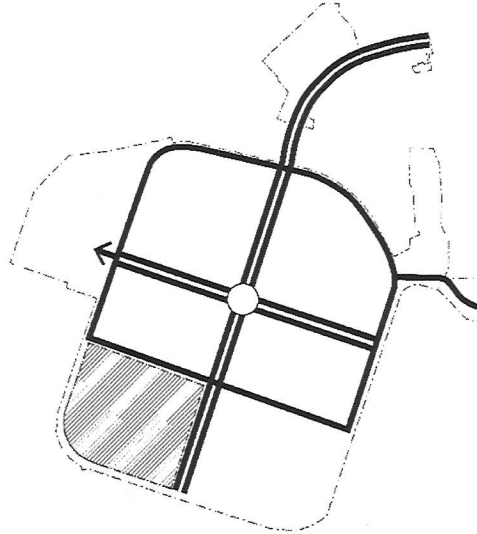

Concept 3 - Grid

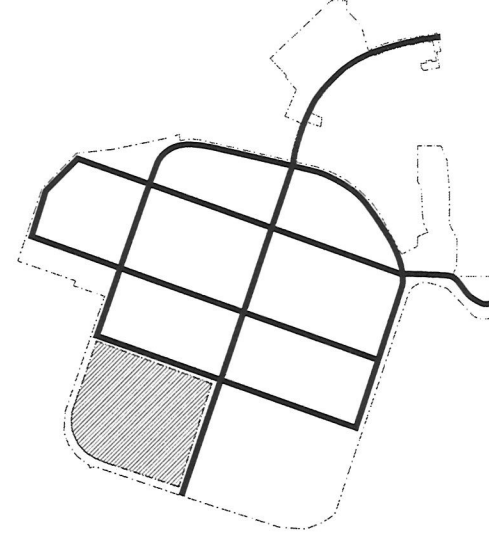

- Concept 1 – Loop
- Concept 2 – Boulevard
- Concept 3 – Grid

Of the three images, which park/open space configuration do you prefer? (Choose 1)

Concept 1 - Consolidated

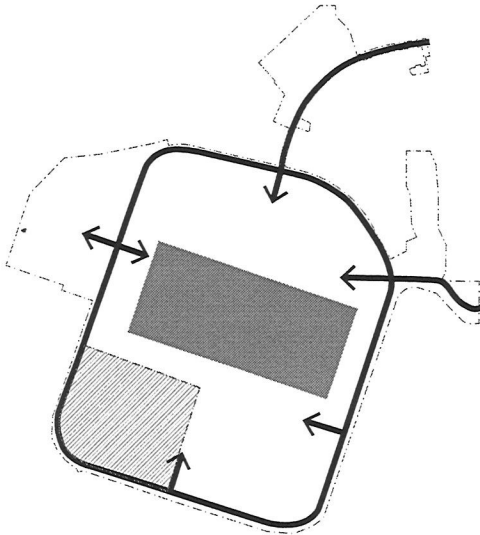

Concept 2 - Distributed

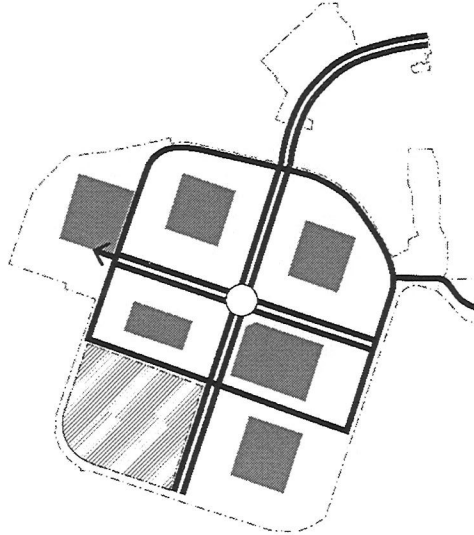

Concept 3 - Combination

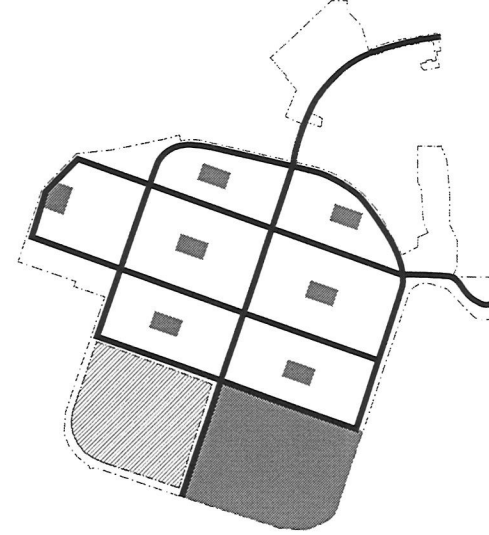

- Concept 1 – Consolidated
- Concept 2 – Distributed
- Concept 3 – Combination



Tell us more about you! What is your affiliation with Costa Mesa?

- I'm a resident
- I'm with an NGO/Non-Profit
- I'm a business owner
- I'm a developer
- I'm a property owner
- Other

For active open space areas, what types of facilities do you prefer? (Choose 2)

- Soccer fields
- Baseball fields
- Playgrounds
- Recreation Center
- Trails

Pickleball courts

What alternative modes of transportation do you prefer? (Choose 2)

- Walking
- Biking
- Golf Cart (or Neighborhood Electric Vehicle)
- Scooter
- Transit

Of the three images, which circulation concept do you prefer? (Choose 1)

Concept 1 - Loop

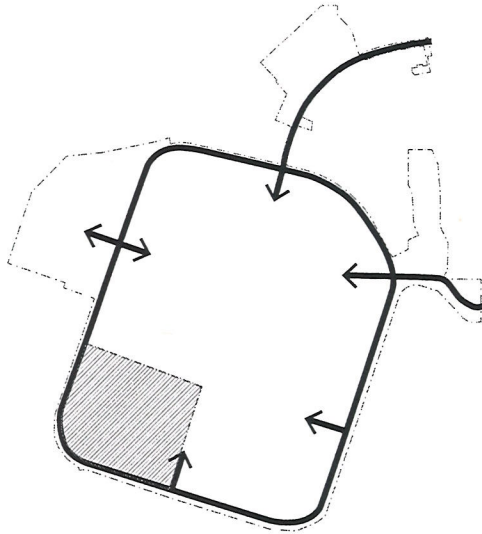

Concept 2 - Boulevard

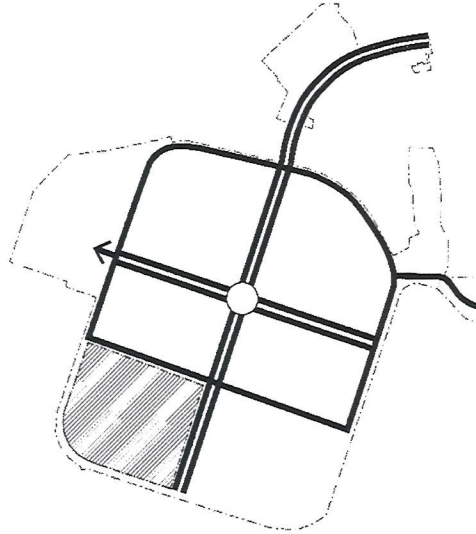

Concept 3 - Grid

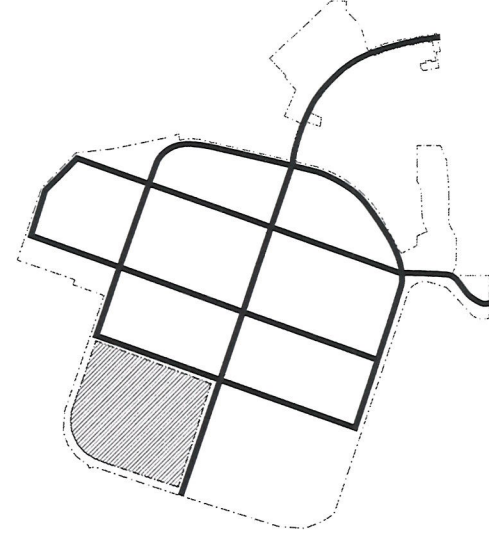

- Concept 1 – Loop
- Concept 2 – Boulevard
- Concept 3 – Grid

Of the three images, which park/open space configuration do you prefer? (Choose 1)

Concept 1 - Consolidated

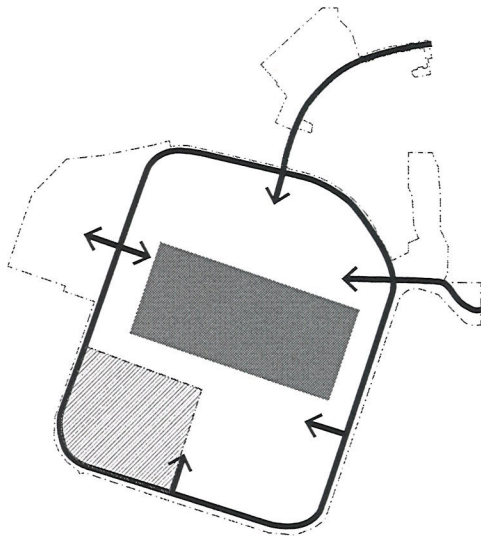

Concept 2 - Distributed

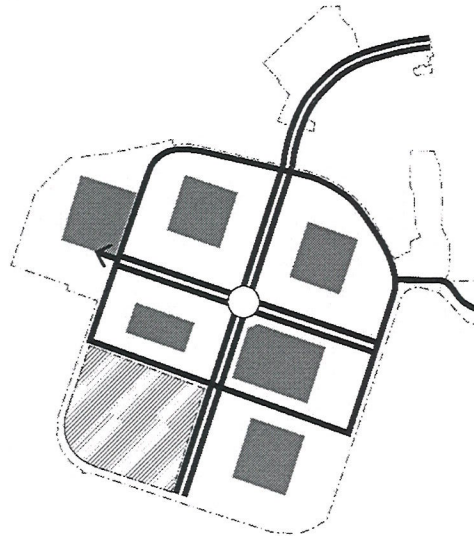

Concept 3 - Combination

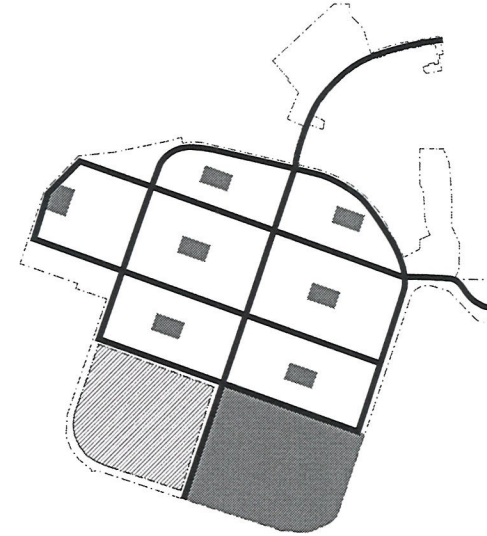

- Concept 1 – Consolidated
- Concept 2 – Distributed
- Concept 3 – Combination



DAN THOMPSON
2751 CANARY DR, C.M.

Tell us more about you! What is your affiliation with Costa Mesa?

- I'm a resident
- I'm with an NGO/Non-Profit
- I'm a business owner
- I'm a developer OF COMEDY
- I'm a property owner
- Other GAD FLY

For active open space areas, what types of facilities do you prefer? (Choose 2)

- Soccer fields
- Baseball fields
- Playgrounds
- Recreation Center
- Trails
- PICKLE BALL

What alternative modes of transportation do you prefer? (Choose 2)

- Walking
- Biking
- Golf Cart (or Neighborhood Electric Vehicle)
- Scooter
- Transit
- TELEPORTATION

Of the three images, which circulation concept do you prefer? (Choose 1)

Concept 1 - Loop

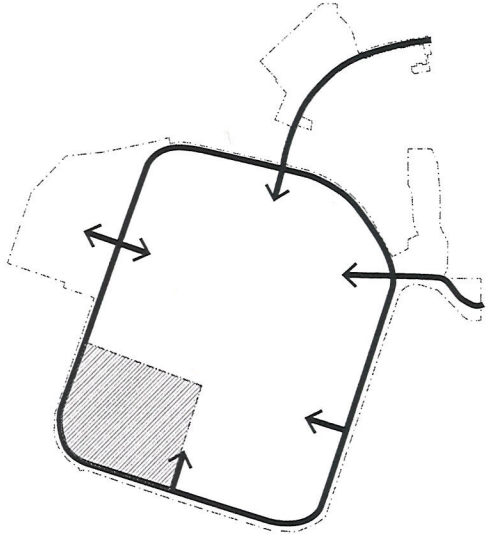

Concept 2 - Boulevard

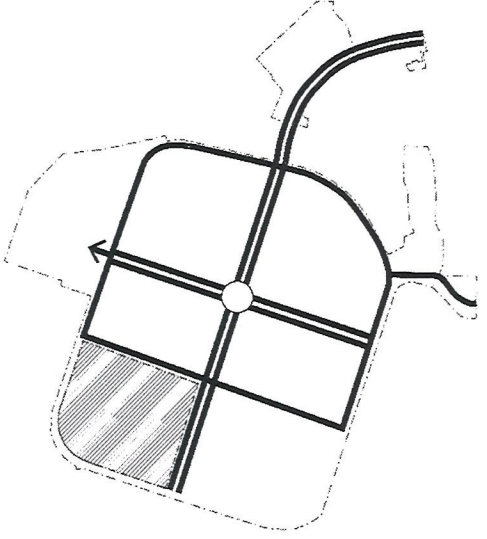

Concept 3 - Grid

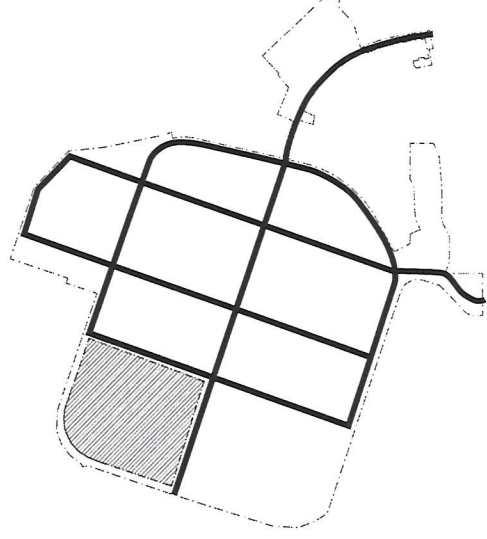

- Concept 1 – Loop
- Concept 2 – Boulevard
- Concept 3 – Grid

RACEWAY

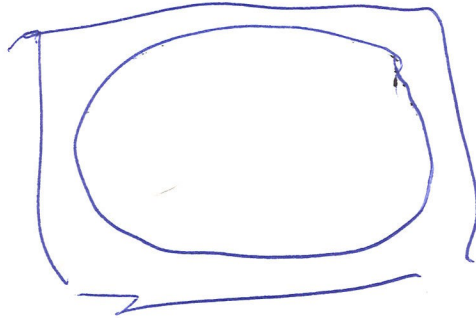

Of the three images, which park/open space configuration do you prefer? (Choose 1)

Concept 1 - Consolidated

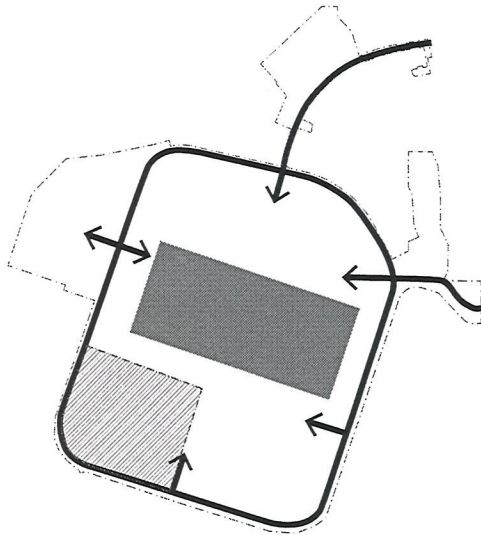

Concept 2 - Distributed

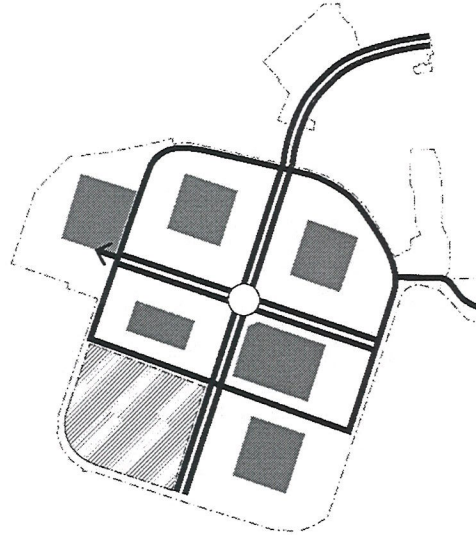

Concept 3 - Combination

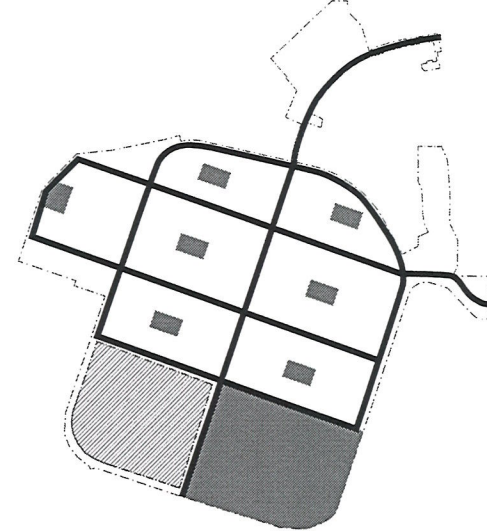

- Concept 1 – Consolidated *- NFL SIZE FIELD*
- Concept 2 – Distributed
- Concept 3 – Combination



Tell us more about you! What is your affiliation with Costa Mesa?

- I'm a resident
- I'm with an NGO/Non-Profit
- I'm a business owner
- I'm a developer
- I'm a property owner
- Other *Retired senior woman; Caregiver work*

For active open space areas, what types of facilities do you prefer? (Choose 2)

- Soccer fields
- Baseball fields
- Playgrounds
- Recreation Center
- Trails

What alternative modes of transportation do you prefer? (Choose 2)

- Walking
- Biking
- Golf Cart (or Neighborhood Electric Vehicle)
- Scooter
- Transit

Of the three images, which circulation concept do you prefer? (Choose 1)

Concept 1 - Loop

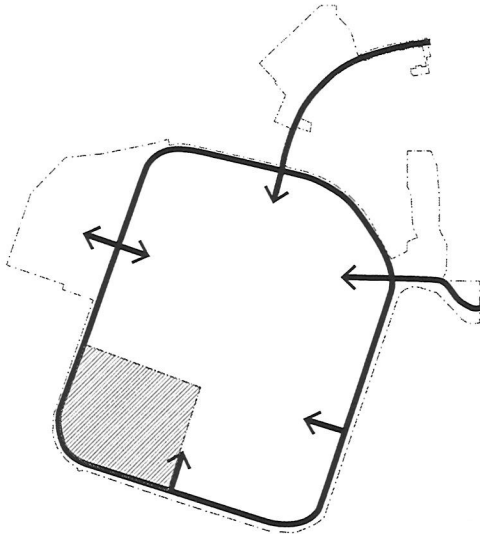

Concept 2 - Boulevard

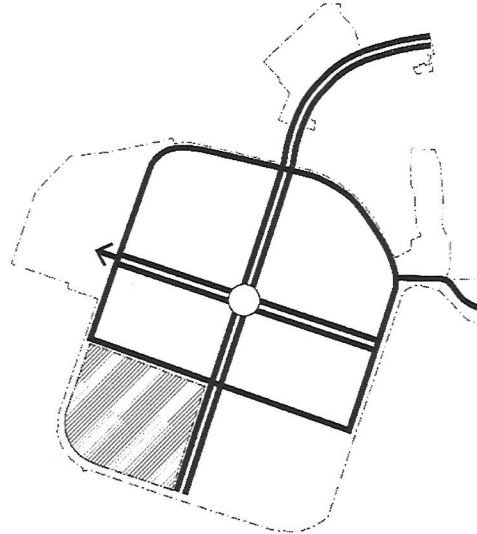

Concept 3 - Grid

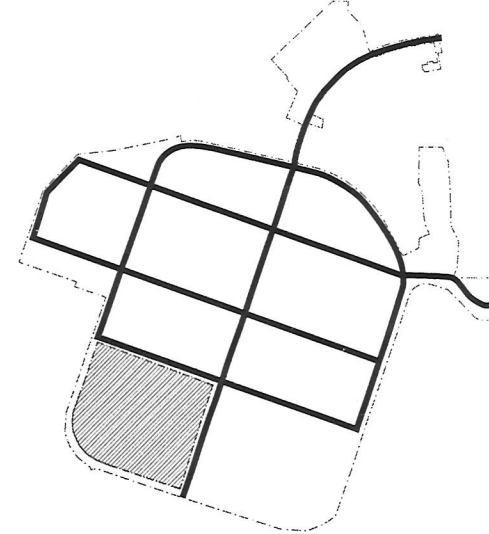

- Concept 1 – Loop
- Concept 2 – Boulevard
- Concept 3 – Grid

Of the three images, which park/open space configuration do you prefer? (Choose 1)

Concept 1 - Consolidated

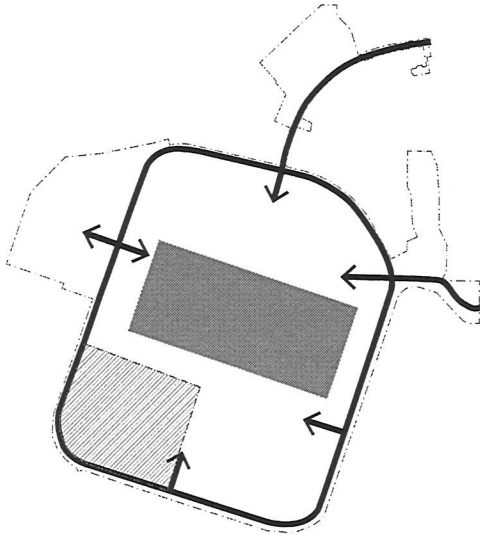

Concept 2 - Distributed

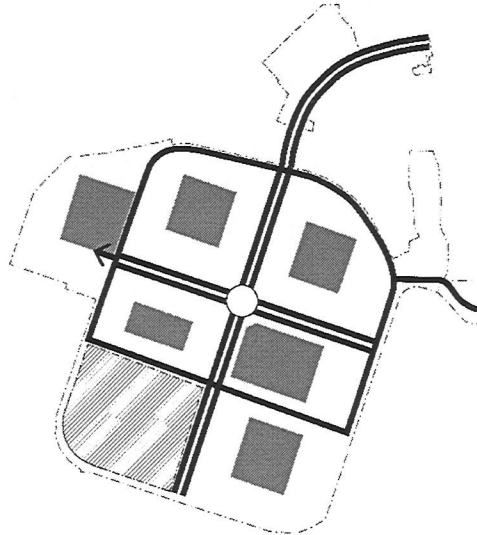

Concept 3 - Combination

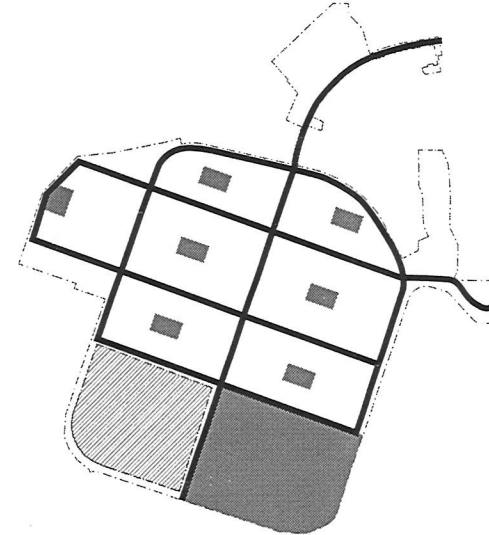

- Concept 1 – Consolidated
- Concept 2 – Distributed
- Concept 3 – Combination



Tell us more about you! What is your affiliation with Costa Mesa?

- I'm a resident
- I'm with an NGO/Non-Profit
- I'm a business owner
- I'm a developer
- I'm a property owner
- Other

For active open space areas, what types of facilities do you prefer? (Choose 2)

- Soccer fields
- Baseball fields
- Playgrounds
- Recreation Center
- Trails

What alternative modes of transportation do you prefer? (Choose 2)

- Walking
- Biking
- Golf Cart (or Neighborhood Electric Vehicle)
- Scooter
- Transit

Of the three images, which circulation concept do you prefer? (Choose 1)

Concept 1 - Loop

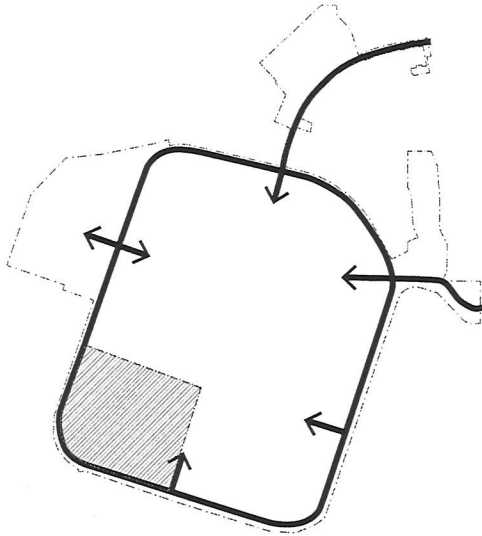

Concept 2 - Boulevard

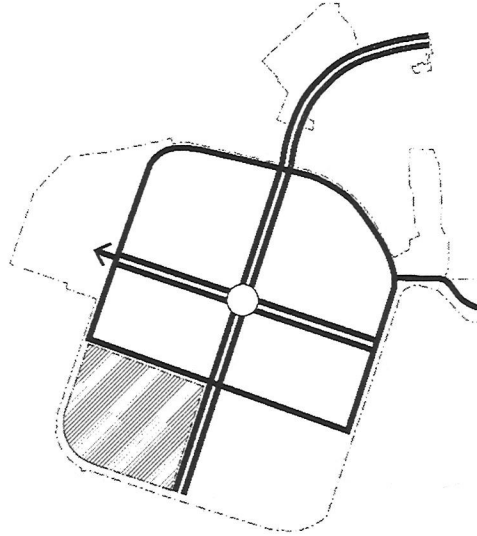

Concept 3 - Grid

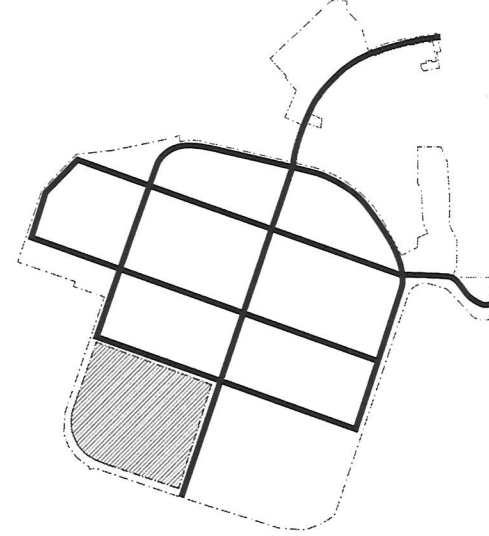

- Concept 1 – Loop
- Concept 2 – Boulevard
- Concept 3 – Grid

Of the three images, which park/open space configuration do you prefer? (Choose 1)

Concept 1 - Consolidated

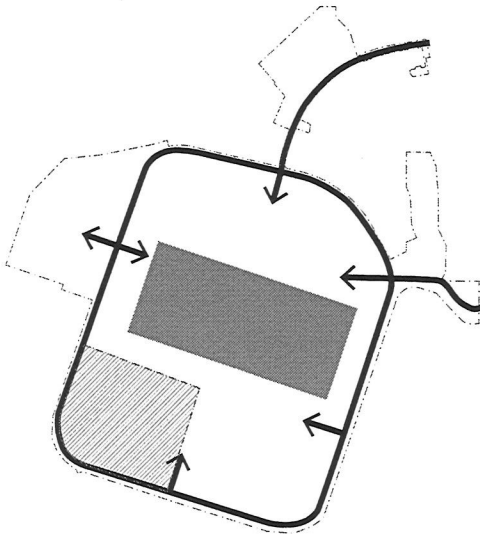

Concept 2 - Distributed

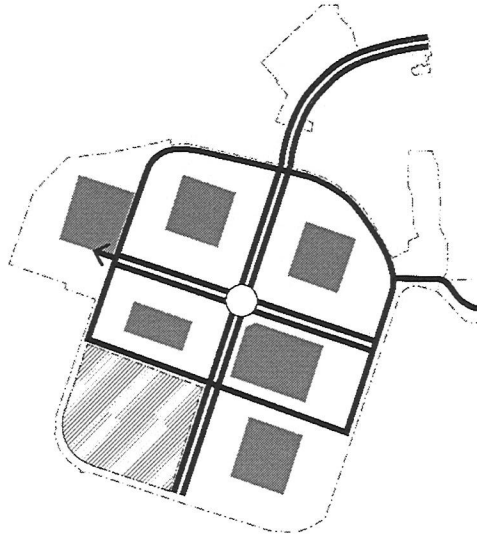

Concept 3 - Combination

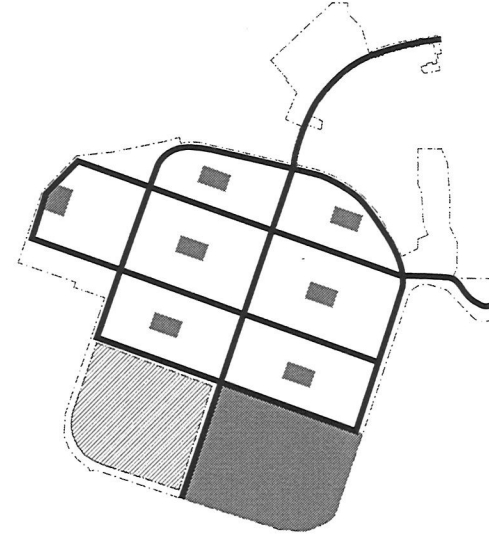

- Concept 1 – Consolidated
- Concept 2 – Distributed
- Concept 3 – Combination

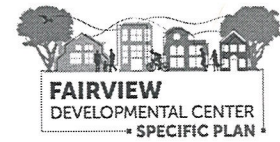

Tell us more about you! What is your affiliation with Costa Mesa?

- I'm a resident
- I'm with an NGO/Non-Profit
- I'm a business owner
- I'm a developer
- I'm a property owner
- Other

For active open space areas, what types of facilities do you prefer? (Choose 2)

- Soccer fields
 - Baseball fields
 - Playgrounds
 - Recreation Center
 - Trails
- Who MANAGES greens, maintenance, Reservation needed, crowd control all a Sports complex?*

What alternative modes of transportation do you prefer? (Choose 2)

- Walking
- Biking
- Golf Cart (or Neighborhood Electric Vehicle)
- Scooter
- Transit

Of the three images, which circulation concept do you prefer? (Choose 1)

Concept 1 - Loop

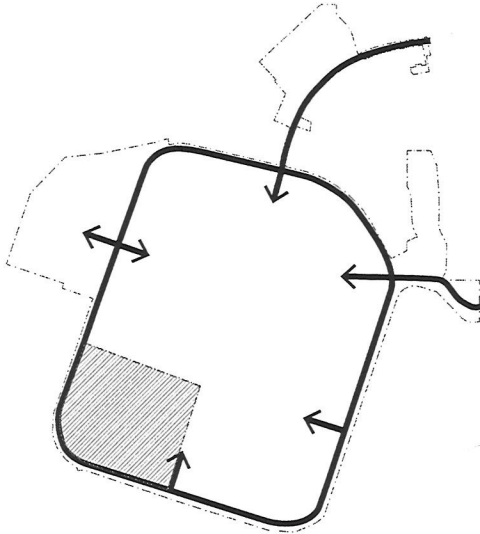

Concept 2 - Boulevard

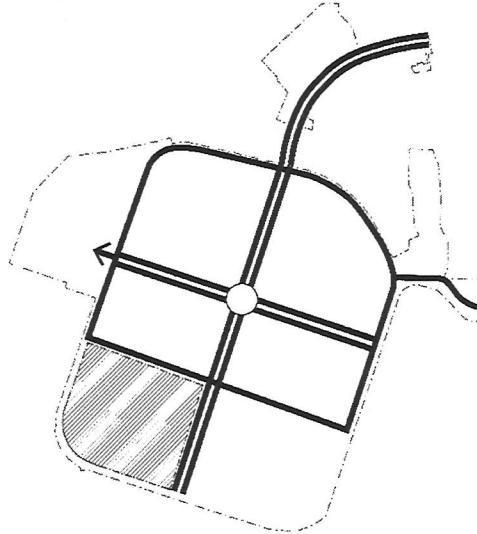

Concept 3 - Grid

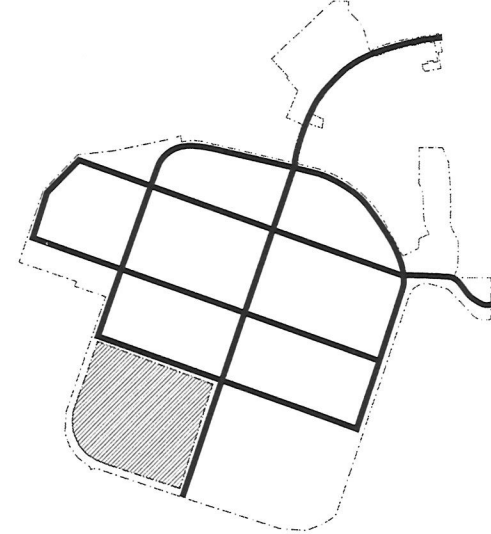

- Concept 1 – Loop
- Concept 2 – Boulevard
- Concept 3 – Grid

Of the three images, which park/open space configuration do you prefer? (Choose 1)

Concept 1 - Consolidated

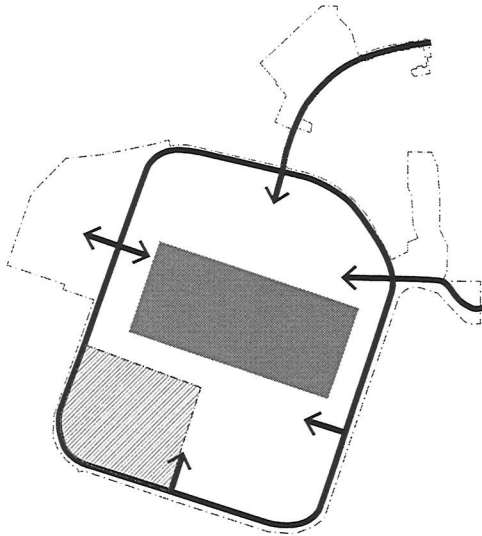

Concept 2 - Distributed

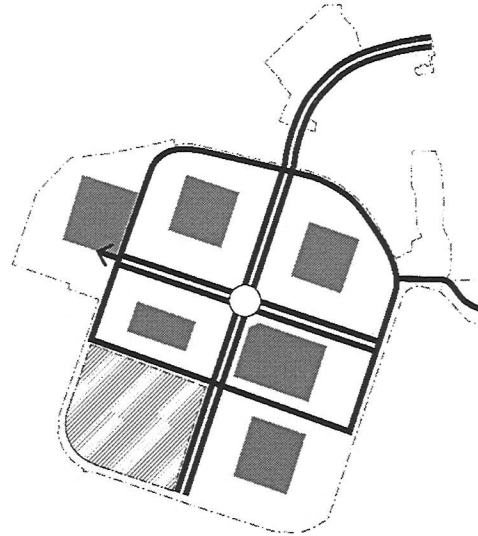

Concept 3 - Combination

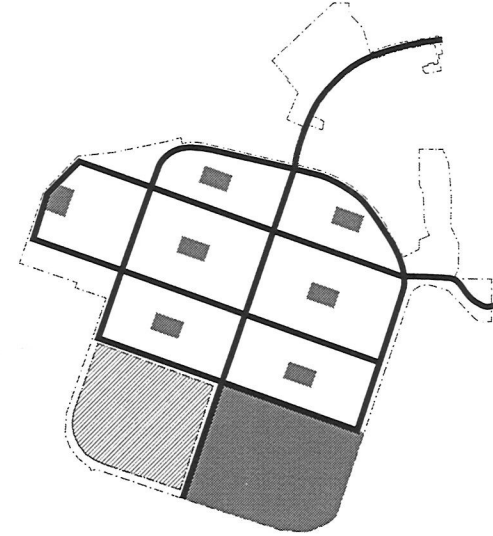

- Concept 1 – Consolidated
- Concept 2 – Distributed
- Concept 3 – Combination



Tell us more about you! What is your affiliation with Costa Mesa?

- I'm a resident
- I'm with an NGO/Non-Profit
- I'm a business owner
- I'm a developer
- I'm a property owner
- Other

*(Place works)
Consultant
for Project*

For active open space areas, what types of facilities do you prefer? (Choose 2)

- Soccer fields
- Baseball fields
- Playgrounds
- Recreation Center
- Trails = Green belt

What alternative modes of transportation do you prefer? (Choose 2)

- Walking
- Biking
- Golf Cart (or Neighborhood Electric Vehicle)
- Scooter
- Transit

Of the three images, which circulation concept do you prefer? (Choose 1)

Concept 1 - Loop

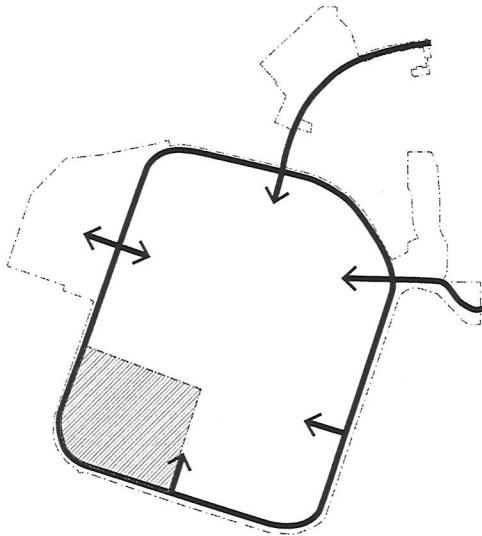

Concept 2 - Boulevard

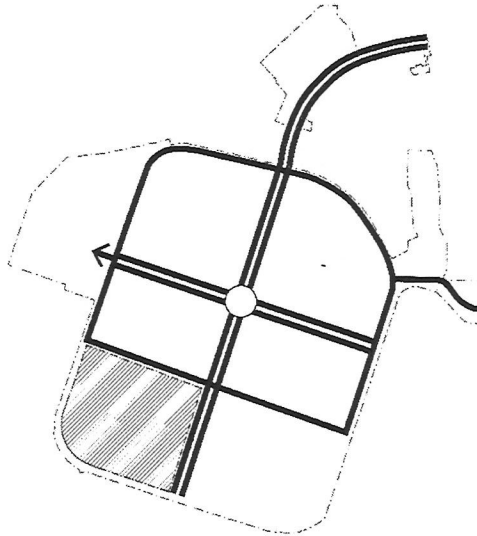

Concept 3 - Grid

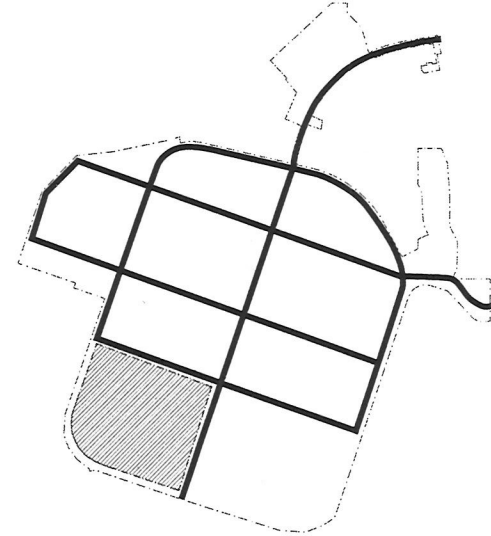

- Concept 1 – Loop
- Concept 2 – Boulevard
- Concept 3 – Grid

Of the three images, which park/open space configuration do you prefer? (Choose 1)

Concept 1 - Consolidated

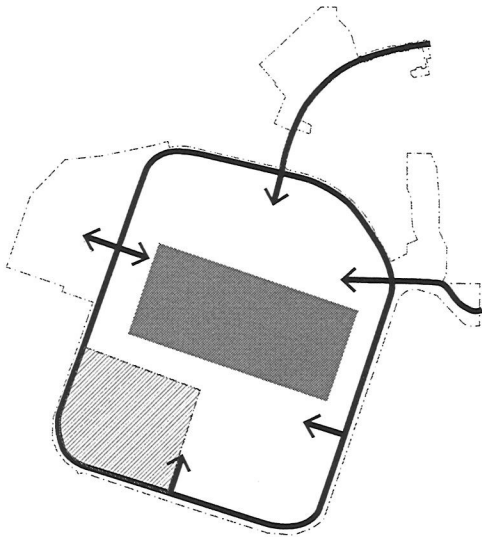

Concept 2 - Distributed

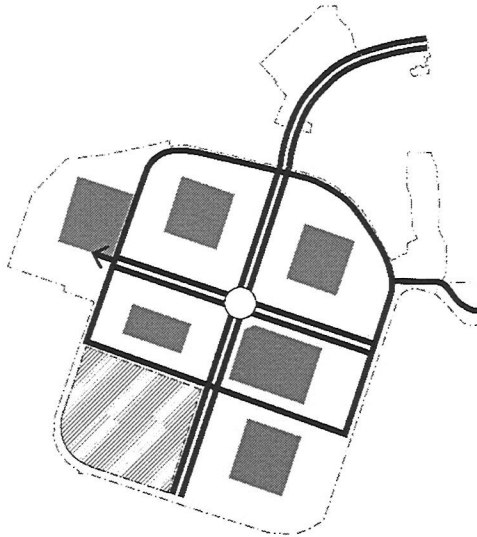

Concept 3 - Combination

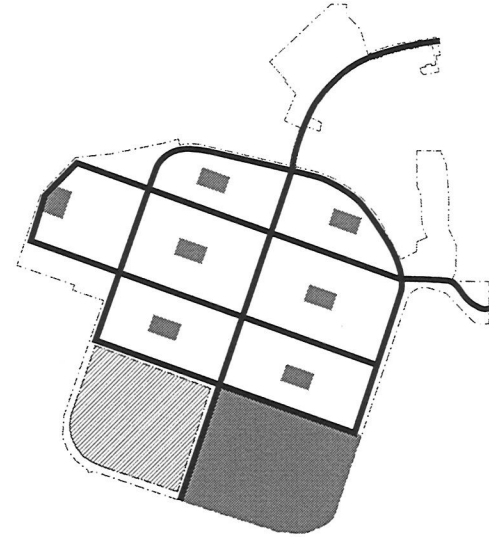

- Concept 1 – Consolidated
- Concept 2 – Distributed
- Concept 3 – Combination



Tell us more about you! What is your affiliation with Costa Mesa?

- I'm a resident
- I'm with an NGO/Non-Profit
- I'm a business owner
- I'm a developer
- I'm a property owner
- Other

For active open space areas, what types of facilities do you prefer? (Choose 2)

- Soccer fields
- Baseball fields
- Playgrounds
- Recreation Center
- Trails

What alternative modes of transportation do you prefer? (Choose 2)

- Walking
- Biking
- Golf Cart (or Neighborhood Electric Vehicle)
- Scooter
- Transit

Of the three images, which circulation concept do you prefer? (Choose 1)

Concept 1 - Loop

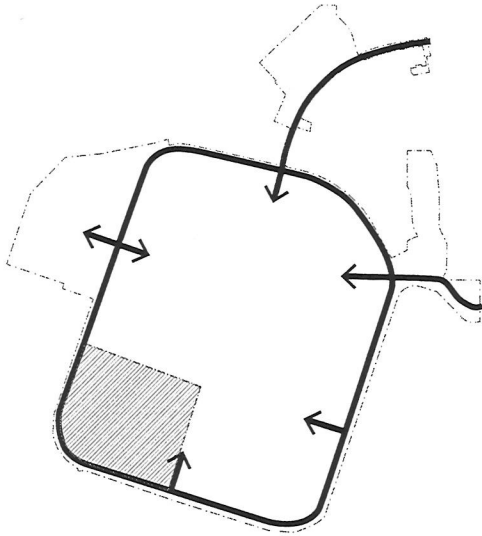

Concept 2 - Boulevard

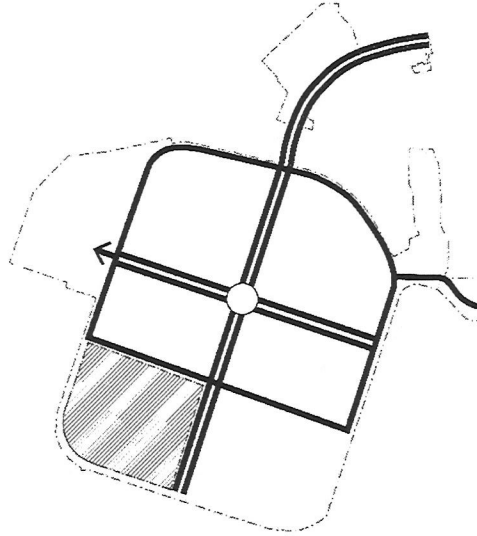

Concept 3 - Grid

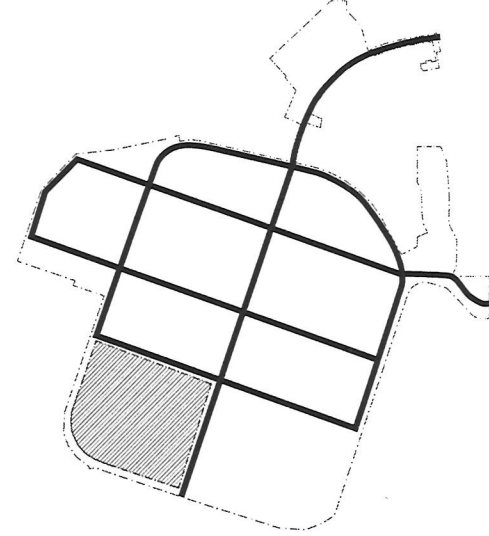

- Concept 1 – Loop
- Concept 2 – Boulevard
- Concept 3 – Grid

Of the three images, which park/open space configuration do you prefer? (Choose 1)

Concept 1 - Consolidated

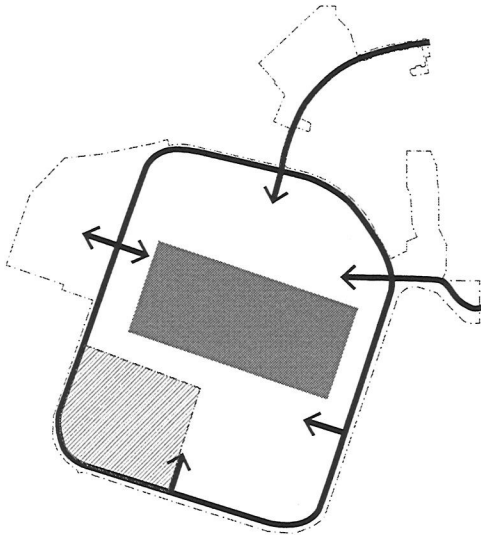

Concept 2 - Distributed

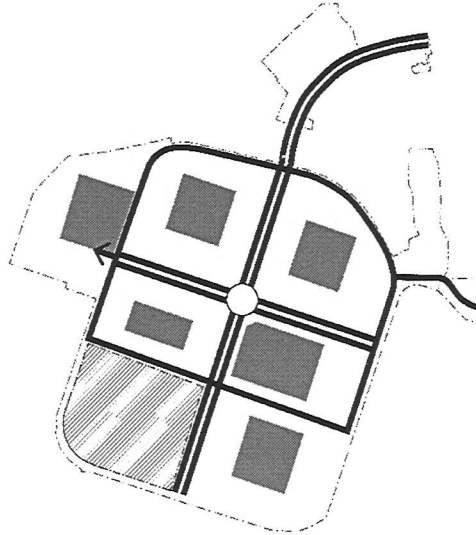

Concept 3 - Combination

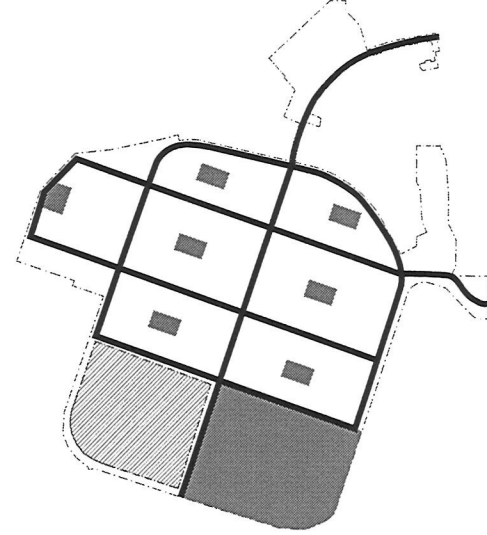

- Concept 1 – Consolidated
- Concept 2 – Distributed
- Concept 3 – Combination



Tell us more about you! What is your affiliation with Costa Mesa?

- I'm a resident
- I'm with an NGO/Non-Profit
- I'm a business owner
- I'm a developer
- I'm a property owner
- Other

For active open space areas, what types of facilities do you prefer? (Choose 2)

- Soccer fields
- Baseball fields
- Playgrounds
- Recreation Center
- Trails

What alternative modes of transportation do you prefer? (Choose 2)

- Walking
- Biking
- Golf Cart (or Neighborhood Electric Vehicle)
- Scooter
- Transit

Of the three images, which circulation concept do you prefer? (Choose 1)

Concept 1 - Loop

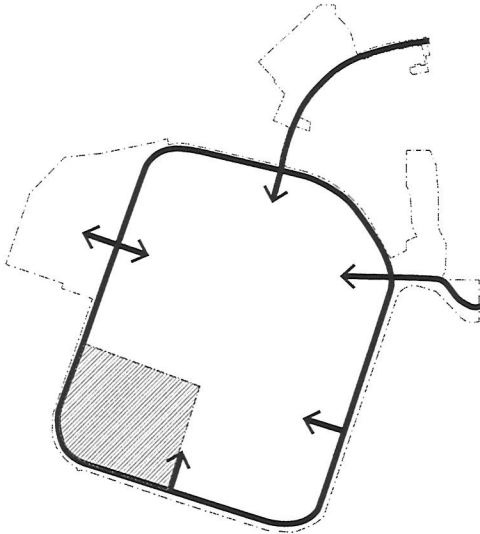

Concept 2 - Boulevard

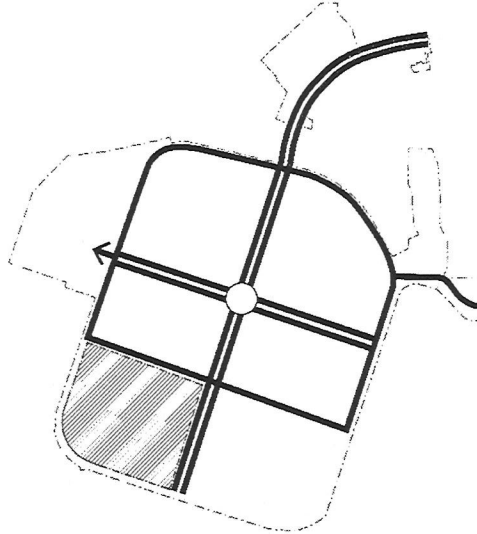

Concept 3 - Grid

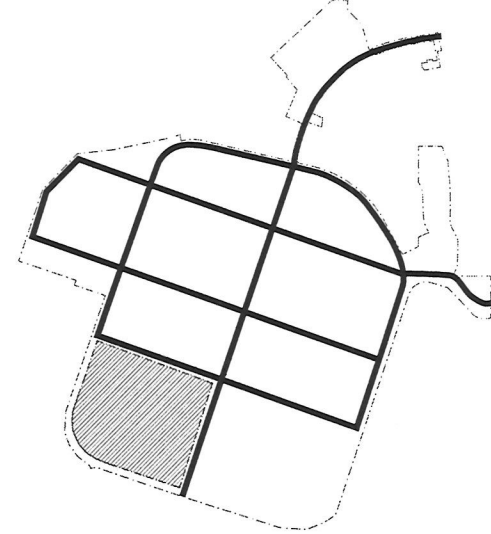

- Concept 1 – Loop
- Concept 2 – Boulevard
- Concept 3 – Grid

Of the three images, which park/open space configuration do you prefer? (Choose 1)

Concept 1 - Consolidated

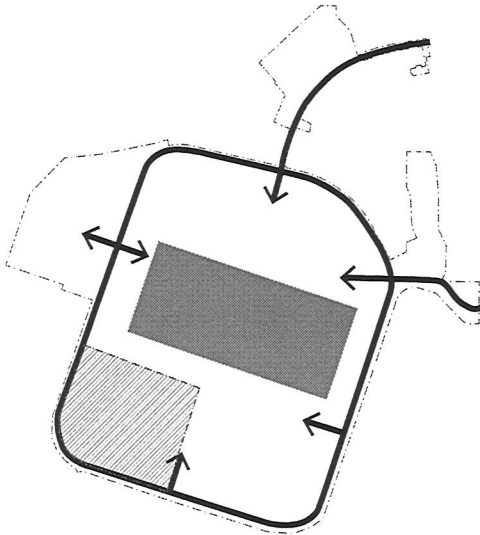

Concept 2 - Distributed

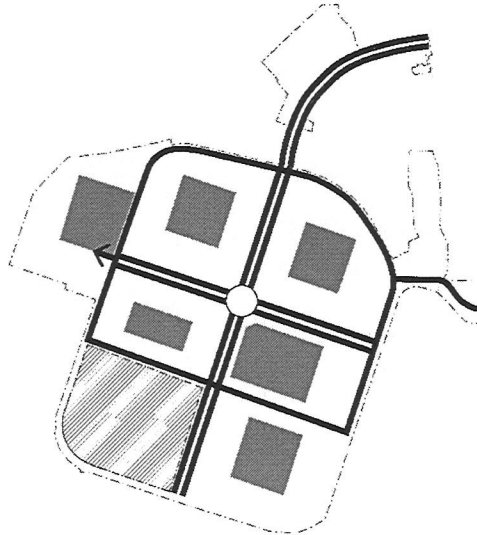

Concept 3 - Combination

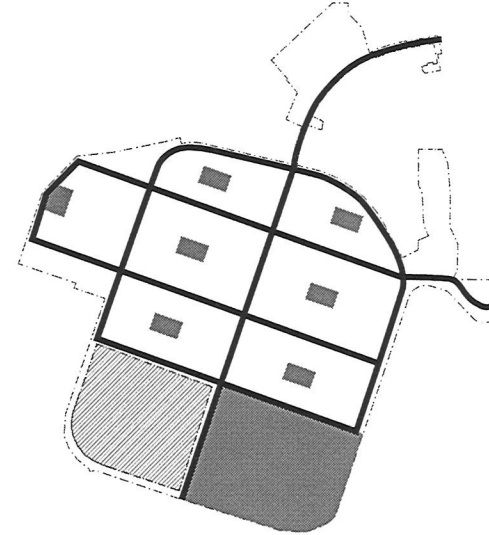

- Concept 1 – Consolidated
- Concept 2 – Distributed
- Concept 3 – Combination



Tell us more about you! What is your affiliation with Costa Mesa?

- I'm a resident
- I'm with an NGO/Non-Profit
- I'm a business owner
- I'm a developer
- I'm a property owner
- Other

For active open space areas, what types of facilities do you prefer? (Choose 2)

- Soccer fields
- ~~Baseball fields~~
- Playgrounds
- Recreation Center
- Trails

TENNIS, PICKLEBALL, POOL

What alternative modes of transportation do you prefer? (Choose 2)

- Walking
- Biking
- Golf Cart (or Neighborhood Electric Vehicle)
- Scooter
- Transit

Of the three images, which circulation concept do you prefer? (Choose 1)

Concept 1 - Loop

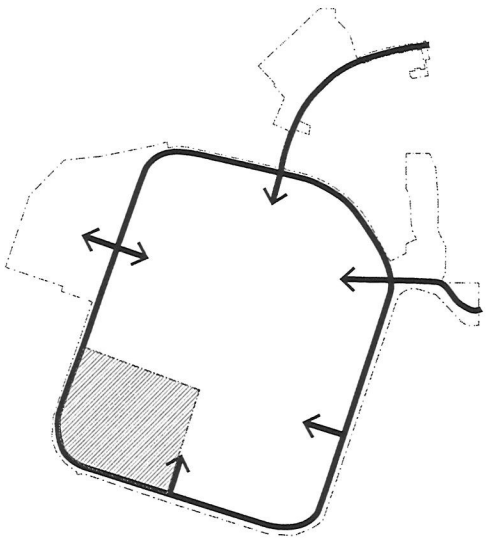

Concept 2 - Boulevard

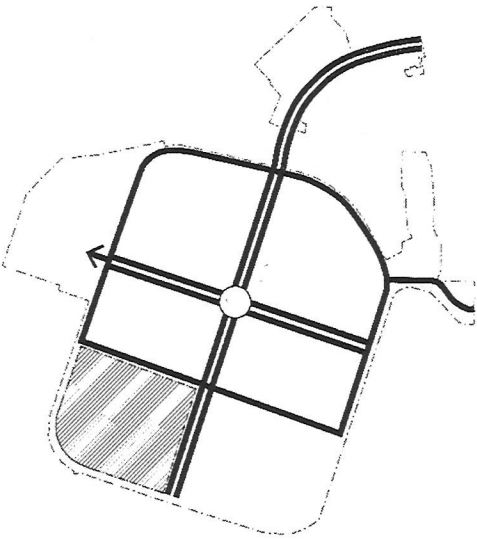

Concept 3 - Grid

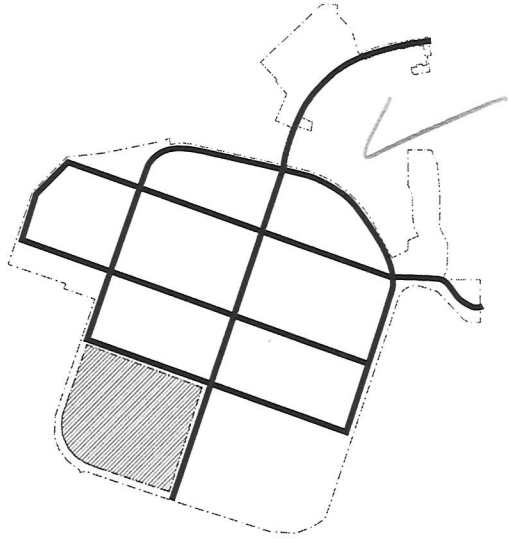

- Concept 1 – Loop
- Concept 2 – Boulevard
- Concept 3 – Grid

Of the three images, which park/open space configuration do you prefer? (Choose 1)

Concept 1 - Consolidated

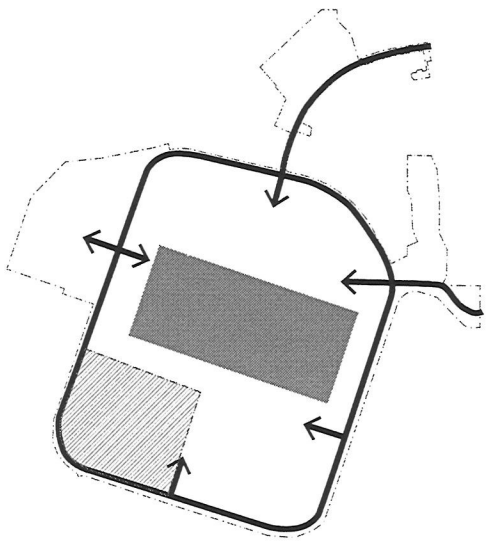

Concept 2 - Distributed

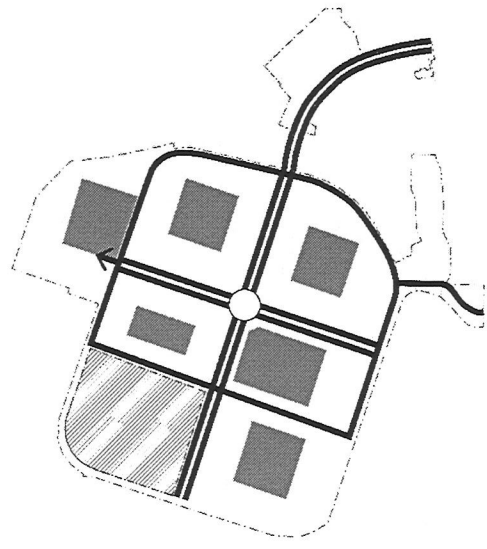

Concept 3 - Combination

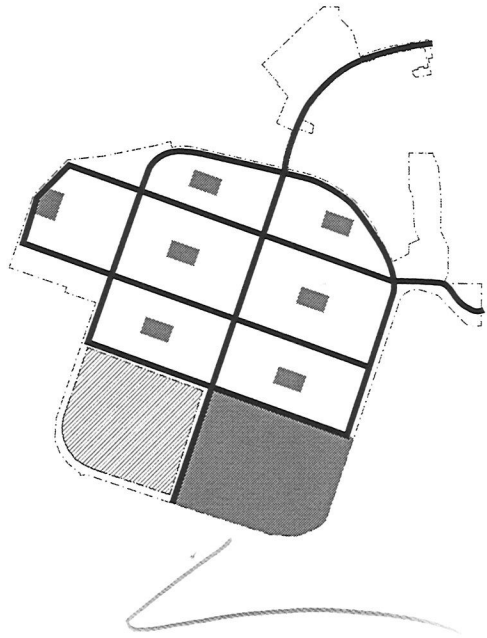

- Concept 1 – Consolidated
- Concept 2 – Distributed
- Concept 3 – Combination



Tell us more about you! What is your affiliation with Costa Mesa?

- I'm a resident
- I'm with an NGO/Non-Profit
- I'm a business owner
- I'm a developer
- I'm a property owner
- Other

For active open space areas, what types of facilities do you prefer? (Choose 2)

- Soccer fields
- Baseball fields
- Playgrounds
- Recreation Center
- Trails

a tot park like on the corner of Santa Ana + Fair

What alternative modes of transportation do you prefer? (Choose 2)

- Walking
- Biking
- Golf Cart (or Neighborhood Electric Vehicle)
- Scooter
- Transit

Of the three images, which circulation concept do you prefer? (Choose 1)

Concept 1 - Loop

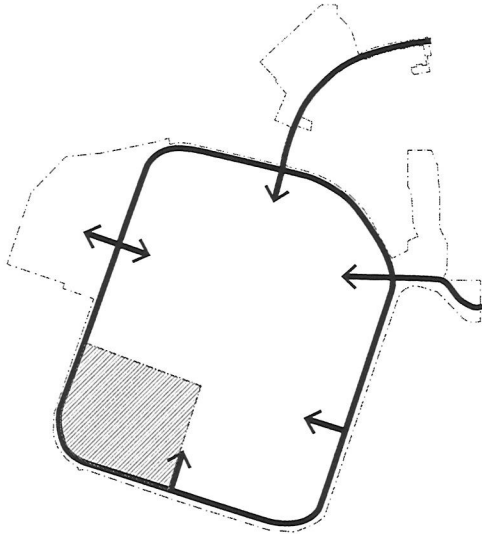

Concept 2 - Boulevard

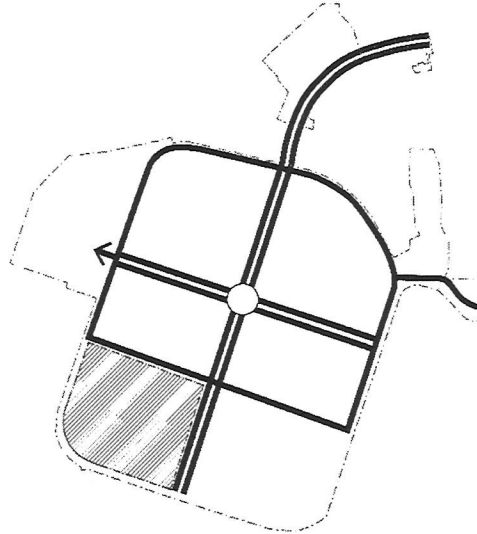

Concept 3 - Grid

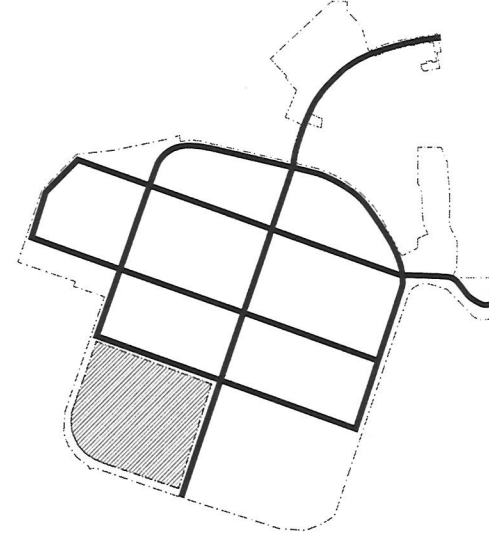

- Concept 1 – Loop
- Concept 2 – Boulevard
- Concept 3 – Grid

Of the three images, which park/open space configuration do you prefer? (Choose 1)

Concept 1 - Consolidated

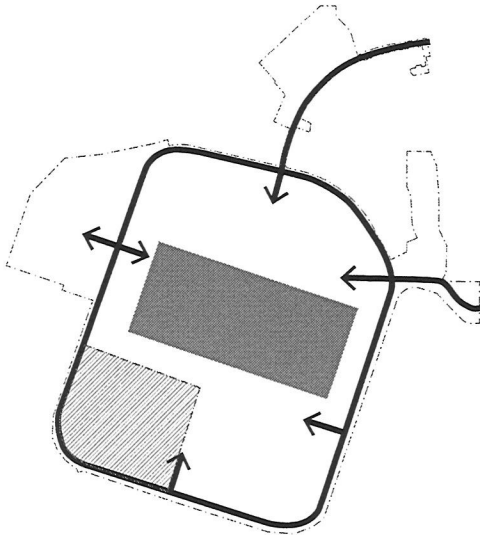

Concept 2 - Distributed

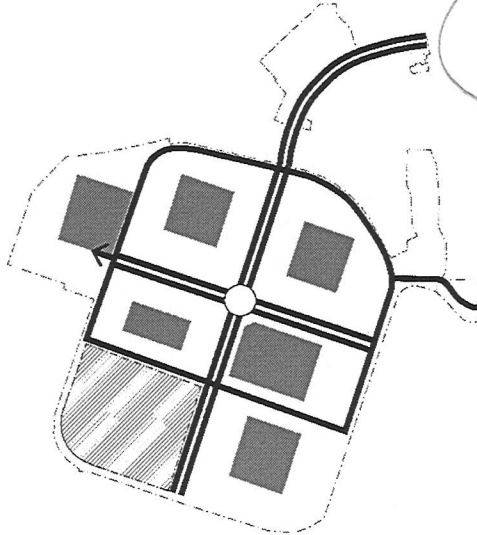

Concept 3 - Combination

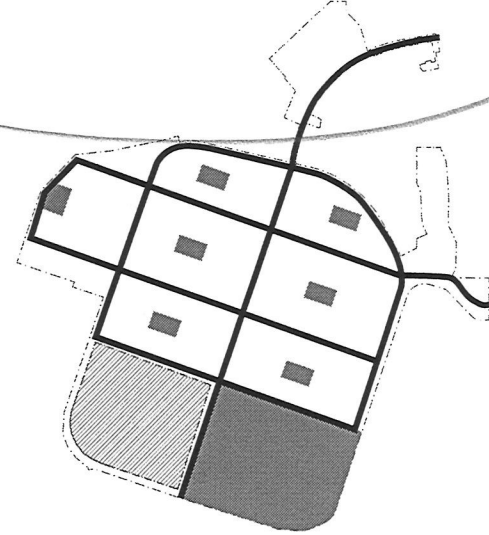

- Concept 1 – Consolidated
- Concept 2 – Distributed
- Concept 3 – Combination



Tell us more about you! What is your affiliation with Costa Mesa?

- I'm a resident
- I'm with an NGO/Non-Profit
- I'm a business owner
- I'm a developer
- I'm a property owner
- Other

For active open space areas, what types of facilities do you prefer? (Choose 2)

- Soccer fields
 - Baseball fields
 - Playgrounds
 - Recreation Center
 - Trails
- Butterfly garden*

What alternative modes of transportation do you prefer? (Choose 2)

- Walking
- Biking
- Golf Cart (or Neighborhood Electric Vehicle)
- Scooter
- Transit

Of the three images, which circulation concept do you prefer? (Choose 1)

Concept 1 - Loop

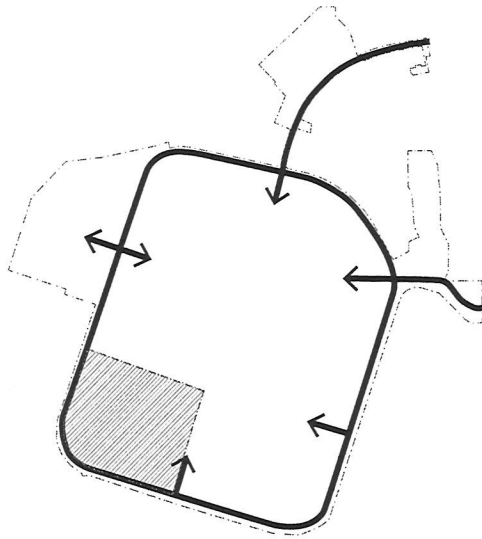

Concept 2 - Boulevard

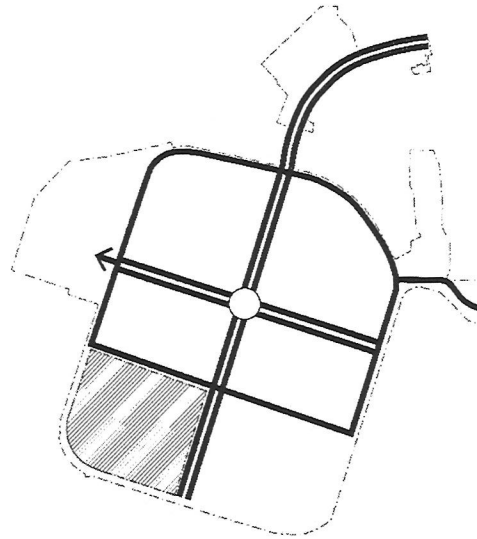

Concept 3 - Grid

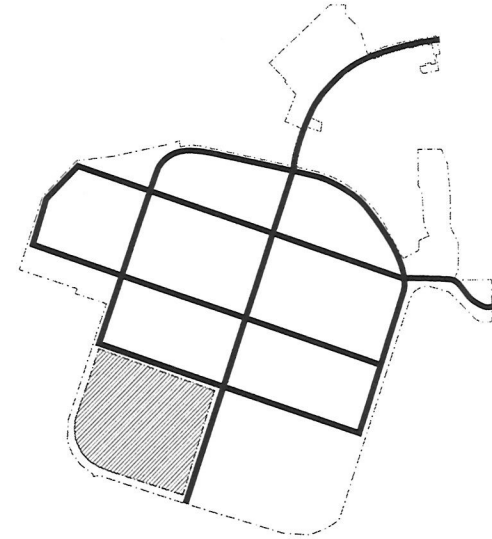

- Concept 1 – Loop
- Concept 2 – Boulevard
- Concept 3 – Grid

Of the three images, which park/open space configuration do you prefer? (Choose 1)

Concept 1 - Consolidated

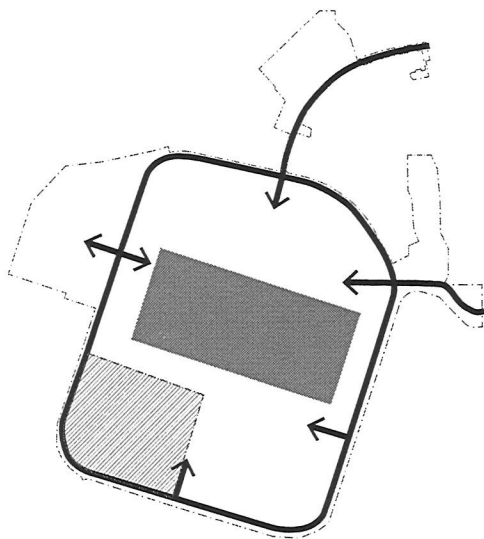

Concept 2 - Distributed

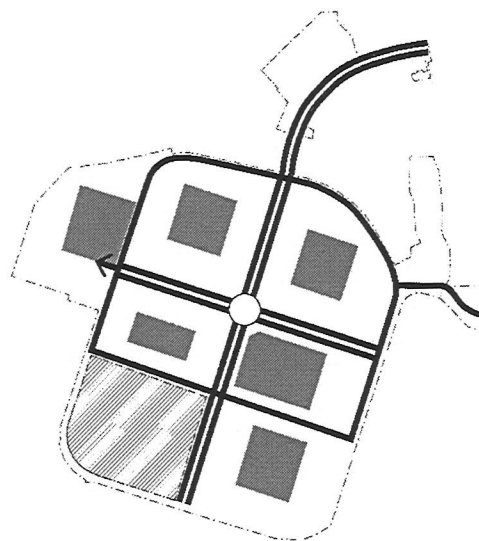

Concept 3 - Combination

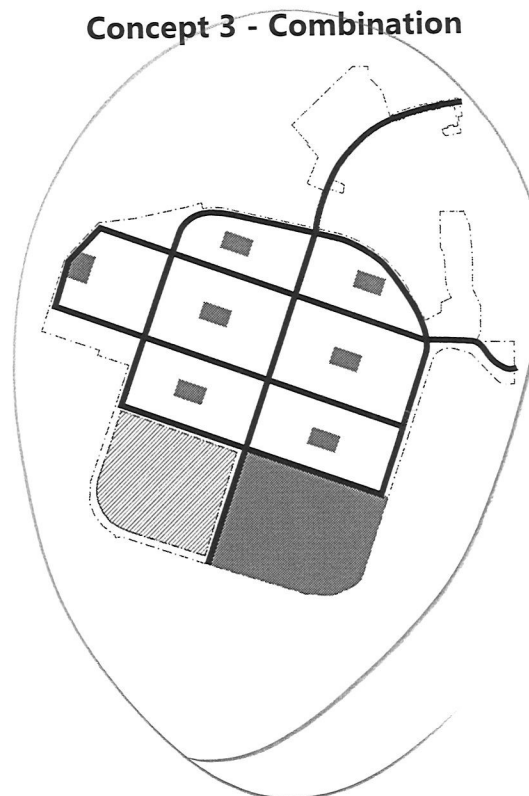

- Concept 1 – Consolidated
- Concept 2 – Distributed
- Concept 3 – Combination



Tell us more about you! What is your affiliation with Costa Mesa?

- I'm a resident
- I'm with an NGO/Non-Profit
- I'm a business owner
- I'm a developer
- I'm a property owner
- Other

For active open space areas, what types of facilities do you prefer? (Choose 2)

- Soccer fields
- Baseball fields
- Playgrounds
- Recreation Center
- Trails

PIAZAS / PLAZAS
WITH BENCHES AND ARCHITECTURAL FOUNTAIN-WATER FALL - ?

What alternative modes of transportation do you prefer? (Choose 2)

- Walking
- Biking
- Golf Cart (or Neighborhood Electric Vehicle)
- Scooter
- Transit

Of the three images, which circulation concept do you prefer? (Choose 1)

Concept 1 - Loop

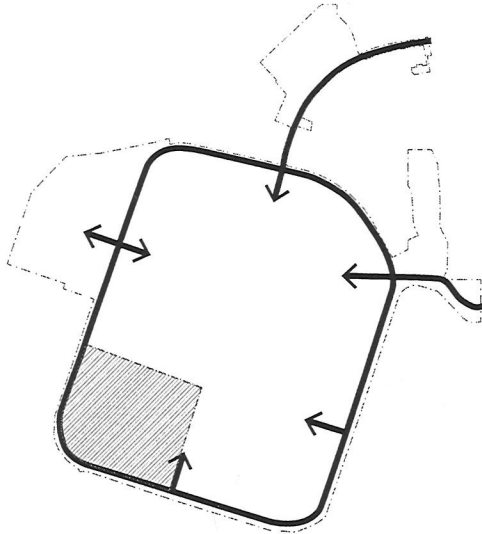

Concept 2 - Boulevard

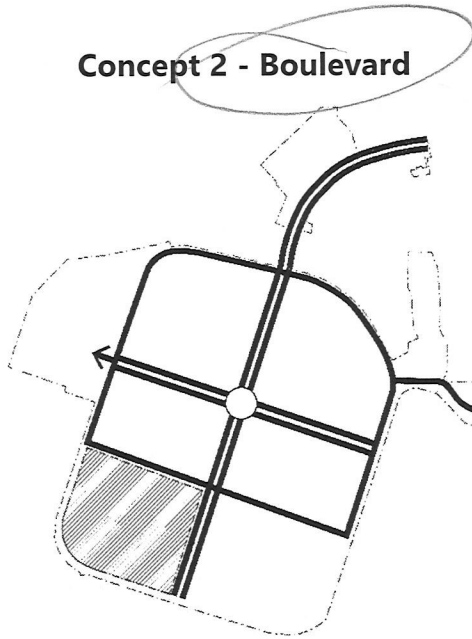

Concept 3 - Grid

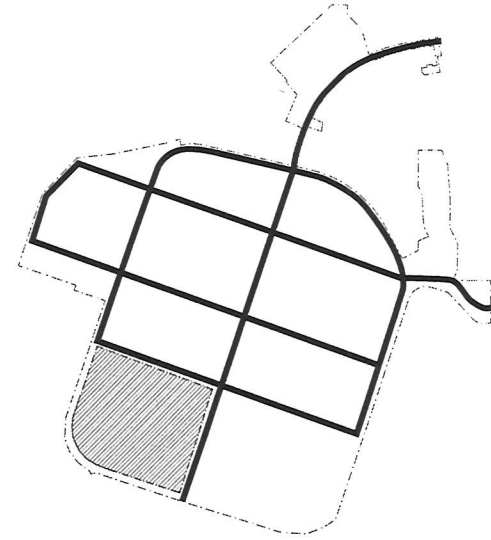

- Concept 1 – Loop
- Concept 2 – Boulevard
- Concept 3 – Grid

Of the three images, which park/open space configuration do you prefer? (Choose 1)

Concept 1 - Consolidated

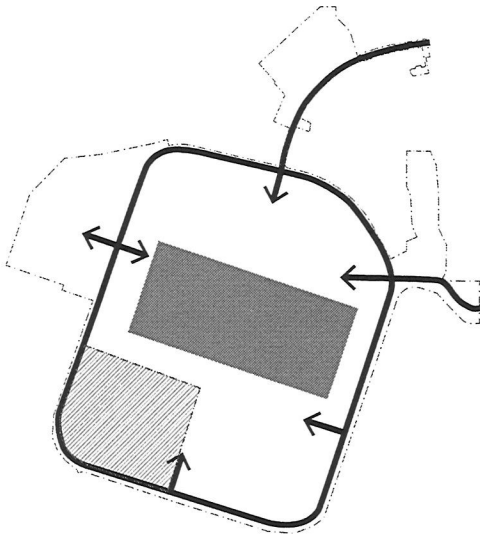

Concept 2 - Distributed

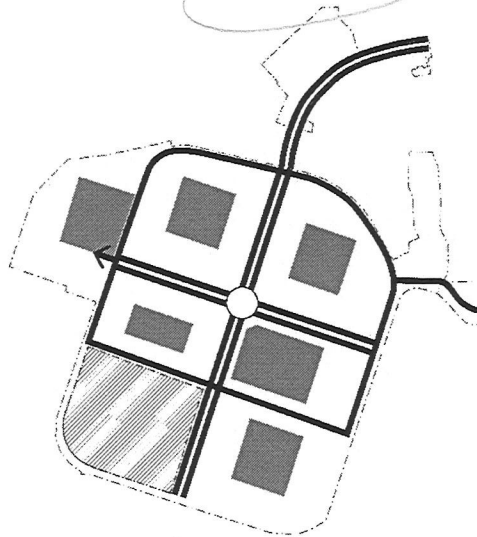

Concept 3 - Combination

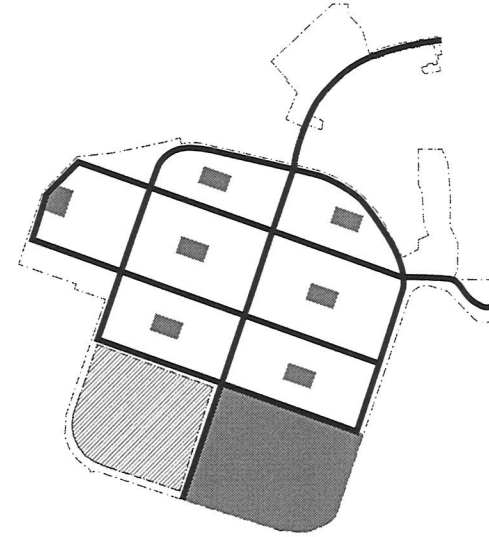

- Concept 1 – Consolidated
- Concept 2 – Distributed
- Concept 3 – Combination

RKK HUFFMAN
huffmanr@gmail.com



Tell us more about you! What is your affiliation with Costa Mesa?

- I'm a resident
- I'm with an NGO/Non-Profit
- I'm a business owner
- I'm a developer
- I'm a property owner
- Other

For active open space areas, what types of facilities do you prefer? (Choose 2)

- Soccer fields
- Baseball fields
- Playgrounds
- Recreation Center
- Trails

TENNIS / PICKLE BALL

What alternative modes of transportation do you prefer? (Choose 2)

- Walking
- Biking
- Golf Cart (or Neighborhood Electric Vehicle)
- Scooter
- Transit

Of the three images, which circulation concept do you prefer? (Choose 1)

Concept 1 - Loop

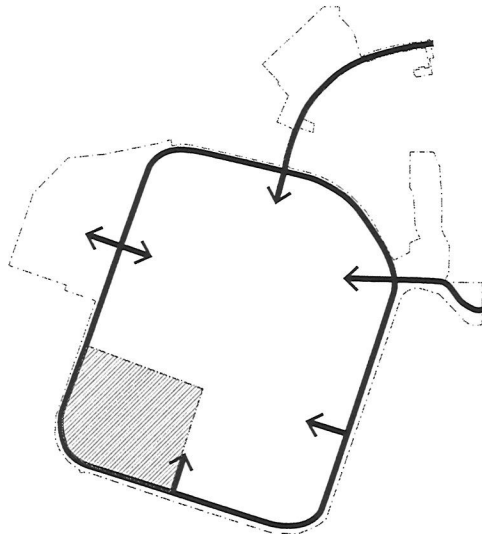

TOO DIVISIVE

Concept 2 - Boulevard

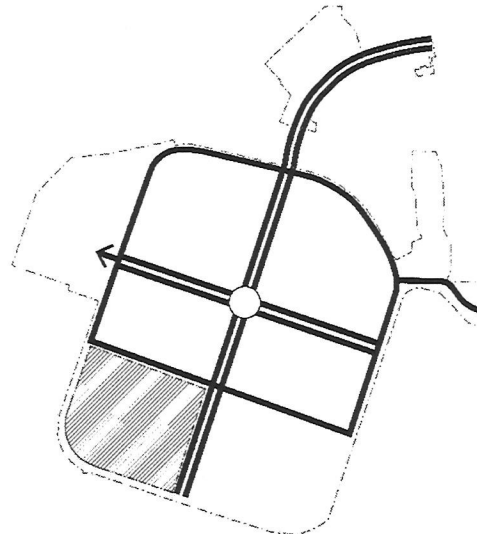

DISCOURAGE CAR
TRAFFIC & SPEED

Concept 3 - Grid

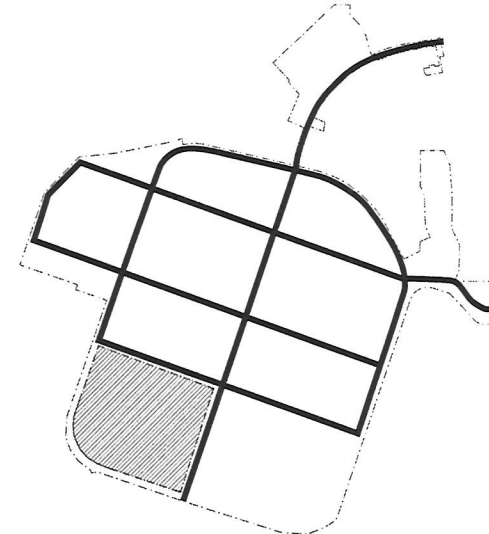

Concept 1 – Loop

Concept 2 – Boulevard

Concept 3 – Grid

NARROW STREETS, LOW SPEED LIMITS
PEDESTRIAN ONLY WALKWAYS

Of the three images, which park/open space configuration do you prefer? (Choose 1)

Concept 1 - Consolidated

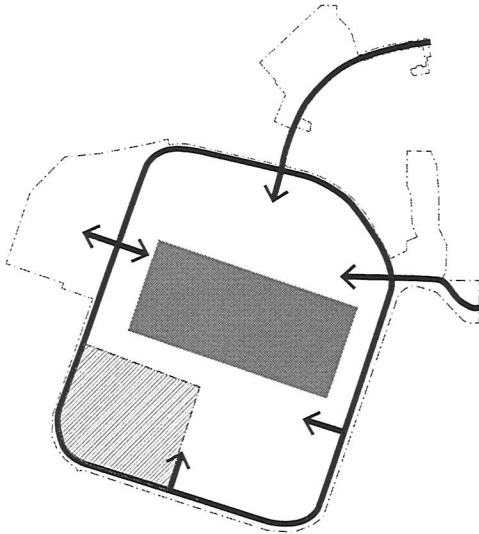

Concept 2 - Distributed

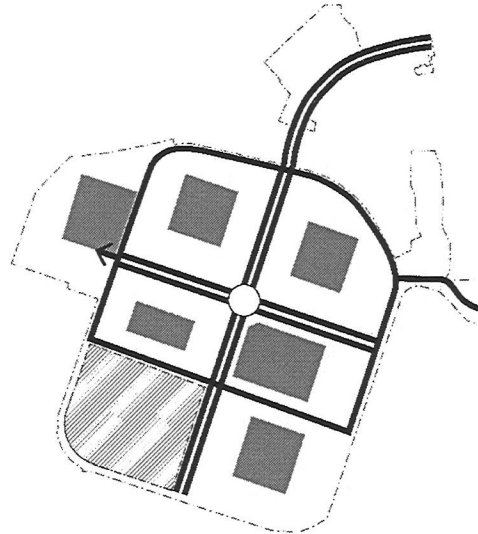

Concept 3 - Combination

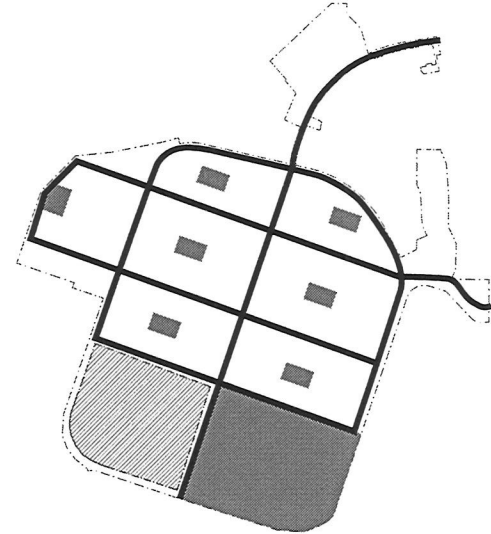

- Concept 1 – Consolidated
- Concept 2 – Distributed
- Concept 3 – Combination



Tell us more about you! What is your affiliation with Costa Mesa?

- I'm a resident
- I'm with an NGO/Non-Profit
- I'm a business owner
- I'm a developer
- I'm a property owner
- Other

*Costa
Mesa*

For active open space areas, what types of facilities do you prefer? (Choose 2)

- Soccer fields
- Baseball fields
- Playgrounds
- Recreation Center
- Trails

What alternative modes of transportation do you prefer? (Choose 2)

- Walking
- Biking
- Golf Cart (or Neighborhood Electric Vehicle)
- Scooter
- Transit

Of the three images, which circulation concept do you prefer? (Choose 1)

Concept 1 - Loop

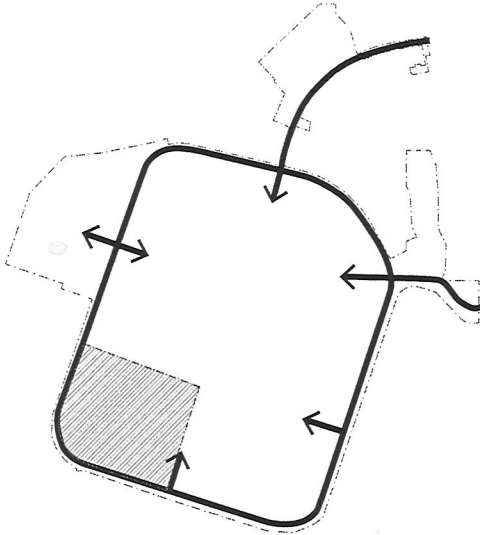

Concept 2 - Boulevard

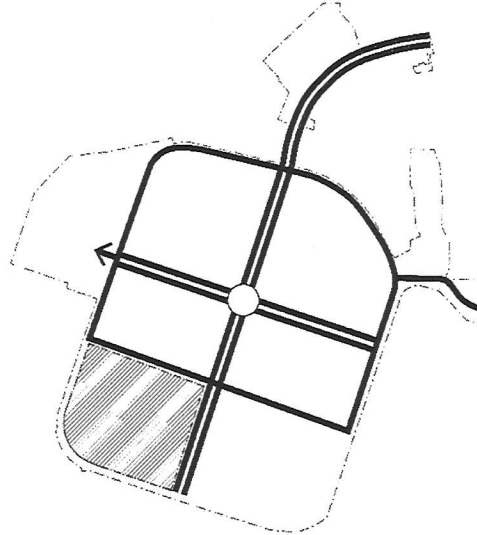

Concept 3 - Grid

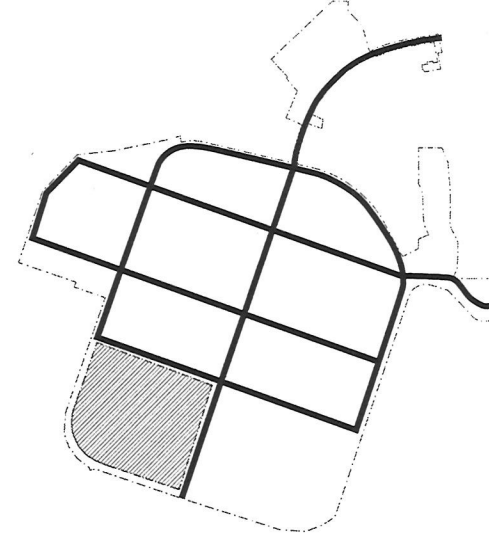

- Concept 1 – Loop
- Concept 2 – Boulevard
- Concept 3 – Grid

Of the three images, which park/open space configuration do you prefer? (Choose 1)

Concept 1 - Consolidated

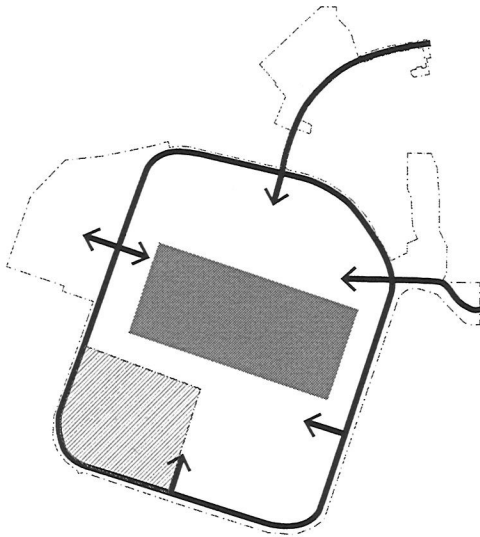

Concept 2 - Distributed

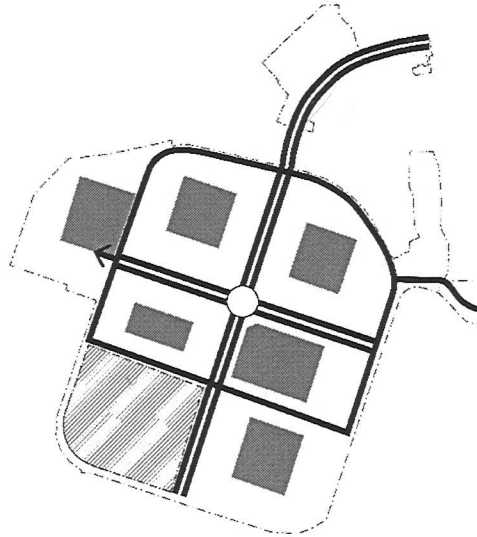

Concept 3 - Combination

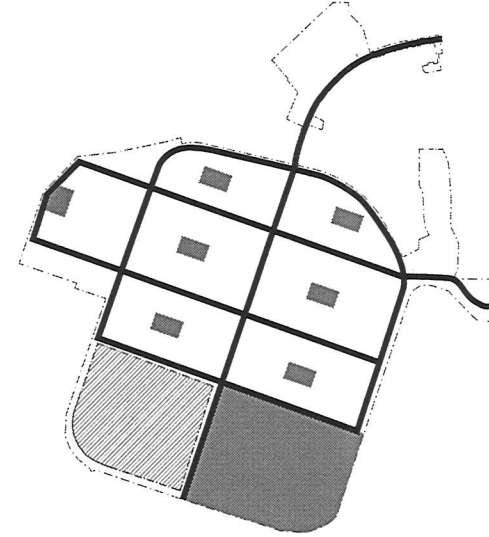

- Concept 1 – Consolidated
- Concept 2 – Distributed
- Concept 3 – Combination



Tell us more about you! What is your affiliation with Costa Mesa?

- I'm a resident
- I'm with an NGO/Non-Profit
- I'm a business owner
- I'm a developer
- I'm a property owner
- Other

For active open space areas, what types of facilities do you prefer? (Choose 2)

- Soccer fields
- Baseball fields
- Playgrounds
- Recreation Center
- Trails

What alternative modes of transportation do you prefer? (Choose 2)

- Walking
- Biking
- Golf Cart (or Neighborhood Electric Vehicle)
- Scooter
- Transit

Of the three images, which circulation concept do you prefer? (Choose 1)

Concept 3

Concept 1 - Loop

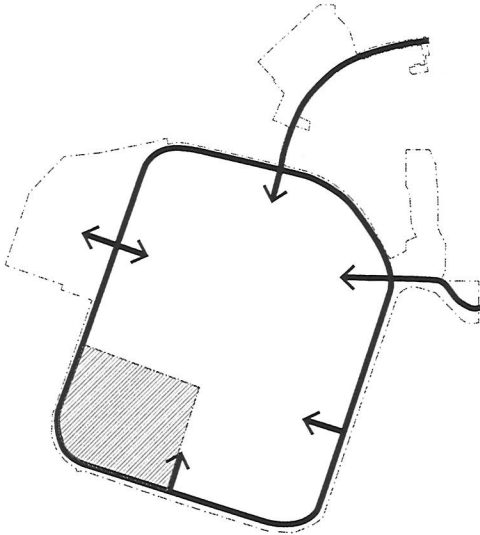

Concept 2 - Boulevard

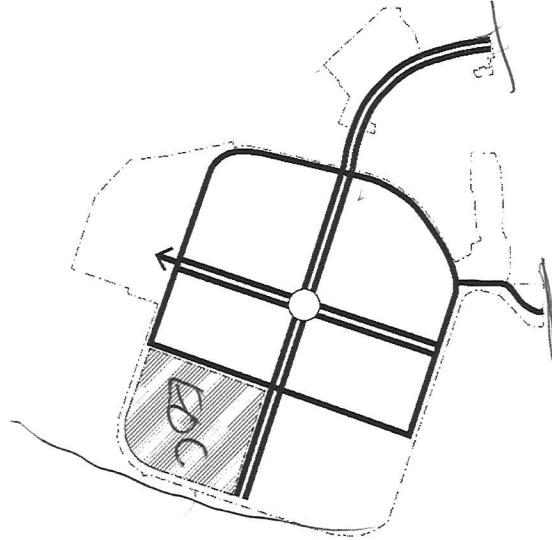

Concept 3 - Grid

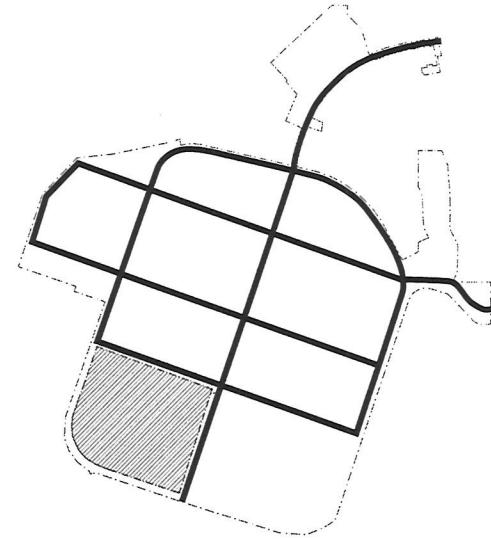

- Concept 1 – Loop
- Concept 2 – Boulevard
- Concept 3 – Grid

Of the three images, which park/open space configuration do you prefer? (Choose 1)

Concept 1 - Consolidated

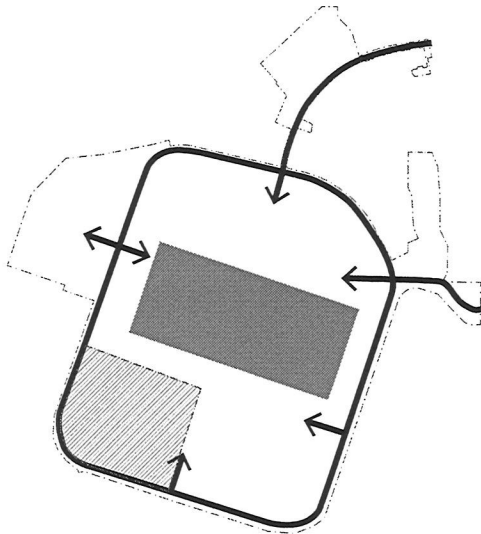

Concept 2 - Distributed

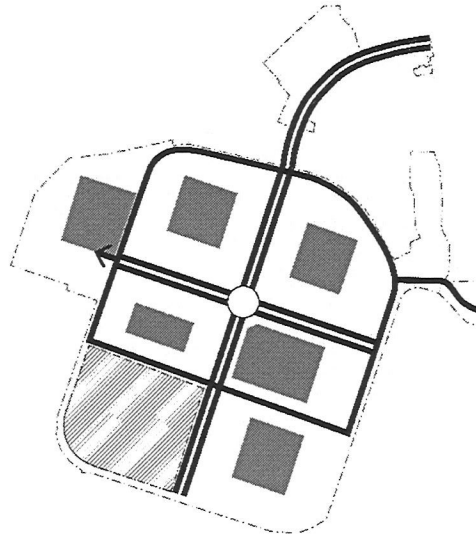

Concept 3 - Combination

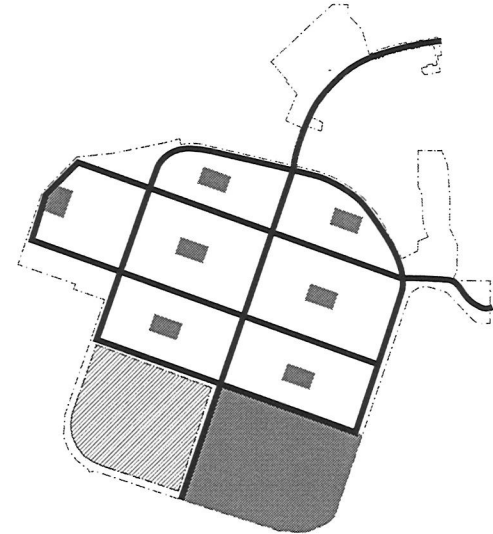

- Concept 1 – Consolidated
- Concept 2 – Distributed
- Concept 3 – Combination



Tell us more about you! What is your affiliation with Costa Mesa?

- I'm a resident
- I'm with an NGO/Non-Profit
- I'm a business owner
- I'm a developer
- I'm a property owner
- Other

For active open space areas, what types of facilities do you prefer? (Choose 2)

- Soccer fields
- Baseball fields
- Playgrounds
- Recreation Center
- Trails

What alternative modes of transportation do you prefer? (Choose 2)

- Walking
- Biking
- Golf Cart (or Neighborhood Electric Vehicle)
- Scooter
- Transit

Of the three images, which circulation concept do you prefer? (Choose 1)

Concept 1 - Loop

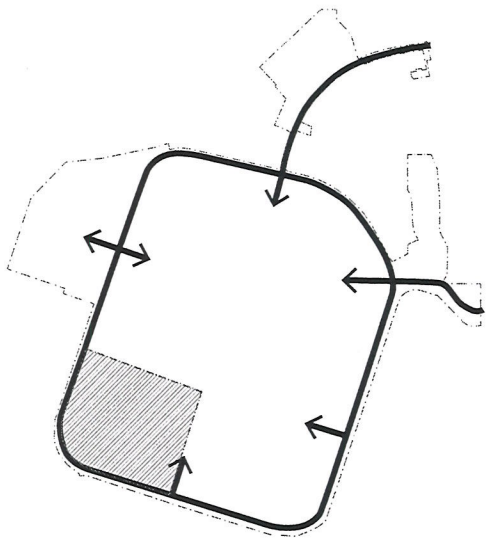

Concept 2 - Boulevard

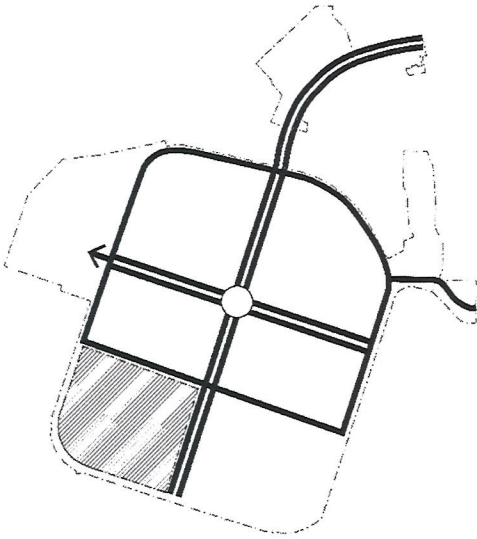

Concept 3 - Grid

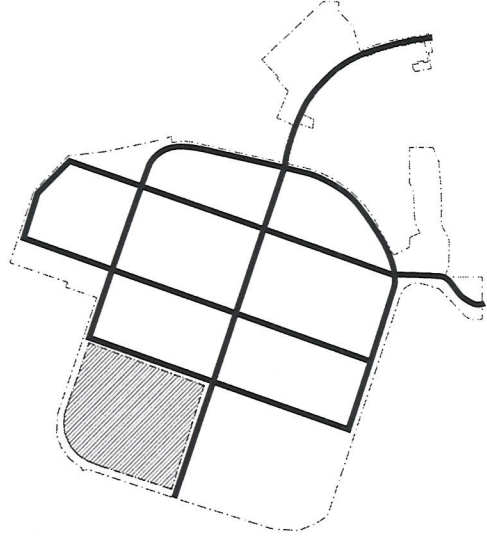

- Concept 1 – Loop
- Concept 2 – Boulevard
- Concept 3 – Grid

Of the three images, which park/open space configuration do you prefer? (Choose 1)

Concept 1 - Consolidated

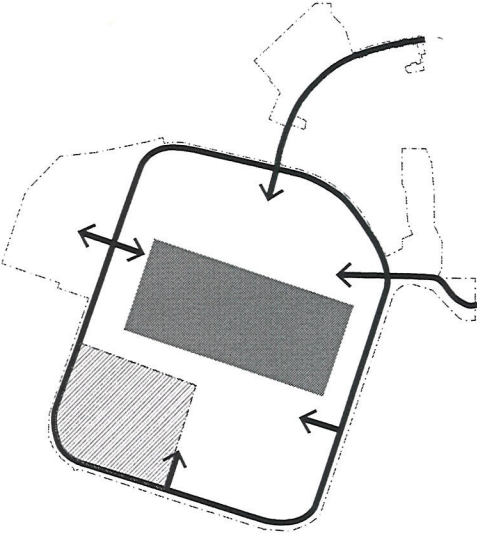

Concept 2 - Distributed

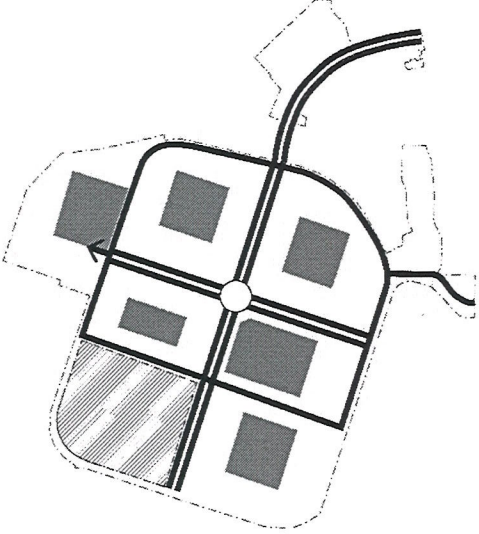

Concept 3 - Combination

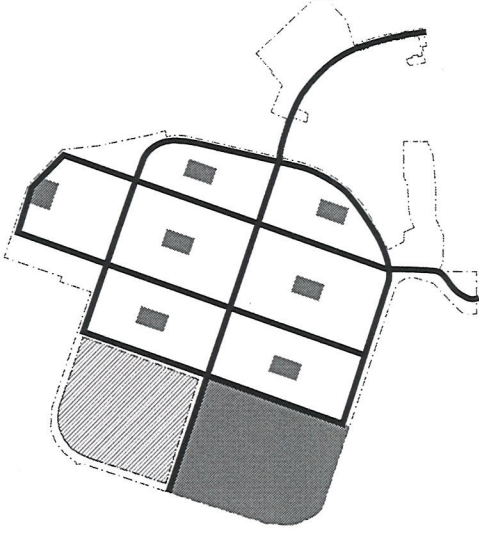

- Concept 1 – Consolidated
- Concept 2 – Distributed
- Concept 3 – Combination



Tell us more about you! What is your affiliation with Costa Mesa?

- I'm a resident
- I'm with an NGO/Non-Profit
- I'm a business owner
- I'm a developer
- I'm a property owner
- Other

For active open space areas, what types of facilities do you prefer? (Choose 2)

- Soccer fields
- Baseball fields
- Playgrounds
- Recreation Center
- Trails

why not just have a large open field that has a dedicated area for playground apparatus / rest rooms and rest

What alternative modes of transportation do you prefer? (Choose 2)

- Walking
- Biking
- Golf Cart (or Neighborhood Electric Vehicle)
- Scooter
- Transit

is open field for heavy use sports / picnic / etc

Of the three images, which circulation concept do you prefer? (Choose 1)

Concept 1 - Loop

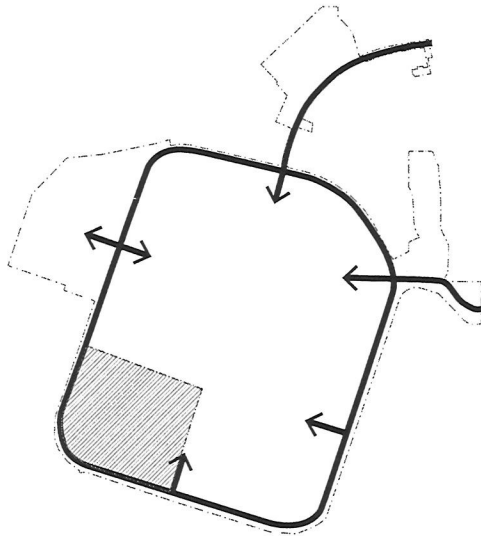

Concept 2 - Boulevard

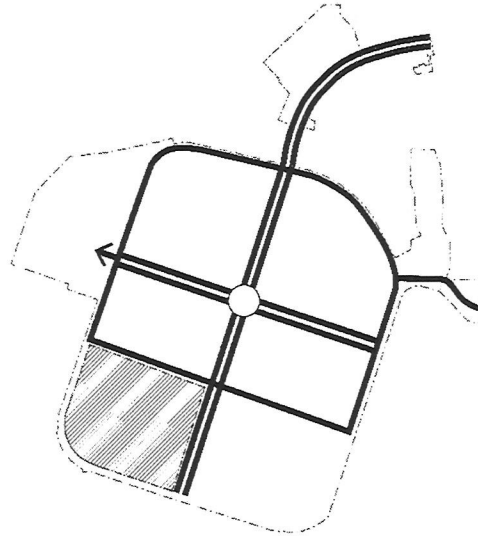

Concept 3 - Grid

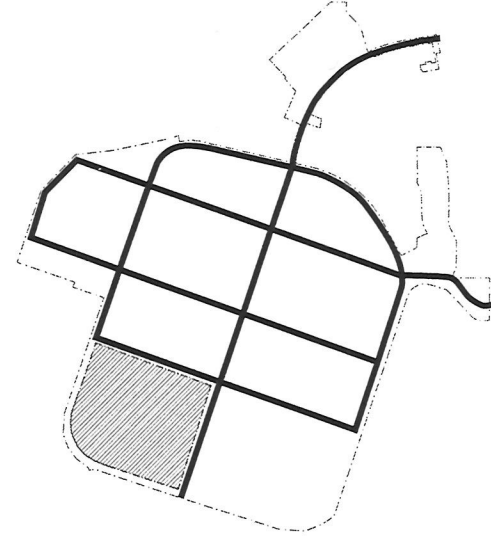

- Concept 1 – Loop
- Concept 2 – Boulevard
- Concept 3 – Grid

Of the three images, which park/open space configuration do you prefer? (Choose 1)

Concept 1 - Consolidated

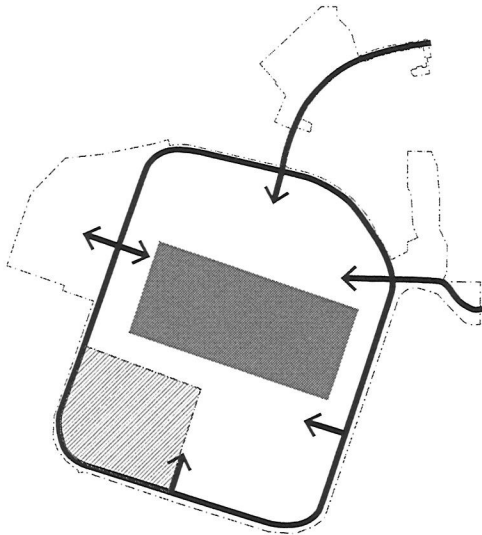

Concept 2 - Distributed

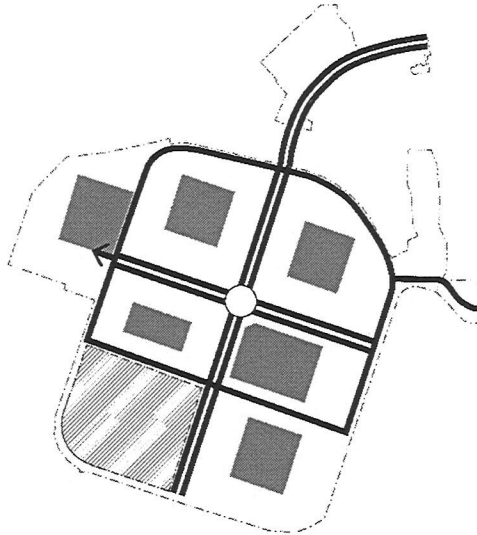

Concept 3 - Combination

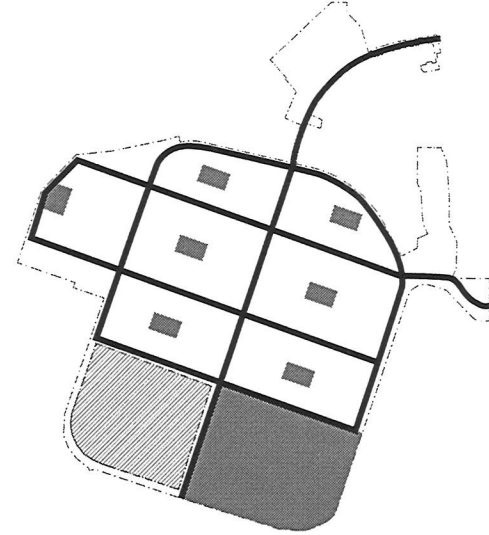

- Concept 1 – Consolidated
- Concept 2 – Distributed
- Concept 3 – Combination



Tell us more about you! What is your affiliation with Costa Mesa?

- I'm a resident
- I'm with an NGO/Non-Profit
- I'm a business owner
- I'm a developer
- I'm a property owner
- Other

For active open space areas, what types of facilities do you prefer? (Choose 2)

- Soccer fields
- Baseball fields
- Playgrounds
- Recreation Center
- Trails

What alternative modes of transportation do you prefer? (Choose 2)

- Walking
- Biking
- Golf Cart (or Neighborhood Electric Vehicle)
- Scooter
- Transit

Of the three images, which circulation concept do you prefer? (Choose 1)

Concept 1 - Loop

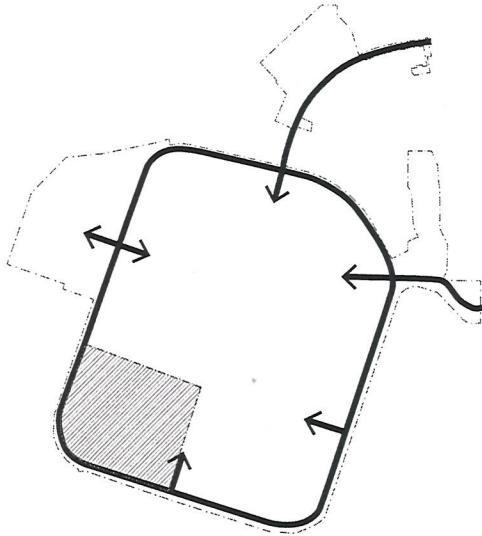

Concept 2 - Boulevard

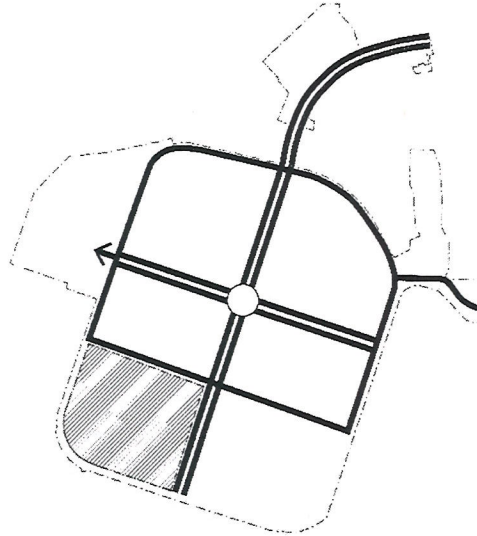

Concept 3 - Grid

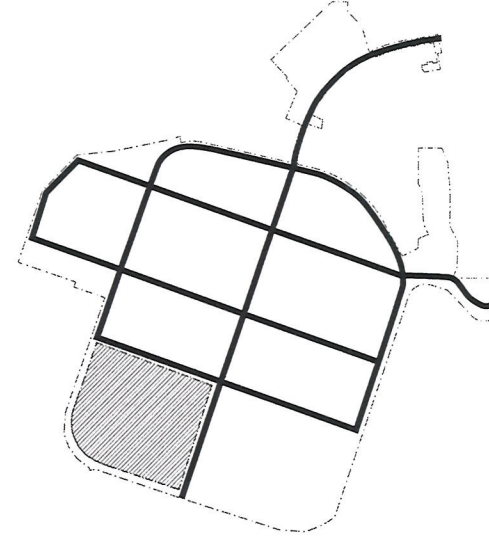

- Concept 1 – Loop
- Concept 2 – Boulevard
- Concept 3 – Grid

Of the three images, which park/open space configuration do you prefer? (Choose 1)

Concept 1 - Consolidated

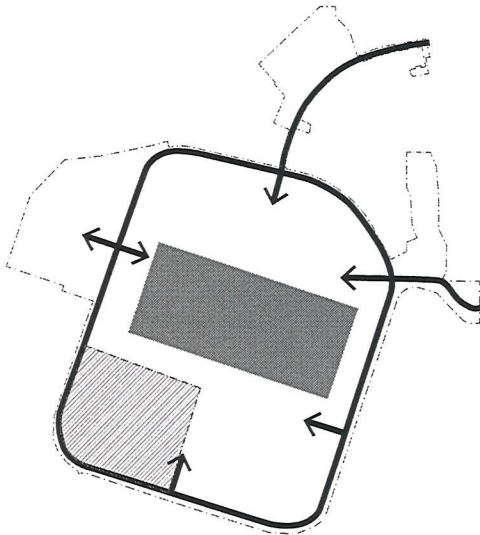

Concept 2 - Distributed

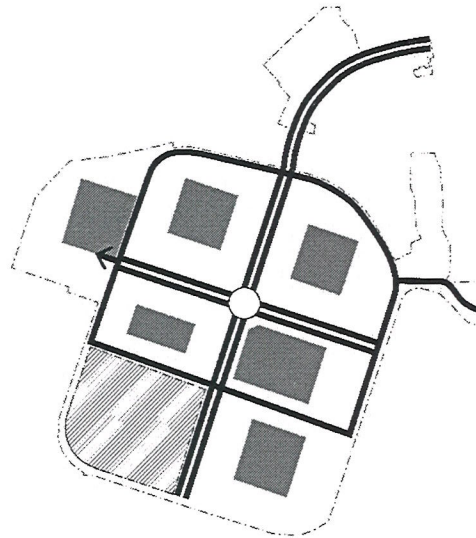

Concept 3 - Combination

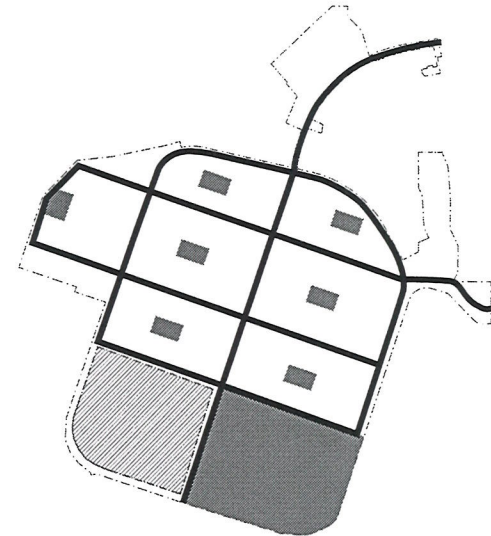

- Concept 1 – Consolidated
- Concept 2 – Distributed
- Concept 3 – Combination